

CALENDAR FOR THE BOARD OF SUPERVISORS  
**CONTRA COSTA COUNTY**  
AND FOR SPECIAL DISTRICTS, AGENCIES, AND AUTHORITIES GOVERNED BY THE BOARD  
**BOARD CHAMBERS ROOM 107, ADMINISTRATION BUILDING, 651 PINE STREET**  
**MARTINEZ, CALIFORNIA 94553-1229**

CANDACE ANDERSEN, *CHAIR*, 2ND DISTRICT  
MARY N. PIEPHO, *VICE CHAIR*, 3RD DISTRICT  
JOHN GIOIA, 1ST DISTRICT  
KAREN MITCHOFF, 4TH DISTRICT  
FEDERAL D. GLOVER, 5TH DISTRICT

DAVID J. TWA, CLERK OF THE BOARD AND COUNTY ADMINISTRATOR, (925) 335-1900

PERSONS WHO WISH TO ADDRESS THE BOARD DURING PUBLIC COMMENT OR WITH RESPECT TO AN ITEM THAT IS ON THE AGENDA,  
MAY BE LIMITED TO TWO (2) MINUTES.  
A LUNCH BREAK MAY BE CALLED AT THE DISCRETION OF THE BOARD CHAIR.

The Board of Supervisors respects your time, and every attempt is made to accurately estimate when an item may be heard by the Board. All times specified for items on the Board of Supervisors agenda are approximate. Items may be heard later than indicated depending on the business of the day. Your patience is appreciated.

**ANNOTATED AGENDA and MINUTES**  
**November 1, 2016**

**9:00 A.M. Convene and call to order and opening ceremonies.**

Inspirational Thought "Curiosity is natural to the soul of man and interesting objects have a powerful influence on our affections." ~ Daniel Boone

Present: District I Supervisor John Gioia; District II Supervisor Candace Andersen; District III Supervisor Mary N. Piepho; District IV Supervisor Karen Mitchoff; District V Supervisor Federal D. Glover

Staff Present: David Twa, County Administrator

**CONSIDER CONSENT ITEMS** (Items listed as C.1 through C.56 on the following agenda) – Items are subject to removal from Consent Calendar by request of any Supervisor or on request for discussion by a member of the public. **Items removed from the Consent Calendar will be considered with the Discussion Items.**

**PRESENTATIONS (5 Minutes Each)**

PRESENTATION honoring the Contra Costa Chorale on its 50th Anniversary of providing musical excellence by and for the community. (Supervisor Gioia)

AYE: District I Supervisor John Gioia, District II Supervisor Candace Andersen, District III Supervisor Mary N. Piepho, District IV Supervisor Karen Mitchoff, District V Supervisor Federal D. Glover

PRESENTATION proclaiming November 2, 2016 as the Contra Costa County Shelter-in-Place Education Day. (William Walker, M.D., Health Services Director)

AYE: District I Supervisor John Gioia, District II Supervisor Candace Andersen, District III Supervisor Mary N. Piepho, District IV Supervisor Karen Mitchoff, District V Supervisor Federal D. Glover

PRESENTATION proclaiming November 2016 as Adoption Awareness Month in Contra Costa County. (Kathy Gallagher, Employment and Human Services Director)

AYE: District I Supervisor John Gioia, District II Supervisor Candace Andersen, District III Supervisor Mary N. Piepho, District IV Supervisor Karen Mitchoff, District V Supervisor Federal D. Glover

**PR.4** PRESENTATION recognizing November 2016 as Homeless Awareness Month in Contra Costa County. (Lavonna Martin, Director - Health, Housing, and Homeless Services)

AYE: District I Supervisor John Gioia, District II Supervisor Candace Andersen, District III Supervisor Mary N. Piepho, District IV Supervisor Karen Mitchoff, District V Supervisor Federal D. Glover

## **DISCUSSION ITEMS**

**D. 1** CONSIDER Consent Items previously removed.

*Consent item C.26 was removed to allow for comment from the public, and was RELISTED to be considered on November 15, 2016.*

**D. 2** PUBLIC COMMENT (2 Minutes/Speaker)

*Gregory Osorio, resident of Pittsburg, spoke in support of Supervisor Glover;  
Rick Marazzani, resident of Martinez, spoke on how the Section 8 program provides for the needs of the elderly, disabled, and veterans and expressed dismay that in the election cycle the program is being used in a disparaging way against a candidate for office;  
Victoria Adams, resident of Pittsburg; spoke in support of Supervisor Glover, recounting some public improvements he brought to East County;  
Charles Davidson, resident of Hercules (handout attached); expressed disapproval of a political mailing by an independent expenditure committee, that he believes acted without the support of officials running for office;  
Douglas Van Raam, The Hemp Church, Teach Hemp Committee, expressed his objection that elected officials would not support his usage of cannabis while having an arrest record of their own, and that he supports Anamarie Avila Farias for office.*

**D.3** CONSIDER accepting the 2016 Other Post Employment Benefits Valuation Report as of January 1, 2016 including Annual Required Contributions for the Fiscal Year Ending June 30, 2016. (Lisa Driscoll, County Finance Director)

AYE: District I Supervisor John Gioia, District II Supervisor Candace Andersen, District III Supervisor Mary N. Piepho, District IV Supervisor Karen Mitchoff, District V Supervisor Federal D. Glover

**D.4** CONSIDER adopting proposed health plan changes for specified retirees who retired on or after January 1, 2016 or opted out of Retiree Support Group Settlement (David Twa, County Administrator)

AYE: District I Supervisor John Gioia, District II Supervisor Candace Andersen, District III Supervisor Mary N. Piepho, District IV Supervisor Karen Mitchoff, District V Supervisor Federal D. Glover

9:30 A.M.

- D.5** Acting in its capacity as the Contra Costa County Board of Supervisors and as the Board of Directors of the Crockett-Carquinez Fire Protection District and the Contra Costa County Fire Protection District, HEARING on the adoption of Ordinance No. 2016-23, which adopts the 2016 California Fire Code with local amendments. (Robert Marshall, Fire Marshal)

***CLOSED the public hearing; ADOPTED Ordinance No. 2016-23, adopting the 2016 California Fire Code, with local amendments, as the fire code within Contra Costa County, the Contra Costa County Fire Protection District, and the Crockett-Carquinez Fire Protection District;***

***ADOPTED findings in support of the amendments to the 2016 California Fire Code;***

***DIRECTED the Fire Districts, pursuant to Health and Safety Code section 17958.7, to send a certified copy of Ordinance No. 2016-23, the attached findings, and this Board Order to the California Department of Housing and Community Development and to the California Building Standards Commission.***

***AUTHORIZED the publication of the ordinance summary prepared by County Counsel in accordance with Government Code section 25124;***

***DIRECTED the Clerk of the Board of Supervisors to post at its office, and each Fire District to post at its office, a certified copy of the full text of Ordinance No. 2016-23, as adopted, with the names of the Supervisors/Directors voting for and against the ordinance, in accordance with Government Code section 25124;***

***FOUND that adoption of the ordinance is exempt from CEQA pursuant to CEQA guidelines section 15061(b)(3);***

***and DIRECTED staff to file a Notice of Exemption with the County Clerk.***

AYE: District I Supervisor John Gioia, District II Supervisor Candace Andersen, District III Supervisor Mary N. Piepho, District IV Supervisor Karen Mitchoff, District V Supervisor Federal D. Glover

- D.6** HEARING to consider County Planning Commission recommendations to accept the permit review report pertaining to the Keller Canyon Landfill land use permit. (100% Applicant/Landfill operator fees) (David Brockbank, Conservation and Development Department)

Speakers: Don E. Garcia, Teamsters 315; Lisa Della Rocca, resident of Pittsburg (handout attached); Laura Wright, City of Pittsburg; EVan xxxxx; Dana Dean, representing Evan Edgar and Monica White; Greg Osorio, Garrett Evans;

***CLOSED the public hearing; ACCEPTED the permit review report pertaining to the Keller Canyon Landfill land use permit conditions of approval, which concludes that there is no need to add or modify the existing permit conditions; and DIRECTED Department of Conservation and Development staff to schedule the third annual permit review for consideration by the County Planning Commission in October 2017, in accordance with Condition 11.1 of the existing Keller Canyon Landfill land use permit.***

- D.7** HEARING on the itemized costs of abatement for real property located at 425 Market Ave., Richmond, California (Fred Urquhart II, owner). (Jason Crapo, Conservation and Development Department)

*CLOSED the hearing; DETERMINED the cost of all abatement work and all administrative costs to be \$21,616.58; ORDERED the itemized report confirmed and DIRECTED that it be filed with the Clerk of the Board of Supervisors; ORDERED the costs to be specially assessed against the property and AUTHORIZED the recordation of a Notice of Abatement Lien.*

**D.8** CONSIDER approving the Contra Costa County Parklet Program, to govern the establishment of parklets as encroachments within County rights of way countywide, as recommended by the Public Works Director. (100% Applicant Fees) (Mary Halle, Public Works Department)

AYE: District I Supervisor John Gioia, District II Supervisor Candace Andersen, District III Supervisor Mary N. Piepho, District IV Supervisor Karen Mitchoff, District V Supervisor Federal D. Glover

D. 9 CONSIDER reports of Board members.

*Supervisor Piepho attended the October 2016 annual conference of the CALAFCO in Santa Barbara. She announced that Contra Costa County tied for third place with Napa County in the annual wine competition with the Tamayo Vineyards Sirah . She has informed the Contra Costa Wine Association. (<http://calafco.org/>)*

*Supervisor Mitchoff encouraged the other Supervisors to consider attending the Bay Area Confluence event convened by the Association of Bay Area Governments (ABAG) on November 10 2016 at the Oakland Museum of California to address regional water resilience. ([http://www.abag.ca.gov/resilience/bay\\_area\\_confluence\\_2016.html](http://www.abag.ca.gov/resilience/bay_area_confluence_2016.html))*

#### **Closed Session**

#### **A. CONFERENCE WITH LABOR NEGOTIATORS**

1. Agency Negotiators: David Twa and Bruce Heid.

Employee Organizations: Contra Costa County Employees' Assn., Local No. 1; Am. Fed., State, County, & Mun. Empl., Locals 512 and 2700; Calif. Nurses Assn.; Service Empl. Int'l Union, Local1021; District Attorney's Investigators Assn.; Deputy Sheriffs Assn.; United Prof. Firefighters, Local 1230; Physicians' & Dentists' Org. of Contra Costa; Western Council of Engineers; United Chief Officers Assn.; Service Empl. Int'l Union United Health Care Workers West; Contra Costa County Defenders Assn.; Probation Peace Officers Assn. of Contra Costa County; Contra Costa County Deputy District Attorneys' Assn.; and Prof. & Tech. Engineers, Local 21, AFL-CIO; Teamsters Local 856.

2. Agency Negotiators: David Twa.

Unrepresented Employees: All unrepresented employees.

#### **B. CONFERENCE WITH LEGAL COUNSEL--EXISTING LITIGATION** (Gov. Code, § 54956.9(d)(1))

1. *Retiree Support Group of Contra Costa County v. Contra Costa County*, U.S. District Court, Northern District of California, Case No. C12-00944 JST

#### **C. CONFERENCE WITH LEGAL COUNSEL--ANTICIPATED LITIGATION**

Significant exposure to litigation pursuant to Gov. Code, § 54956.9(d)(2): One potential case

*There were no reports from Closed Session.*

**ADJOURN**

**CONSENT ITEMS**

**Engineering Services**

- C. 1** ADOPT Resolution No. 2016/601 approving and authorizing the Public Works Director, or designee, to fully close the north bound lanes of Danville Boulevard between Orchard Lane and Jackson Way, and to fully close Jackson Way at the intersection with Danville Boulevard, on December 4, 2016 from 4:30 p.m. to 6:30 p.m., for the purpose of the Annual Alamo Tree Lighting Event, Alamo area. (No fiscal impact)

AYE: District I Supervisor John Gioia, District II Supervisor Candace Andersen, District III Supervisor Mary N. Piepho, District IV Supervisor Karen Mitchoff, District V Supervisor Federal D. Glover

**Special Districts & County Airports**

- C. 2** APPROVE and AUTHORIZE the Auditor-Controller, or designee, to issue a payment on behalf of the Public Works Director, in the amount of \$1,500, from County Service Area R-7A, payable to the Community Foundation of Alamo for the holiday lights at Andrew H. Young Park, Alamo Area. (100% County Services Area R-7A Funds)

AYE: District I Supervisor John Gioia, District II Supervisor Candace Andersen, District III Supervisor Mary N. Piepho, District IV Supervisor Karen Mitchoff, District V Supervisor Federal D. Glover

**Claims, Collections & Litigation**

- C. 3** DENY claims filed by Clark Pest Control, David Hofman, Jason Hunt, Seth Krubiner, Eugene Mangini, Howard Perdue, Denise Smullen, State Farm Insurance for Pierin Daberdaku Claim and Dillon Vassey, a minor.

AYE: District I Supervisor John Gioia, District III Supervisor Mary N. Piepho, District IV Supervisor Karen Mitchoff, District V Supervisor Federal D. Glover

Other: District II Supervisor Candace Andersen (RECUSE)

**Honors & Proclamations**

- C. 4** ADOPT Resolution No. 2016/631 recognizing Karen Shuler for her years of service to the Behavioral Health Division of Health Services and the Mental Health Commission, as recommended by the Health Services Director.

AYE: District I Supervisor John Gioia, District II Supervisor Candace Andersen, District III Supervisor Mary N. Piepho, District IV Supervisor Karen Mitchoff, District V Supervisor Federal D. Glover

- C. 5** ADOPT Resolution No. 2016/567 recognizing Mary Whatford upon her retirement as Recorder Operations Manager in the County Clerk-Recorder Department, as recommended by the Clerk-Recorder.

AYE: District I Supervisor John Gioia, District II Supervisor Candace Andersen, District III Supervisor Mary N. Piepho, District IV Supervisor Karen Mitchoff, District V Supervisor Federal D. Glover

- C. 6** ADOPT Resolution No. 2016/578 honoring the Contra Costa Chorale on its 50th Anniversary of providing musical excellence by and for the community, as recommended by Supervisor Gioia.

AYE: District I Supervisor John Gioia, District II Supervisor Candace Andersen, District III Supervisor Mary N. Piepho, District IV Supervisor Karen Mitchoff, District V Supervisor Federal D. Glover

- C. 7** ADOPT Resolution No. 2016/605 honoring Easter Hill United Methodist Church of Richmond, California on its 65th Anniversary, as recommended by Supervisor Gioia.

AYE: District I Supervisor John Gioia, District II Supervisor Candace Andersen, District III Supervisor Mary N. Piepho, District IV Supervisor Karen Mitchoff, District V Supervisor Federal D. Glover

- C. 8** ADOPT Resolution No. 2016/607 proclaiming November 2016 as Adoption Awareness Month in Contra Costa County, as recommended by the Employment and Human Services Director.

AYE: District I Supervisor John Gioia, District II Supervisor Candace Andersen, District III Supervisor Mary N. Piepho, District IV Supervisor Karen Mitchoff, District V Supervisor Federal D. Glover

- C. 9** ADOPT Resolution No. 2016/617 proclaiming November 2, 2016 as the Contra Costa County Shelter-in-Place Education Day, as recommended by the Health Services Director.

AYE: District I Supervisor John Gioia, District II Supervisor Candace Andersen, District III Supervisor Mary N. Piepho, District IV Supervisor Karen Mitchoff, District V Supervisor Federal D. Glover

### **Ordinances**

- C. 10** ADOPT Ordinance No. 2016-20 amending the County Ordinance Code to change the appointing authority of the exempt classification of Medical Director and to remove the exempt classifications of Ambulatory Care Chief Executive Officer, Contra Costa Health Plan Medical Director, and Mental Health Medical Director from the list of classifications excluded from the Merit System, as requested by the Health Services Department. (No cost)

AYE: District I Supervisor John Gioia, District II Supervisor Candace Andersen, District III Supervisor Mary N. Piepho, District IV Supervisor Karen Mitchoff, District V Supervisor Federal D. Glover

### **Appointments & Resignations**

- C. 11** APPROVE the medical staff appointments and reappointments, additional privileges, department change request, medical staff advancement and application withdrawal as recommend by the Medical Staff Executive Committee, at their October 18, 2016 meeting, and by the Health Services Director.

AYE: District I Supervisor John Gioia, District II Supervisor Candace Andersen, District III Supervisor Mary N. Piepho, District IV Supervisor Karen Mitchoff, District V Supervisor Federal D. Glover

### **Personnel Actions**

- C. 12** ADOPT Position Adjustment Resolution No. 21986 to reallocate the salary of the Mental Health Clinical Specialist - Project (represented) classification on the salary schedule in the Health Services Department. (100% General Fund)

AYE: District I Supervisor John Gioia, District II Supervisor Candace Andersen, District III Supervisor Mary N. Piepho, District IV Supervisor Karen Mitchoff, District V Supervisor Federal D. Glover

- C. 13** ADOPT Position Adjustment Resolution No. 21979 to abolish the classifications of CCHP Medical Director-Exempt, Mental Health Medical Director-Exempt, and Ambulatory Care Chief Executive Officer-Exempt, cancel three vacant positions, and add two Medical Director-Exempt positions in the Health Services Department. (100% Contra Costa Health Plan Enterprise Fund II)

AYE: District I Supervisor John Gioia, District II Supervisor Candace Andersen, District III Supervisor Mary N. Piepho, District IV Supervisor Karen Mitchoff, District V Supervisor Federal D. Glover

- C. 14** ADOPT Position Adjustment Resolution No. 21970 to add one Administrative Aide-Deep Class (unrepresented) position in the Library Department. (100% Library Fund)

AYE: District I Supervisor John Gioia, District II Supervisor Candace Andersen, District III Supervisor Mary N. Piepho, District IV Supervisor Karen Mitchoff, District V Supervisor Federal D. Glover

- C. 15** ADOPT Position Adjustment Resolution No. 21984 to add two permanent intermittent Junior Radiological Technologist positions (represented) and two permanent intermittent Senior Radiological Technologist positions (represented) in the Health Services Department. (100% Hospital Enterprise Fund I)

AYE: District I Supervisor John Gioia, District II Supervisor Candace Andersen, District III Supervisor Mary N. Piepho, District IV Supervisor Karen Mitchoff, District V Supervisor Federal D. Glover

- C. 16** ADOPT Position Adjustment Resolution No. 21985 to add 41 represented permanent positions in various classifications in the Health Services Department. (100% Whole Person Care Pilot Program revenues)

AYE: District I Supervisor John Gioia, District II Supervisor Candace Andersen, District III Supervisor Mary N. Piepho, District IV Supervisor Karen Mitchoff, District V Supervisor Federal D. Glover

### **Grants & Contracts**

**APPROVE and AUTHORIZE execution of agreements between the County and the following agencies for receipt of fund and/or services:**

- C. 17** APPROVE and AUTHORIZE the County Librarian, or designee, to accept a restricted donation in an estimated amount of \$80,000 from the James S. DeLoach Trust, for the exclusive use in support of the El Cerrito Library. (No Library Fund match)

AYE: District I Supervisor John Gioia, District II Supervisor Candace Andersen, District III Supervisor Mary N. Piepho, District IV Supervisor Karen Mitchoff, District V Supervisor Federal D. Glover

- C. 18** APPROVE and AUTHORIZE the County Librarian, or designee, to accept a restricted donation in an estimated amount of \$100,000 from the Eugene S. Troy Trust, for the exclusive use in support of the El Cerrito Library. (No Library Fund match)

AYE: District I Supervisor John Gioia, District II Supervisor Candace Andersen, District III Supervisor Mary N. Piepho, District IV Supervisor Karen Mitchoff, District V Supervisor Federal D. Glover

- C. 19** ADOPT Resolution No. 2016/600 to approve and authorize the Employment and Human Services Director, or designee, to execute a contract amendment with California Department of Aging, effective September 30, 2016, to increase the payment limit to the County by \$344,004 to a new payment limit of \$4,302,156, with no change in the term July 1, 2016 through June 30, 2017, for Older Americans Act services to low-income older County residents. (No additional County match)

AYE: District I Supervisor John Gioia, District II Supervisor Candace Andersen, District III Supervisor Mary N. Piepho, District IV Supervisor Karen Mitchoff, District V Supervisor Federal D. Glover

- C. 20** APPROVE and AUTHORIZE the Health Services Director, or designee, to execute a contract with the Department of Health Care Services, Children Medical Services, to pay the County an amount not to exceed \$1,929,816 for the Child Health and Disability Prevention and the Health Care Program for Children in Foster Care programs, for the period July 1, 2016 through June 30, 2017. (County match: \$411,459, budgeted)

AYE: District I Supervisor John Gioia, District II Supervisor Candace Andersen, District III Supervisor Mary N. Piepho, District IV Supervisor Karen Mitchoff, District V Supervisor Federal D. Glover

- C. 21** APPROVE and AUTHORIZE the Health Services Director, or designee, to execute a contract with the City of Antioch for its Community Development Department Block Grant funding, to pay the County an amount not to exceed \$10,000 for continuation of the operation of the Adult Interim Housing Program, for the period July 1, 2016 through June 30, 2017. (No County match)

AYE: District I Supervisor John Gioia, District II Supervisor Candace Andersen, District III Supervisor Mary N. Piepho, District IV Supervisor Karen Mitchoff, District V Supervisor Federal D. Glover

- C. 22** APPROVE and AUTHORIZE the Health Services Director, or designee, to execute a contract amendment with the County of Alameda Health Care Services Agency, effective March 1, 2016, to increase the total payment to County by \$160,108 to a new payment limit of \$1,557,894, with no change in the original term of March 1, 2016 through February 28, 2017, for additional coordination of essential services to Contra Costa County residents with HIV Disease and their families. (No County match)

AYE: District I Supervisor John Gioia, District II Supervisor Candace Andersen, District III Supervisor Mary N. Piepho, District IV Supervisor Karen Mitchoff, District V Supervisor Federal D. Glover



- C. 23** APPROVE and AUTHORIZE the Chair of the Board of Supervisors to execute the First Amendment to the County Franchise Agreement with Crockett Garbage Company to extend the term of the Agreement through December 31, 2016, as recommended by the Conservation and Development Director. (100% Solid Waste/Recycling Franchise fees)

AYE: District I Supervisor John Gioia, District II Supervisor Candace Andersen, District III Supervisor Mary N. Piepho, District IV Supervisor Karen Mitchoff, District V Supervisor Federal D. Glover

- C. 24** APPROVE and AUTHORIZE the Health Services Director, or designee, to execute a contract with Public Health Foundation Enterprises, Inc., to pay County an amount not to exceed \$92,874 to support the Centers for Disease Control and Prevention's (CDC) Emerging Infections Program - Retail Foods Project for the period September 1, 2016 through August 31, 2017. (No County match)

AYE: District I Supervisor John Gioia, District II Supervisor Candace Andersen, District III Supervisor Mary N. Piepho, District IV Supervisor Karen Mitchoff, District V Supervisor Federal D. Glover

**APPROVE and AUTHORIZE execution of agreement between the County and the following parties as noted for the purchase of equipment and/or services:**

- C. 25** APPROVE and AUTHORIZE the Conservation and Development Director, or designee, to execute a contract amendment with First Carbon Solutions, to increase the payment limit by \$71,385 to a new payment limit of \$404,424 with no change to the term of September 10, 2014 through September 9, 2018, for services required to prepare the Environmental Impact Report for the Tassajara Parks Project in the Tassajara Valley, San Ramon area. (100% Applicant fees)

AYE: District I Supervisor John Gioia, District II Supervisor Candace Andersen, District III Supervisor Mary N. Piepho, District IV Supervisor Karen Mitchoff, District V Supervisor Federal D. Glover

- C. 26** APPROVE and AUTHORIZE the Health Services Director, or designee, to execute a contract amendment with All Health Services Corporation, effective July 1, 2016, to increase the payment limit by \$2,389,412 to a new payment limit of \$4,356,412 to provide additional hours of temporary medical staffing services at Contra Costa Regional Medical Center and Health Centers, with no change in the original term of October 1, 2015 through September 30, 2017. (100% Hospital Enterprise Fund I)

***Speaker: Richard Andazola, Teamsters 856.  
RELISTED to November 15, 2016.***

- C. 27** APPROVE and AUTHORIZE the Conservation and Development Director, or designee, to execute a contract including modified indemnification language with NBS Government Finance Group in an amount not to exceed \$67,561 for financial consulting services, for the period November 1, 2016 through October 31, 2017. (100% Land Development Fees)

AYE: District I Supervisor John Gioia, District II Supervisor Candace Andersen, District III Supervisor Mary N. Piepho, District IV Supervisor Karen Mitchoff, District V Supervisor Federal D. Glover

- C. 28** APPROVE and AUTHORIZE the Conservation and Development Director, or designee, to execute a contract with Ten2Eleven Business Solutions in an amount not to exceed \$137,280 to advise the Conservation and Development and the Public Works departments on options to modernize the information technology system used by both departments to bill applicants for land development services provided by the two departments, for the period November 1, 2016 through October 31, 2017. (100% Land Development Fees)

AYE: District I Supervisor John Gioia, District II Supervisor Candace Andersen, District III Supervisor Mary N. Piepho, District IV Supervisor Karen Mitchoff, District V Supervisor Federal D. Glover

- C. 29** APPROVE and AUTHORIZE the Public Works Director, or designee, to execute a contract including modified indemnification language with PDM Group, Inc., in an amount not to exceed \$25,000 to provide County right of way services related to the City of Napa First and Second Street Roundabouts Project, for the period October 1, 2016 through September 30, 2017. (100% City of Napa funds)

AYE: District I Supervisor John Gioia, District II Supervisor Candace Andersen, District III Supervisor Mary N. Piepho, District IV Supervisor Karen Mitchoff, District V Supervisor Federal D. Glover

- C. 30** APPROVE and AUTHORIZE the Health Services Director, or designee, to execute a contract with United Family Care, LLC (dba Family Courtyard), in an amount not to exceed \$453,840 to provide augmented board and care services for the period December 1, 2016 through November 30, 2017. (100% Mental Health Realignment funds)

AYE: District I Supervisor John Gioia, District II Supervisor Candace Andersen, District III Supervisor Mary N. Piepho, District IV Supervisor Karen Mitchoff, District V Supervisor Federal D. Glover

- C. 31** APPROVE and AUTHORIZE the Health Services Director, or designee, to execute a contract with Telecare Corporation in an amount not to exceed \$1,352,909 to provide gero-psychiatric and subacute mental health care services to severely and persistently mentally ill clients, for the period July 1, 2016 through June 30, 2017. (76% Mental Health Realignment and 24% Hospital Utilization Review)

AYE: District I Supervisor John Gioia, District II Supervisor Candace Andersen, District III Supervisor Mary N. Piepho, District IV Supervisor Karen Mitchoff, District V Supervisor Federal D. Glover

- C. 32** APPROVE and AUTHORIZE the Purchasing Agent or designee to execute, on behalf of the Public Works Director, a purchase order amendment with Lehr Auto Electric, Inc., to extend the term from January 31, 2017 through January 31, 2018 and increase the payment limit by \$400,000 to a new payment limit of \$650,000 for emergency vehicle parts, accessories and fabrication, Countywide. (100% Internal Service Fund-Fleet)

AYE: District I Supervisor John Gioia, District II Supervisor Candace Andersen, District III Supervisor Mary N. Piepho, District IV Supervisor Karen Mitchoff, District V Supervisor Federal D. Glover

- C. 33** APPROVE and AUTHORIZE the Health Services Director, or designee, to execute a contract with the San Ramon Valley Fire Department in an amount not to exceed \$375,000 to coordinate the services of a Fire Services Emergency Medical Services Medical Director, for the period December 15, 2016 through December 14, 2019. (100% Measure H funds)

AYE: District I Supervisor John Gioia, District II Supervisor Candace Andersen, District III Supervisor Mary N. Piepho, District IV Supervisor Karen Mitchoff, District V Supervisor Federal D. Glover

- C. 34** APPROVE and AUTHORIZE the Health Services Director, or designee, to execute a contract with the San Ramon Valley Fire Department in an amount not to exceed \$295,200 to provide electronic patient care records hosting and support services for the Contra Costa Emergency Medical Services System, for the period December 15, 2016 through December 14, 2019. (100% Measure H funds)

AYE: District I Supervisor John Gioia, District II Supervisor Candace Andersen, District III Supervisor Mary N. Piepho, District IV Supervisor Karen Mitchoff, District V Supervisor Federal D. Glover

- C. 35** APPROVE and AUTHORIZE the Health Services Director, or designee, to execute a contract with Mark Kogan, M.D., in an amount not to exceed \$450,000 to provide gastroenterology services at the Contra Costa Regional Medical Center and Health Centers, for the period January 1, 2017 through December 31, 2019. (100% Hospital Enterprise Fund I)

AYE: District I Supervisor John Gioia, District II Supervisor Candace Andersen, District III Supervisor Mary N. Piepho, District IV Supervisor Karen Mitchoff, District V Supervisor Federal D. Glover

- C. 36** APPROVE and AUTHORIZE the Health Services Director, or designee, to execute a contract with Peter A. Castillo, M.D., Inc., in an amount not to exceed \$382,000 to provide urogynecology services at the Contra Costa Regional Medical Center and Health Centers, for the period December 1, 2016 through November 30, 2017. (100% Hospital Enterprise Fund I)

AYE: District I Supervisor John Gioia, District II Supervisor Candace Andersen, District III Supervisor Mary N. Piepho, District IV Supervisor Karen Mitchoff, District V Supervisor Federal D. Glover

- C. 37** APPROVE and AUTHORIZE the Director of Human Resources, or designee, to execute a contract amendment including modified indemnification language with Benefit Coordinators Corporation, to extend the term from September 2, 2016 through August 31, 2017 and increase the payment limit by \$75,000 to a new payment limit of \$150,000, to assist the County in complying with the reporting and eligibility requirements of the Affordable Care Act.

AYE: District I Supervisor John Gioia, District II Supervisor Candace Andersen, District III Supervisor Mary N. Piepho, District IV Supervisor Karen Mitchoff, District V Supervisor Federal D. Glover

- C. 38** APPROVE and AUTHORIZE the Purchasing Agent to execute, on behalf of the Health Services Director, a purchase order with The Sourcing Group Company in an amount not to exceed \$800,000 for medical forms, envelopes and business cards for the Contra Costa Regional Medical and Health Centers, for the period November 1, 2016 through October 31, 2018. (100% Hospital Enterprise Fund I)

AYE: District I Supervisor John Gioia, District II Supervisor Candace Andersen, District III Supervisor Mary N. Piepho, District IV Supervisor Karen Mitchoff, District V Supervisor Federal D. Glover

- C. 39** APPROVE and AUTHORIZE the Purchasing Agent to execute, on behalf of the Health Services Director, a purchase order amendment with Freedom Hygiene, Inc., to increase the payment limit by \$38,000 to a new payment limit of \$128,000, with no change in the original term of January 12, 2015 through July 11, 2017, for disposal bins located at the Contra Costa Regional Medical and Health Centers. (100% Hospital Enterprise Fund I)

AYE: District I Supervisor John Gioia, District II Supervisor Candace Andersen, District III Supervisor Mary N. Piepho, District IV Supervisor Karen Mitchoff, District V Supervisor Federal D. Glover

- C. 40** APPROVE and AUTHORIZE the Purchasing Agent or designee to execute, on behalf of the Probation Department, a purchase order amendment with Bay Cities Produce Co., Inc. to increase the payment limit from \$95,000 to a new payment limit of \$245,000, for the purchase of whole and processed fresh fruits and vegetables at Juvenile Hall and Orin Allen Youth Rehabilitation Facility and to extend the term from December 31, 2016 to December 31, 2017. (100% General Fund)

AYE: District I Supervisor John Gioia, District II Supervisor Candace Andersen, District III Supervisor Mary N. Piepho, District IV Supervisor Karen Mitchoff, District V Supervisor Federal D. Glover

- C. 41** APPROVE and AUTHORIZE the Health Services Director, or designee, to execute a contract containing modified indemnification language with Young Men's Christian Association of the East Bay in an amount not to exceed \$10,000, to provide internship programs in the Workforce Education and Training Program for mental health students for the period October 1, 2016 through September 30, 2017. (100% Mental Health Services Act)

AYE: District I Supervisor John Gioia, District II Supervisor Candace Andersen, District III Supervisor Mary N. Piepho, District IV Supervisor Karen Mitchoff, District V Supervisor Federal D. Glover

- C. 42** APPROVE and AUTHORIZE the Health Services Director, or designee, to execute a contract with Cardionet, LLC, in an amount not to exceed \$135,000 to provide remote cardiac monitoring services for Contra Costa Regional Medical Center patients, for the period November 1, 2016 through October 31, 2017. (100% Hospital Enterprise Fund I)

AYE: District I Supervisor John Gioia, District II Supervisor Candace Andersen, District III Supervisor Mary N. Piepho, District IV Supervisor Karen Mitchoff, District V Supervisor Federal D. Glover

- C. 43** APPROVE and AUTHORIZE the Employment and Human Services Director, or designee, to execute a contract containing modified indemnification language with Children's Hospital & Research Center at Oakland (dba UCSF Benioff Children's Hospital Oakland) in an amount not to exceed \$15,000 to provide reflective supervision training for the period October 1, 2016 through June 30, 2017. (100% Federal)

AYE: District I Supervisor John Gioia, District II Supervisor Candace Andersen, District III Supervisor Mary N. Piepho, District IV Supervisor Karen Mitchoff, District V Supervisor Federal D. Glover

- C. 44** APPROVE and AUTHORIZE the Health Services Director, or designee, to execute a contract amendment, effective October 31, 2016, with the U.S. Department of Veterans Affairs, Northern California Health Care System, to extend the term from October 31, 2016 through December 31, 2017 and increase the payment limit by \$800,000 to a new payment limit of \$3,161,000 for continuation of nuclear medicine services to Contra Costa Regional Medical Center's Nuclear Medicine Unit. (100% Hospital Enterprise Fund I)

AYE: District I Supervisor John Gioia, District II Supervisor Candace Andersen, District III Supervisor Mary N. Piepho, District IV Supervisor Karen Mitchoff, District V Supervisor Federal D. Glover

- C. 45 APPROVE and AUTHORIZE the Purchasing Agent or designee to execute, on behalf of the Chief Information Officer-Department of Information Technology, a blanket purchase order with Graybar Electric Company in an amount not to exceed \$2,000,000 for the procurement of radio, telecommunications equipment and parts as needed, for the period January 1 through December 31, 2017. (100% User Fees)

*RELISTED to November 15, 2016.*

- C. 46 APPROVE and AUTHORIZE the Purchasing Agent to execute, on behalf of the Animal Services Director, a purchase order amendment with MWI Animal Health to extend the term from December 30, 2016 through September 30, 2017 with no change in the payment limit of \$700,000, to procure medical and shelter supplies. (No fiscal impact)

AYE: District I Supervisor John Gioia, District II Supervisor Candace Andersen, District III Supervisor Mary N. Piepho, District IV Supervisor Karen Mitchoff, District V Supervisor Federal D. Glover

- C. 47 APPROVE and AUTHORIZE the Sheriff-Coroner, or designee, to execute a contract with AtHoc Inc., in an amount not to exceed \$3,800,000 for the provision of proprietary software maintenance for the County's Community Warning System for the period of July 1, 2016 through June 30, 2021. (100% Certified Unified Program Administration funding)

AYE: District I Supervisor John Gioia, District II Supervisor Candace Andersen, District III Supervisor Mary N. Piepho, District IV Supervisor Karen Mitchoff, District V Supervisor Federal D. Glover

- C. 48 APPROVE and AUTHORIZE the Chief Information Officer-Department of Information Technology, or designee, to execute a Master Services Agreement with GrantStream, Inc., in an amount not to exceed \$68,000 to replace the Department of Information Technology's current grant management software application with GrantStream's Benevity Software-as-a-Service grant management application, for the period November 1, 2016 through October 31, 2017. (100% Department user fees)

AYE: District I Supervisor John Gioia, District II Supervisor Candace Andersen, District III Supervisor Mary N. Piepho, District IV Supervisor Karen Mitchoff, District V Supervisor Federal D. Glover

- C. 49 APPROVE and AUTHORIZE the Director of Child Support Services, or designee, to execute a contract amendment with Robert Half International, Inc., to extend the term from September 30 through December 31, 2016 and increase the payment limit by \$60,000 to a new payment limit of \$136,000, to provide information technology professional staff on a temporary basis, . (66% Federal, 34% State)

AYE: District I Supervisor John Gioia, District II Supervisor Candace Andersen, District III Supervisor Mary N. Piepho, District IV Supervisor Karen Mitchoff, District V Supervisor Federal D. Glover

### **Other Actions**

- C. 50 ADOPT Resolution No. 2016/581 to join the CaliforniaFirst Property Assessed Clean Energy financing program and AUTHORIZE the Conservation and Development Director, or designee, to execute an Operating Agreement with the California Statewide Communities Development Authority, and an Indemnification and Insurance Agreement with Renew Financial Group, LLC, as recommended by the Conservation and Development Director. (No fiscal impact)

AYE: District I Supervisor John Gioia, District II Supervisor Candace Andersen, District III Supervisor Mary N. Piepho, District IV Supervisor Karen Mitchoff, District V Supervisor Federal D. Glover

- C. 51** ADOPT Resolution No. 2016/614 authorizing the sale of specified tax-defaulted property at public auction, pursuant to the California Revenue and Taxation Code §3698, as recommended by the Treasurer-Tax Collector.

AYE: District I Supervisor John Gioia, District II Supervisor Candace Andersen, District III Supervisor Mary N. Piepho, District IV Supervisor Karen Mitchoff, District V Supervisor Federal D. Glover

- C. 52** APPROVE the list of providers recommended by the Contra Costa Health Plan's Medical Director on September 29, 2016 and by the Health Services Director, as required by the State Departments of Health Care Services and Managed Health Care, and the Centers for Medicare and Medicaid Services.

AYE: District I Supervisor John Gioia, District II Supervisor Candace Andersen, District III Supervisor Mary N. Piepho, District IV Supervisor Karen Mitchoff, District V Supervisor Federal D. Glover

- C. 53** APPROVE and AUTHORIZE the Health Services Director, or designee, to execute a contract amendment, effective October 1, 2016, with Carrington College, to allow medical laboratory assistants to receive field instruction at Contra Costa Regional Medical Center and Health Centers, with no change in the original term of July 1, 2012 to June 30, 2020. (Non-financial agreement)

AYE: District I Supervisor John Gioia, District II Supervisor Candace Andersen, District III Supervisor Mary N. Piepho, District IV Supervisor Karen Mitchoff, District V Supervisor Federal D. Glover

- C. 54** APPROVE and AUTHORIZE the Employment and Human Services Director, or designee, to execute a memorandum of understanding with Community Financial Resources, Inc., for a financial literacy and money management project for the period September 1, 2016 through February 15, 2017. (No fiscal impact)

AYE: District I Supervisor John Gioia, District II Supervisor Candace Andersen, District III Supervisor Mary N. Piepho, District IV Supervisor Karen Mitchoff, District V Supervisor Federal D. Glover

- C. 55** ADOPT the 2017 meeting schedule for the Contra Costa County Board of Supervisors, including the cancelation of those meetings at which it is anticipated that there will not be a quorum of Board members present, as well as fixing the dates for the specified events planned for the year, as recommended by the County Administrator.

AYE: District I Supervisor John Gioia, District II Supervisor Candace Andersen, District III Supervisor Mary N. Piepho, District IV Supervisor Karen Mitchoff, District V Supervisor Federal D. Glover

- C. 56** ADOPT Resolution No. 2016/630 authorizing the issuance and sale of "Brentwood Union School District General Obligation Bonds, Election of 2016, Series 2016" in an amount not to exceed \$25,000,000 by the Brentwood Union School District on its own behalf pursuant to Section 15140(b) of the Education Code, as recommended by the County Administrator. (No County fiscal impact)

AYE: District I Supervisor John Gioia, District II Supervisor Candace Andersen, District III Supervisor Mary N. Piepho, District IV Supervisor Karen Mitchoff, District V Supervisor Federal D. Glover

### **GENERAL INFORMATION**

The Board meets in all its capacities pursuant to Ordinance Code Section 24-2.402, including as the Housing Authority and the Successor Agency to the Redevelopment Agency. Persons who wish to address the Board should complete the form provided for that purpose and furnish a copy of any written statement to the Clerk.

Any disclosable public records related to an open session item on a regular meeting agenda and distributed by the Clerk of the Board to a majority of the members of the Board of Supervisors less than 72 hours prior to that meeting are available for public inspection at 651 Pine Street, First Floor, Room 106, Martinez, CA 94553, during normal business hours.

All matters listed under CONSENT ITEMS are considered by the Board to be routine and will be enacted by one motion. There will be no separate discussion of these items unless requested by a member of the Board or a member of the public prior to the time the Board votes on the motion to adopt.

Persons who wish to speak on matters set for PUBLIC HEARINGS will be heard when the Chair calls for comments from those persons who are in support thereof or in opposition thereto. After persons have spoken, the hearing is closed and the matter is subject to discussion and action by the Board. Comments on matters listed on the agenda or otherwise within the purview of the Board of Supervisors can be submitted to the office of the Clerk of the Board via mail: Board of Supervisors, 651 Pine Street Room 106, Martinez, CA 94553; by fax: 925-335-1913.

The County will provide reasonable accommodations for persons with disabilities planning to attend Board meetings who contact the Clerk of the Board at least 24 hours before the meeting, at (925) 335-1900; TDD (925) 335-1915. An assistive listening device is available from the Clerk, Room 106.

Copies of recordings of all or portions of a Board meeting may be purchased from the Clerk of the Board. Please telephone the Office of the Clerk of the Board, (925) 335-1900, to make the necessary arrangements.

Forms are available to anyone desiring to submit an inspirational thought nomination for inclusion on the Board Agenda. Forms may be obtained at the Office of the County Administrator or Office of the Clerk of the Board, 651 Pine Street, Martinez, California.

Applications for personal subscriptions to the weekly Board Agenda may be obtained by calling the Office of the Clerk of the Board, (925) 335-1900. The weekly agenda may also be viewed on the County's Internet Web Page: [www.co.contra-costa.ca.us](http://www.co.contra-costa.ca.us)

### **STANDING COMMITTEES**

The **Airport Committee** (Supervisors Karen Mitchoff and Mary N. Piepho) meets quarterly on the fourth Monday of the month at 12:30 p.m. at Director of Airports Office, 550 Sally Ride Drive, Concord.

The **Family and Human Services Committee** (Supervisors Candace Andersen and Federal D. Glover) meets on the first Monday of the month at 1:00 p.m. in Room 101, County Administration Building, 651 Pine Street, Martinez.

The **Finance Committee** (Supervisors Federal D. Glover and John Gioia) meets on the second Monday of the month at 1:30 p.m. in Room 101, County Administration Building, 651 Pine Street, Martinez.

The **Hiring Outreach Oversight Committee** (Supervisors John Gioia and Federal Glover) To be determined

The **Internal Operations Committee** (Supervisors Candace Andersen and Karen Mitchoff) meets on the second Monday of the month at 9:00 a.m. in Room 101, County Administration Building, 651 Pine Street, Martinez.

The **Legislation Committee** (Supervisors Karen Mitchoff and Mary N. Piepho) meets on the first Thursday of the month at 11:00 a.m. in Room 101, County Administration Building, 651 Pine Street, Martinez.

The **Public Protection Committee** (Supervisors John Gioia and Federal D. Glover) meets on the second Monday of the month at 11:00 a.m. in Room 101, County Administration Building, 651 Pine Street, Martinez.

The **Transportation, Water & Infrastructure Committee** (Supervisors Candace Andersen and Mary N. Piepho) meets on the first Thursday of the month at 1:30 p.m. in Room 101, County Administration Building, 651 Pine Street, Martinez.

Ad Hoc on Sustainability Committee	TBD	TBD	See Above
Airports Committee	December 28, 2016	1:30 p.m.	See above
Family & Human Services Committee	November 14, 2016	1:00 p.m.	See above
Finance Committee	November 10, 2016	10:30 a.m.	See above
Hiring Outreach Oversight Committee	December 12, 2016	9:00 a.m.	See above
Internal Operations Committee	November 28, 2016 cancelled Special meeting December 12, 2016 Rm. 107	11:00 a.m.	See above
Legislation Committee	November 14, 2016	10:30 a.m.	See above
Public Protection Committee	November 28, 2016 cancelled Special meeting December 12, 2016 Rm. 107	10:00 a.m.	See above
Transportation, Water & Infrastructure Committee	November 10, 2016	1:00 p.m.	See above

**PERSONS WHO WISH TO ADDRESS THE BOARD DURING PUBLIC COMMENT OR WITH RESPECT TO AN ITEM THAT IS ON THE AGENDA, MAY BE LIMITED TO TWO (2) MINUTES**

**A LUNCH BREAK MAY BE CALLED AT THE DISCRETION OF THE BOARD CHAIR**

**AGENDA DEADLINE: Thursday, 12 noon, 12 days before the Tuesday Board meetings.**

**Glossary of Acronyms, Abbreviations, and other Terms (in alphabetical order):**

Contra Costa County has a policy of making limited use of acronyms, abbreviations, and industry-specific language in its Board of Supervisors meetings and written materials. Following is a list of commonly used language that may appear in oral presentations and written materials associated with Board meetings:

**AB** Assembly Bill



**ABAG** Association of Bay Area Governments  
**ACA** Assembly Constitutional Amendment  
**ADA** Americans with Disabilities Act of 1990  
**AFSCME** American Federation of State County and Municipal Employees  
**AICP** American Institute of Certified Planners  
**AIDS** Acquired Immunodeficiency Syndrome  
**ALUC** Airport Land Use Commission  
**AOD** Alcohol and Other Drugs  
**ARRA** American Recovery & Reinvestment Act of 2009  
**BAAQMD** Bay Area Air Quality Management District  
**BART** Bay Area Rapid Transit District  
**BayRICS** Bay Area Regional Interoperable Communications System  
**BCDC** Bay Conservation & Development Commission  
**BGO** Better Government Ordinance  
**BOS** Board of Supervisors  
**CALTRANS** California Department of Transportation  
**CalWIN** California Works Information Network  
**CalWORKS** California Work Opportunity and Responsibility to Kids  
**CAER** Community Awareness Emergency Response  
**CAO** County Administrative Officer or Office  
**CCCPCFD (ConFire)** Contra Costa County Fire Protection District  
**CCHP** Contra Costa Health Plan  
**CCTA** Contra Costa Transportation Authority  
**CCRMC** Contra Costa Regional Medical Center  
**CCWD** Contra Costa Water District  
**CDBG** Community Development Block Grant  
**CFDA** Catalog of Federal Domestic Assistance  
**CEQA** California Environmental Quality Act  
**CIO** Chief Information Officer  
**COLA** Cost of living adjustment  
**ConFire (CCCPCFD)** Contra Costa County Fire Protection District  
**CPA** Certified Public Accountant  
**CPI** Consumer Price Index  
**CSA** County Service Area  
**CSAC** California State Association of Counties  
**CTC** California Transportation Commission  
**dba** doing business as  
**DSRIP** Delivery System Reform Incentive Program  
**EBMUD** East Bay Municipal Utility District  
**ECCPCFD** East Contra Costa Fire Protection District  
**EIR** Environmental Impact Report  
**EIS** Environmental Impact Statement  
**EMCC** Emergency Medical Care Committee  
**EMS** Emergency Medical Services  
**EPSDT** Early State Periodic Screening, Diagnosis and Treatment Program (Mental Health)  
**et al.** et alii (and others)  
**FAA** Federal Aviation Administration  
**FEMA** Federal Emergency Management Agency  
**F&HS** Family and Human Services Committee  
**First 5** First Five Children and Families Commission (Proposition 10)  
**FTE** Full Time Equivalent  
**FY** Fiscal Year  
**GHAD** Geologic Hazard Abatement District  
**GIS** Geographic Information System  
**HCD** (State Dept of) Housing & Community Development

**HHS** (State Dept of ) Health and Human Services  
**HIPAA** Health Insurance Portability and Accountability Act  
**HIV** Human Immunodeficiency Syndrome  
**HOV** High Occupancy Vehicle  
**HR** Human Resources  
**HUD** United States Department of Housing and Urban Development  
**IHSS** In-Home Supportive Services  
**Inc.** Incorporated  
**IOC** Internal Operations Committee  
**ISO** Industrial Safety Ordinance  
**JPA** Joint (exercise of) Powers Authority or Agreement  
**Lamorinda** Lafayette-Moraga-Orinda Area  
**LAFCo** Local Agency Formation Commission  
**LLC** Limited Liability Company  
**LLP** Limited Liability Partnership  
**Local 1** Public Employees Union Local 1  
**LVN** Licensed Vocational Nurse  
**MAC** Municipal Advisory Council  
**MBE** Minority Business Enterprise  
**M.D.** Medical Doctor  
**M.F.T.** Marriage and Family Therapist  
**MIS** Management Information System  
**MOE** Maintenance of Effort  
**MOU** Memorandum of Understanding  
**MTC** Metropolitan Transportation Commission  
**NACo** National Association of Counties  
**NEPA** National Environmental Policy Act  
**OB-GYN** Obstetrics and Gynecology  
**O.D.** Doctor of Optometry  
**OES-EOC** Office of Emergency Services-Emergency Operations Center  
**OPEB** Other Post Employment Benefits  
**OSHA** Occupational Safety and Health Administration  
**PARS** Public Agencies Retirement Services  
**PEPRA** Public Employees Pension Reform Act  
**Psy.D.** Doctor of Psychology  
**RDA** Redevelopment Agency  
**RFI** Request For Information  
**RFP** Request For Proposal  
**RFQ** Request For Qualifications  
**RN** Registered Nurse  
**SB** Senate Bill  
**SBE** Small Business Enterprise  
**SEIU** Service Employees International Union  
**SUASI** Super Urban Area Security Initiative  
**SWAT** Southwest Area Transportation Committee  
**TRANSPAC** Transportation Partnership & Cooperation (Central)  
**TRANSPLAN** Transportation Planning Committee (East County)  
**TRE** or **TTE** Trustee  
**TWIC** Transportation, Water and Infrastructure Committee  
**UASI** Urban Area Security Initiative  
**VA** Department of Veterans Affairs  
**vs.** versus (against)  
**WAN** Wide Area Network  
**WBE** Women Business Enterprise  
**WCCTAC** West Contra Costa Transportation Advisory Committee





Contra  
Costa  
County

To: Board of Supervisors  
From: William Walker, M.D., Health Services Director  
Date: November 1, 2016

Subject: Recognizing September 2016 as Homelessness Awareness Month in Contra Costa County

---

**RECOMMENDATION(S):**

ACCEPT the presentation recognizing November 2016 as Homeless Awareness month in Contra Costa County.

**FISCAL IMPACT:**

None.

**BACKGROUND:**

Hunger and Homelessness Awareness Week, sponsored by the National Coalition for the Homeless, is November 12-20, 2016. This dedicated week offers the opportunity to call attention to the problems of hunger and homelessness across the nation. Throughout the month of November, the Council on Homelessness will join the national effort to highlight the various housing and homelessness issues in our community and showcase the myriad efforts within the homeless Continuum of Care that is making a real impact on reducing homelessness.

A 2016 Homelessness Awareness Toolkit has been developed to support the Council's efforts to get the community more involved through education, advocacy, and service. Throughout November, Council on Homelessness members will

---

<input checked="" type="checkbox"/> APPROVE	<input type="checkbox"/> OTHER
<input checked="" type="checkbox"/> RECOMMENDATION OF CNTY ADMINISTRATOR	<input type="checkbox"/> RECOMMENDATION OF BOARD COMMITTEE

---

Action of Board On: **11/01/2016**  APPROVED AS  
RECOMMENDED  OTHER

Clerks Notes:

**VOTE OF SUPERVISORS**

AYE: John Gioia, District I Supervisor  
Candace Andersen, District II  
Supervisor  
Mary N. Piepho, District III Supervisor  
Karen Mitchoff, District IV Supervisor  
Federal D. Glover, District V Supervisor

I hereby certify that this is a true and correct copy of an action taken and entered on the minutes of the Board of Supervisors on the date shown.

ATTESTED: November 1, 2016

David J. Twa, County Administrator and Clerk of the Board of Supervisors

Contact: Lavonna Martin, (925)  
313-7700

By: Stephanie Mello, Deputy

cc:

BACKGROUND: (CONT'D)

be making presentations before various local city councils to educate each community about how homelessness impacts their community. Throughout the month and leading up to the holidays, community members may choose to donate their time and services to support homeless service agencies and individuals in need. Additionally, the Council, in concert with the Health, Housing, and Homeless Services division will be hosting presentations throughout the month on Contra Costa's homeless system of care and the changes underway to develop a more efficient, coordinated entry into homeless services for the 1,700 individuals who are homeless each night.

ATTACHMENTS

Homeless Awareness Toolkit

# Contra Costa County 2016 Homelessness Awareness Toolkit

Promoting education, advocacy, and service to end homelessness in our community

During the month of November, Contra Costa will join national efforts to increase awareness and promote solutions to ending homelessness. Every night there are approximately 1,700 homeless men, women, and children in Contra Costa County. We each play a part in ending homelessness in our community.

## How will you get involved?



### Educate

- ✓ Know the **statistics** of homeless in your community
- ✓ Learn about **our strategies** to end homelessness
- ✓ Learn about the local **Contra Costa Zero: 2016** campaign to end chronic and veteran homelessness, **National Hunger and Homelessness Awareness Week** and what Housing First means

### Advocate

- ✓ Talk to your **city/town council** about **options** to help address homelessness in your community.
- ✓ Encourage landlords to **learn more** about renting to homeless individuals
- ✓ Forward/repost this toolkit to others interested in homelessness

### Service

- ✓ **Donate** to the Contra Costa Housing Security Fund
- ✓ **Volunteer** with your local church or service provider
- ✓ **Donate** to a local homeless provider

\*Data from 2016 Contra Costa PIT Count

1350 Arnold Dr., Ste. 202, Martinez, CA/925-313-7700

[homelessprogram@hsd.cccounty.us](mailto:homelessprogram@hsd.cccounty.us) / [cchealth.org/homeless](http://cchealth.org/homeless)



# November 2016



Sunday	Monday	Tuesday	Wednesday	Thursday	Friday	Saturday
		1	2	3	4	5
	Grab extra toiletries next time you stay at a hotel and <a href="#">donate them</a> when you return. 	<a href="#">Council on Homelessness @ Board of Supervisors</a>				Clean out your closets this weekend and <a href="#">donate</a> extra clothes 
6	7	8	9	10	11	12
Research upcoming coat drives in your area. 		Donate to the <a href="#">Contra Costa Housing Security Fund!</a> 		 <b>VETERANS DAY</b> <a href="#">Help us house our homeless veterans</a>		
13	14	15	16	17	18	19
			Consider donating to the Food Bank of Contra Costa and Solano <a href="#">Holiday Fund Drive</a>  of Contra Costa & Solano		<a href="#">Project Hope Memorial Event</a>	<a href="#">Together We Give Events</a>  <a href="#">Shelter Inc. Holiday Box Assembly</a>
20	21	22	23	24	25	26
<a href="#">Thanksgiving Multi-Faith Celebration and Service</a>		Check with local congregations to see if they need help serving food on Thanksgiving. 		<b>THANKSGIVING DAY</b> <a href="#">Trinity Center Meal</a> <a href="#">First Lutheran Church Meal</a> 		



# HOMELESS AWARENESS MONTH EVENTS

Below is a list of open houses and tours that homeless service providers in Contra Costa County will be offering during Homeless Awareness Month.

## Tuesday, November 1<sup>th</sup>

### **Council on Homelessness presents Hunger and Homeless Awareness Week to Contra Costa Board of Supervisors**

**9:30ish** (check to see when on agenda [here](#))  
**651 Pine Street, Martinez (Board Chambers)**

Members of the Council on Homelessness will present information about homelessness in Contra Costa and about Hunger and Homelessness Awareness week to the Contra Costa Board of Supervisors. Community members are encouraged to attend and to stand while speakers talk as a show of support for the Board's continued focus on homelessness.

## Friday, November 18<sup>th</sup>

### **Project Hope Memorial Event**

**10 a.m. to 1 p.m. (lunch at Noon)**  
**Concord United Methodist Church, 1645 West Street, Concord**

Twelfth annual Memorial Service- a celebration of life for the homeless men and women who have passed over the last year.

## Saturday, November 19<sup>th</sup>

### **Together We Give**

#### **CENTRAL COUNTY**

**9:00 a.m. -12:00 p.m.**  
**St. Paul's Episcopal Church, Parish Hall**  
1924 Trinity Avenue, Walnut Creek, CA

#### **EAST COUNTY**

**1:00 p.m. -4:00 p.m.**  
**Opportunity Junction**  
3102 Delta Fair Blvd., Antioch, CA

#### **WEST COUNTY**

**2:00 p.m.-5:00 p.m.**  
**GRIP Souper Center**  
165 22nd Street, Richmond, CA

On November 19th, clean out your closets, recycle, donate and help others through Together We Give's Community Donation Day. **For details about what items are being requested at each location, go to [www.togetherwegive.org](http://www.togetherwegive.org).**





## **SHELTER, Inc. Holiday Box Assembly**

**9:00am - 11:00am**

**1333 Willow Pass Road, Suite 206, Concord, CA 94520**

Volunteers sort nonperishable food items and assemble 400+ boxes of Thanksgiving food items that will be distributed to families. Consider donating food items or grocery store gift cards (\$10-\$20) to add to the boxes. Contact Theresita Gonzalez, Community Resource Coordinator at [TheresitaG@shelterinc.org](mailto:TheresitaG@shelterinc.org) or call (925) 957-5761.

**Sunday, November 20<sup>th</sup>**

### **Thanksgiving Multi-Faith Celebration and Service**

**4 p.m.**

**Temple Isaiah, 945 Risa Rd, Lafayette, CA 94549**

Share gratitude for abundance - Commit to confronting poverty. Gather in community! Faith leaders from across the County with a Multi-Faith choir led by Joyce Pricco, St. Michael & All Angels Episcopal Church. Offering received at this service will be donated to the [Contra Costa County Housing Security Fund](#). For more information contact the Multi-Faith ACTION Coalition [contactmfac@gmail.com](mailto:contactmfac@gmail.com)

**Thursday, November 24<sup>th</sup>**

### **Trinity Center Thanksgiving Meal**

**1:00 pm – 3:00 pm**

**St. Paul's Episcopal Church, 1924 Trinity Avenue, Walnut Creek.**

Last year, with the help of donations from the Contra Costa and Solano Food Bank, Share the Spirit program (Volunteer Centers of the East Bay), Trinity Center staff and volunteers, St. Paul's volunteers and volunteers from the community, we served over 120 meals. We hope to serve this many folks again this year!

### **First Lutheran Church Giving Thanks Meal**

**11:30 am – 3:00 pm**

**First Lutheran Church, 4000 Concord Blvd., Concord**

All people in need in the Concord area will have the opportunity to join us on Thanksgiving Day for a hot, home style meal served with love. Several local churches are planning the ninth annual Giving Thanks at Thanksgiving. This meal is for anyone in need of a hot meal, cooked with love, on Thanksgiving. If you have questions about the meal call 925-207-0035 and leave a message or send an email to [GTatTG@yahoo.com](mailto:GTatTG@yahoo.com), we will get back to you as soon as possible. NOTE: We can provide transportation to the meal, in the local area. If you need a ride contact us as above.

# VOLUNTEER OPPORTUNITIES

Below is a list of volunteer opportunities with the Contra Costa Council on Homelessness. Some of the opportunities are available throughout the year, and others are specific to the fall and winter holidays.

## Contra Costa Interfaith Housing

### What?

Tutoring youth in afterschool programs

### When?

Varies

### Contact?

Email [Gloria@ccinterfaithhousing.org](mailto:Gloria@ccinterfaithhousing.org) or call 925-448-2004.

## Monument Crisis Center

### What?

Help with Food Pantry and Client Intake

### When?

Monday – Thursday 9 am - Noon

### Contact?

Email [Volunteer@monumentcrisiscenter.org](mailto:Volunteer@monumentcrisiscenter.org) or call (925) 825-7751 for more information.

## Trinity Center

### What?

Evening Program volunteers including cooks, van drivers, floor monitors, weekend breakfast/lunch bags.

### When?

Nov 12 – Mar 30.

### Contact?

Coordinator: Nora Hudson, [norah@trinitycenterwc.org](mailto:norah@trinitycenterwc.org)

## Trinity Center

### What?

Thanksgiving food prep and serving:

### When?

November 24th

### Contact?

Carol Lombard, 925-949-8712

## DONATION WISH LIST

Below is a list of partner agencies in the Contra Costa Council on Homelessness and their donation wish lists. These are items that can be donated throughout the year:

**Also see the “Together We Give” event on November 19<sup>th</sup> in the Events Section above!**

### ANKA Behavioral Health

- Socks
- Sweatpants and sweatshirts
- Sleeping bags
- Bottled water
- Can openers

**Call (925) 270-2102 to coordinate drop off.**

### Calli House Youth Shelter

- Twin size bedding (sheets and comforters)
- Pillows
- Bath towels
- Hygiene products: shampoo, body soap, deodorant, lotion, feminine products, sponges, toothbrushes/paste, hairproducts, flipflops, shaving cream/razors
- Clothing: socks, tshirts, male/female undergarments, pajamas
- School supplies
- Gift cards for youth birthdays, moving into permanent housing, etc. (safeway, Target, Walmart, Dollar Store, Movie theater, payless shoes)
- Warm coats
- Umbrellas
- Pots/pans
- Arts/crafts supplies
- Duffle bags/small suitcases for youth to travel between programs

**Call (510) 541-7562 to coordinate drop off**

### Contra Costa Housing Security Fund

The Contra Costa Housing Security Fund is a community fund that covers costs that can prevent many people, including seniors, veterans and families from getting back into housing and protects property owners who offer these screened renters an opportunity.

**To donate, go to <http://tinyurl.com/HousingSecurityFund>**

#### Resources for Renters

Credit Check  
Application fees  
Utility deposit  
Utility arrears  
Rental Assistance (short term)  
Security Deposit

#### Resources for Landlords

Repair damage to units  
Pay past-due rent (eviction prevention)  
Increased security deposit



The fund is utilized by service providers in the Contra Costa Homeless Continuum of Care, is managed by the Contra Costa Crisis Center and held by the Richmond Community Foundation. All donations are tax-deductible.

**To donate, go to <http://tinyurl.com/HousingSecurityFund>**

For questions about the fund, please email [jaime.jenett@hsd.cccounty.us](mailto:jaime.jenett@hsd.cccounty.us).

### **Contra Costa Interfaith Housing**

- Grocery gift cards
- Diapers
- Feminine Hygiene products
- Bed Bug mattress encasements (all sizes)

**Call 925-448-2004 or email [Gloria@ccinterfaithhousing.org](mailto:Gloria@ccinterfaithhousing.org) to coordinate drop off.**

### **First Lutheran Church**

- New socks, all sizes
- New or gently used blankets/sleeping bags
- Coats & gloves for distribution after the meal.

Monetary donations to offset the cost of the food for the Thanksgiving meal may be made out to First Lutheran Church and brought or mailed to 4000 Concord Blvd, Concord, CA 94519.

**You may bring any donations to First Lutheran Church, on weekdays between 9 AM and 3:30 pm until the day before Thanksgiving. If you cannot drop your donation off during these hours, call 925-708-0898 and leave a message to arrange a drop off time. Monetary donations to offset the cost of the food may be made out to First Lutheran Church and brought or mailed to 4000 Concord Blvd, Concord, CA 94519.**

### **Loaves and Fishes**

- Canned soups and vegetables
- Cereals
- Peanut butter
- Pasta and canned sauce
- Rice
- Healthy snacks: energy bars, granola bars
- Canned meats: chicken, beef, fish, chili and beef stew.
- Toiletries: tooth paste, shampoo, toothbrushes, deodorant, soap
- Kitchen cleaning supplies: dish soap and scrub pads

**Drop off can be arranged by emailing [info@loavesfishescc.org](mailto:info@loavesfishescc.org).**

## Monument Crisis Center December Cheer (Nov 28th- Dec 26th)

- New adult size sleeping bags (preferably good to 30/40 degrees)
- New tarps 6x8 or 8x10
- Ready-to-eat food items
- Can openers
- New knit scarves, hats and gloves

Email or call Danny Scherer at [dscherer@monumentcrisiscenter.org](mailto:dscherer@monumentcrisiscenter.org) or 925.222.6866 for more details.

## Monument Crisis Center Holiday Food Box

- Details can be found here: <http://monumentcrisiscenter.org/wp-content/uploads/2012/05/Holiday-Food-Box-2016-1.pdf>

Email or call Danny Scherer at [dscherer@monumentcrisiscenter.org](mailto:dscherer@monumentcrisiscenter.org) or 925.222.6866 for more details.

## Trinity Center

- Non-perishable food items
- Clothing
- Blankets
- Warm coats
- Holiday gift cards

Call 925-949-8712 to coordinate drop off

## Winter Nights

- Automobiles
- Gas, BART and bus cards
- Packing or duct tape
- Industrial dispenser for packing tape
- Sleeping bags (new or cleaned)
- Umbrella strollers ( single & double)
- Pillows
- Twin size plastic mattress covers – non zipped
- Fitted single sheets (new or used)
- Target/Walmart cards
- Movie theater gift certificates
- Sanitary wipes
- Wardrobe boxes(24x21x48 size)

Call 925-933-6030 or email [eye4cee@aol.com](mailto:eye4cee@aol.com) to coordinate drop off



Contra  
Costa  
County

To: Board of Supervisors  
From: David Twa, County Administrator  
Date: November 1, 2016

Subject: Other Post Employment Benefits (OPEB) - 2016 Valuation Report

---

**RECOMMENDATION(S):**

ACCEPT the 2016 Other Post Employment Benefits (OPEB) Valuation Report as of January 1, 2016 including Annual Required Contributions for the Fiscal Year Ending June 30, 2016.

**FISCAL IMPACT:**

The attached 2016 Other Post Employment Benefit (OPEB) Valuation Report is required per Governmental Accounting Standards Board (GASB) Statements 43 and 45 to be completed, by a County the size of Contra Costa, every two years. The report presents a calculation of liability and has no specific fiscal impact on its own. The County's actions to reduce the liability have had a significant positive impact on the County's overall fiscal stability and ability to deliver services. As of January 1, 2016, the most recent actuarial valuation date, the County's other post employment benefits were 18.6% funded. The actuarial accrued liability for benefits was \$939.1 million, and the actuarial value of assets was \$174.7 million, resulting in an unfunded actuarial accrued liability of \$764.3 million, and an Annual Required Contribution of \$89.2 million.

---

APPROVE

OTHER

RECOMMENDATION OF CNTY ADMINISTRATOR

RECOMMENDATION OF BOARD  
COMMITTEE

---

Action of Board On: **11/01/2016**  APPROVED AS RECOMMENDED  OTHER

Clerks Notes:

**VOTE OF SUPERVISORS**

AYE: John Gioia, District I Supervisor  
Candace Andersen, District II  
Supervisor  
Mary N. Piepho, District III Supervisor  
Karen Mitchoff, District IV Supervisor  
Federal D. Glover, District V  
Supervisor

I hereby certify that this is a true and correct copy of an action taken and entered on the minutes of the Board of Supervisors on the date shown.

ATTESTED: November 1, 2016

David J. Twa, County Administrator and Clerk of the Board of Supervisors

Contact: Lisa Driscoll, County  
Finance Director

By: June McHuen, Deputy

## BACKGROUND:

In 2004, due to growing concern over the potential magnitude of government employer obligations for post-employment benefits, the Governmental Accounting Standards Board enacted Statement 45 (GASB 45). The main reason for the Statement was to establish uniform accrual accounting and reporting of these governmental liabilities much like under the Financial Accounting Standards Board (FASB) rules that already applied to the private sector for OPEBs (and GASB 25 and 27 statements that already applied to governmental pension liabilities). Accrual accounting was needed to report the cost of providing government services over the working lifetime of employees providing the services rather than just the "pay-as-you-go" (paygo) cost that was not realized until after those employees retired.

Additionally, an intended audience of these GASB 45 results was the bond markets to allow better assessment of levels of government solvency in issuing debt. Although plan solvency was not the main impetus behind Statement 45, GASB 45 is considered 'funding friendly' because it adds some stability for those receiving the benefits, if those benefits are actually pre-funded. Because Statement 45 requires the public sector to account for total long term OPEB costs over the active service life of benefit-earning employees, rather than reporting current year OPEB costs only for existing retirees, it is thought that addressing these long-term liabilities would help to avoid the collapses in benefit plans that have occurred in the private sector.

Pursuant to GASB 45 requirements, Contra Costa County ordered its initial actuarial report in 2006. The 2006 report valued the County's unfunded liability for retiree medical costs at \$2.6 billion based upon a cash discount rate. This outstanding liability, if fully amortized over the following 30 years, would have necessitated an Annual Required Contribution (ARC) of \$216 million. At that point in time, \$216 million would have been six times the amount that the County was paying toward retiree health care costs on a paygo basis.

As is described in the attached 2016 report and in the table below, the County has taken significant actions to address GASB 45 and to reduce its OPEB liability since the initial report of 2006. Interim valuation results have been presented to the Board of Supervisors, pursuant to California Government Code 7507, since the 2008 report. However, for comparison purposes, the table below compares bi-annual GASB 45 valuation results at fiscal year-end (FYE).

	FYE 2006	FYE 2008	FYE 2010	FYE 2012	FYE 2014	FYE 2016
Total Accrued Actuarial Liability	2,571,650,000	2,367,023,000	1,046,113,000	1,033,801,000	923,848,000	939,053,000
Assets	0	0	25,048,000	65,491,000	129,426,000	174,724,000
Unfunded Accrued Actuarial Liability (UAAL)	2,571,650,000	2,367,023,000	1,021,065,000	968,310,000	794,422,000	764,329,000
Normal Cost	130,604,000	116,079,000	29,754,000	27,493,000	28,666,000	29,032,000
Amortization of UAAL	85,721,000	139,058,000	74,000,000	72,242,000	59,872,000	60,138,000
Annual Required Contribution (ARC)	216,325,000	255,137,000	103,754,000	99,735,000	88,538,000	89,170,000
Actives	8,428	8,563	8,013	7,720	8,089	8,645
Retirees and Survivors	4,856	5,813	5,251	5,941	6,206	6,396
Total Counts	13,284	14,376	13,264	13,661	14,295	15,041
Discount Rate	4.5%	4.5%	6.32%	6.32%	5.70%	5.70%

In June, 2007, the County established a funding target of 100% of the potential liability for the retiree population. At that time, retirees accounted for approximately 40% of the liability population. That figure is now 43% and expected to continue to grow. Partial pre-funding began in 2008 with an annual County allocation of \$20 million. The County's OPEB was 3.9% funded in 2010, 6.3% in 2012, 14% in 2014, and as of January 1, 2016, the County's OPEB was 18.6% funded. Although the County has made great strides towards reducing the liability, the current funded ratio is only 18.6%. Additionally, the UAAL as a percentage of covered payroll, is still high at 109.8%. Pursuant to County Ordinance No. 2014-04, the annual resources of \$20 million will be increased by \$47 million to \$67 million in FY 2022/23 when the County retires its current Pension Obligation Bond.

Both the 2006 and 2008 valuation reports used a 4.5% discount rate, reflecting the County's funding policy at that time. The 2010 and 2012 results reflected a 6.32% discount rate to reflect the County's adopted discount rate assumption based on \$20 million in partial pre-pay into an OPEB trust fund, plus paygo funding. The 2014 and

2016 reports reflects a 5.70% discount rate, which reflects the County's current policies. This rate is derived based upon the fund's investment policy, level of partial funding, and long-term inflation assumption. Based upon the portfolio's target allocation, the average return of Trust assets over the next 30 years is expected to be 6.25%. Because the County's annual contribution is not equal to the Annual Required Contribution, GASB requires that the rate be blended with the expected return of the County's general fund (we assumed a long term return of 3.5%).

Throughout the last eight years through labor negotiations, the County has worked with employees to adopt and implement the County's OPEB goals. Through the efforts of the majority of our employees, the County has adopted an OPEB financing plan that balanced the County's requirement to provide public services with its desire to provide competitive health care benefits to employees and fully complies with GASB 45. It is important to note that the significant improvement in the County's OPEB liability could not have been achieved without the support of our employees. These efforts will not only help to ensure the County's overall fiscal stability and ability to deliver services, but will also increase the likelihood that health care benefits will be available to our employees and retirees in the future.

A reconciliation of the County's valuation changes breaks out in the following way:

#### 2006 to 2008

- Updated Contra Costa County Employees' Retirement Association (CCCERA) pension valuation assumptions where applicable (valuation assumption)
- Better overall medical and dental plan trend and renewals over the two years than originally assumed (demographic gain)
- Fewer new retirements than originally assumed, which delayed the onset of benefits (demographic gain)
- Overall cleaner and more complete data than was available in 2006
- Effective 2008, the County contribution for non-represented retirees was set at the 2009 level for future years (this date was later changed to 2011 and included in subsequent valuation plan provisions)

#### 2008 to 2010

- Reduced liability due to the negotiated plan change savings over time. The impact from these changes was more than expected due to conservative plan change assumptions and up to date bargaining unit coding.
- Migration to lower cost plans as a result of the plan changes and a resulting lower subsidy amount (active rates subsidizing retiree rates).
- Demographic gains:
  - This was due to both active and retiree counts being lower than in the 2008 valuation,
  - Fewer new retirements than expected,
  - Fewer continuing retirees than expected, and
  - Fewer active employees than in 2008.

#### 2010 to 2012

- Reduced liability due to the negotiated plan change savings over time.
- Migration to lower cost plans as a result of the plan changes and a resulting lower subsidy amount.
- Demographic losses:
  - This was due to active counts being lower and retiree counts being higher than in the 2010 valuation,
  - More new retirements than expected (loss),
  - More retirees than in 2010 (loss), and
  - Fewer active employees than in 2010 (gain).

#### 2012 to 2014

- Reduced liability due to the negotiated plan change savings over time. See Appendix A of attached report (Summary of Benefits), for details regarding plan changes made for the majority of County employees.
- Migration to lower cost plans as a result of the plan changes and a resulting lower subsidy amount.
- Demographic losses:
  - Active and retiree counts were higher than in the 2012 valuation, however the ratio of actives to



- retirees remained at 43.4%,
- More new retirements than expected (loss),
  - More retirees than in 2012 (loss), and
  - More active employees than in 2012 (loss).

#### 2014 to 2016

- Increased liability due to certain negotiated plan changes. See Appendix A of attached report (Summary of Benefits), for details regarding plan changes made for the majority of County employees.
- Migration to lower cost plans as a result of the plan changes and a resulting lower subsidy amount.
- Demographic loss was very small at approximately \$3 million:
  - Active and retiree counts were higher than in the 2014 valuation, however the ratio of actives to retirees remained at 43%, and
  - More active employees than in 2014 (loss).

#### Summary

Over the last ten years, the County has reduced its OPEB UAAL by 63%, Normal Cost by 78%, amortization of UAAL by 29%, and Annual Required Contribution by 59%. Although the County's annual trust deposit of \$20 million combined with the annual paygo cost of \$46 million shows great progress, it does not meet the GASB definition of paying the total Annual Required Contribution for pre-funding (\$89.2 million). Additionally, a 18.6% funded level is still far from the targeted level of 43%. The Board of Supervisors, through the County Administrator's Office will continue to work towards a financial balance between the provision of necessary services to the public and provision of competitive health care benefits for employees and retirees.

None of these reductions could have been achieved without the support and cooperation of our employees. Continued negotiations toward Countywide health care cost containment strategies and the redirection of designated future resources remain key to reducing the OPEB liability. The Board of Supervisors continues to make significant progress toward a solution for one of the biggest fiscal challenges the County has faced to date.

The results contained in this report are our best estimate; however, variation from these or any other estimates of future retiree medical costs is possible. Actual future costs may vary from the estimates in this report. Detailed information on the Board's actions, including all of the County's OPEB reports, is available on the County's web-site at [www.cccounty.us/1318/Other-Post-Employment-Benefits](http://www.cccounty.us/1318/Other-Post-Employment-Benefits).

#### CONSEQUENCE OF NEGATIVE ACTION:

The County will be out of compliance with GASB 45.

#### ATTACHMENTS

2016 OPEB Valuation Report

---

## Contra Costa County

GASB 45 Actuarial Valuation of Post Employment  
Benefits Other than Pensions as of January 1, 2016

Prepared by:

**John R. Botsford**  
FSA, MAAA

**Milliman, Inc.**  
650 California Street, 17th Floor  
San Francisco, California 94108  
Tel 415 403 1333 Fax 415 403 1334  
milliman.com

October 18, 2016

---



650 California Street, 17th Floor  
San Francisco, CA 94108-2702  
USA

Tel +1 415 403 1333  
Fax +1 415 403 1334

milliman.com

October 18, 2016

Contra Costa County  
651 Pine Street  
Martinez, CA 94553

***Contra Costa County –  
GASB 45 Actuarial Valuation of Post Employment Benefits as of January 1, 2016***

At the request of the Contra Costa County, we have completed an actuarial valuation of other post employment benefits as of January 1, 2016.

The purpose of this report is to determine the Annual Required Contribution and required financial disclosures under the Governmental Accounting Standards Board Statement No. 45 – *Accounting and Financial Reporting by Employers for Postemployment Benefits Other Than Pensions* (GASB 45). Our determinations reflect the procedures and methods prescribed in GASB 45.

In preparing our report, we relied, without audit, on information supplied by Contra Costa County's staff. This information includes but not limited to employee census data, financial information and the County's other post employment benefit (OPEB) provisions. While Milliman has not audited the financial and census data, they have been reviewed for reasonableness and are, in our opinion, sufficient and reliable for the purposes of our calculations. If any of this information as summarized in this report is inaccurate or incomplete, the results shown could be materially affected and this report may need to be revised.

All costs, liabilities, rates of interest, and other factors for the County have been determined on the basis of actuarial assumptions and methods which are individually reasonable (taking into account the experience of the County and reasonable expectations); and which, in combination, offer our best estimate of anticipated experience affecting the County. Further, in our opinion, each actuarial assumption used is reasonably related to the experience of the County and to reasonable expectations which, in combination, represent our best estimate of anticipated experience for the County.

This valuation report is only an estimate of the County's other post employment benefit liability as of a single date. It can neither predict the future condition of the County's other post employment benefit liability nor guarantee future financial soundness. Actuarial valuations do not affect the ultimate cost of other post employment benefits. They may affect the timing of County contributions. While the valuation is based on an array of individually reasonable assumptions, other assumption sets may also be reasonable and valuation results based on those assumptions would be different. No one set of assumptions is uniquely correct. Determining results using alternative assumptions is outside the scope of our engagement.

Future actuarial measurements may differ significantly from the current measurements presented in this report due to such factors as the following: County experience differing from that anticipated by the economic or demographic assumptions; changes in economic or demographic assumptions;

increases or decreases expected as part of the natural operation of the methodology used for these measurements (such as the end of an amortization period); and changes in other post employment benefit provisions or applicable law. Due to the limited scope of our assignment, we did not perform an analysis of the potential range of future measurements. The County has the final decision regarding the appropriateness of the assumptions and actuarial cost methods.

Actuarial computations presented in this report under GASB Statement No. 45 are for purposes of assisting the County in fulfilling its financial accounting requirements. The computations prepared for this purpose may differ as disclosed in our report. The calculations in the enclosed report have been made on a basis consistent with our understanding of the County's funding policy and goals. The calculations in this report have been made on a basis consistent with our understanding of the County's current other post employment benefits described in Appendix A of this report, and of GASB Statement No. 45. Determinations for purposes other than meeting these requirements may be significantly different from the results contained in this report. Accordingly, additional determinations may be needed for other purposes.

Milliman's work is prepared solely for the internal business use of the Contra Costa County. To the extent that Milliman's work is not subject to disclosure under applicable public records laws, Milliman's work may not be provided to third parties without Milliman's prior written consent. Milliman does not intend to benefit or create a legal duty to any third party recipient of its work product. Milliman's consent to release its work product to any third party may be conditioned on the third party signing a Release, subject to the following exceptions:

- a) Contra Costa County may provide a copy of Milliman's work, in its entirety, to the County's professional service advisors who are subject to a duty of confidentiality and who agree to not use Milliman's work for any purpose other than to benefit the County.
- b) Contra Costa County may provide a copy of Milliman's work, in its entirety, to other governmental entities, as required by law.

No third party recipient of Milliman's work product should rely upon Milliman's work product. Such recipients should engage qualified professionals for advice appropriate to their own specific needs.

The consultants who worked on this assignment are actuaries. Milliman's advice is not intended to be a substitute for qualified legal or accounting counsel.

The signing actuary is independent of the County. We are not aware of any relationship that would impair the objectivity of our work.

On the basis of the foregoing, we hereby certify that, to the best of our knowledge and belief, the report is complete and accurate and has been prepared in accordance with generally recognized and accepted actuarial principles and practices which are consistent with the applicable Actuarial Standards of Practice of the American Academy of Actuaries. The undersigned is a member of the American Academy of Actuaries and meets the Qualification Standards of the American Academy of Actuaries to render the actuarial opinion contained herein.

Sincerely,

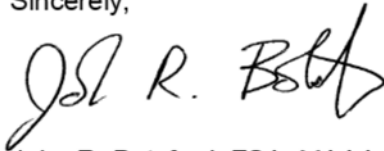
A handwritten signature in black ink, appearing to read "John R. Botsford". The signature is stylized and cursive.





John R. Botsford, FSA, MAAA  
Principal and Consulting Actuary

JRB:dyu

Section	Page
<b>I</b>	<b>MANAGEMENT SUMMARY</b>
	Introduction ..... 1
	Background..... 1
	Assumptions ..... 1
	Changes in Benefit Provisions since Last Valuation ..... 2
	Results of Study..... 2
	Variability of Results ..... 3
<b>II</b>	<b>EXHIBITS</b>
	Exhibit 1. Projected Benefit Payments ..... 4
	Exhibit 2. Liabilities and Normal Cost..... 5
	Exhibit 3. Unfunded Actuarial Accrued Liability ..... 6
	Exhibit 4. Required Financial Statement Disclosures..... 7
	Exhibit 5. Required Supplementary Information ..... 8
	Exhibit 6. Results by County’s Entities ..... 9
	Exhibit 7. Value of Subsidized Early Retiree Health Premium ..... 10
	Exhibit 8. Valuation Results – Changes from Prior Valuation ..... 11
<b>III</b>	<b>APPENDICES</b>
	Appendix A. Summary of Benefits ..... 12
	Appendix B. Actuarial Cost Method and Assumptions..... 22
	Appendix C. Changes in Actuarial Cost Method and Assumptions ..... 28
	Appendix D. Summary of Participant Data..... 29

## Introduction

Milliman, Inc. (“Milliman”) has been retained by Contra Costa County (“County”) to provide a GASB 45 actuarial valuation of its other post employment benefits (OPEB). In our valuation we:

-  Project expected payouts
-  Calculate the present value of total benefits
-  Calculate the actuarial accrued liability (present value of benefits attributable to past service)
-  Determine the Annual Required Contribution (ARC) and annual OPEB expense under GASB Statement No. 45
-  Prepare the financial statement disclosures relating to the funded status of the plan

## Background

Currently, employees who retire directly from the County may receive certain retiree health benefits if they meet certain eligibility requirements. The County may contribute an amount toward the cost of retiree health benefits for some retirees consistent with the bargaining agreement between the County and various bargaining units. Appendix A provides a detailed summary of benefits.

## Assumptions

With any valuation of future benefits, assumptions of anticipated future events are required. If actual events differ from the assumptions made, the actual cost of the County’s OPEB will vary as well.

**Discount Rate.** GASB 45 requires that the interest rate used to discount future benefit payments back to the present be based on the expected rate of return on any investments set aside to pay for these benefits. The County’s OPEB Irrevocable Trust assets are invested in the Public Agency Retirement Services’ Highmark Diversified Portfolio.

We have used a discount rate of 5.70% for this valuation. This rate represents a “blended” rate assuming the County partially funds its ARC each year. The County’s current funding policy is to fund the pay-as-you-go costs for retirees, plus \$20 million into the OPEB Trust each year. GASB 45 states that the discount rate used to calculate the present value of future benefits be derived based on the Trust’s investment policy and the County’s funding policy. Based on the Trust’s asset allocation, the average return over the next 50 years for assets invested in the Trust is expected to be 6.13%. This would be an appropriate discount rate if the County’s annual contribution were equal to the ARC. However, the County is currently funding only a portion of the ARC. Therefore, the discount rate should be a blend between the expected return on assets held in the Trust and the expected return of the County’s general fund (we have assumed a long term return of 3.50% for the County’s general fund for this purpose). For this valuation we used a blended discount rate of 5.70%.

**Health Cost Trend.** We have assumed overall health costs of the medical benefits will increase according to the health cost inflation trend derived by using the “Getzen” model developed by the Society of Actuaries. Under the Patient Protection and Affordable Care Act of 2010, including changes passed into law on December 18, 2015, a Federal excise tax will apply for high cost health benefits beginning in 2020. A margin to reflect to impact of the excise tax in future years is reflected in the assumed trend.

**Demographic Rates.** The assumptions for turnover and retirement used in this valuation are based on the latest pension actuarial report from the Contra Costa County Employees’ Retirement Association (CCCERA).

A complete summary of the actuarial assumptions is presented in Appendix B.

### Changes in Benefit Provisions since Last Valuation

Since the last valuation, benefit changes were made for several bargaining groups. Summaries of the benefit changes for affected bargaining groups (DAIA, PDOCC, Local 1230, UCOA, SEIU Local 1021, AFSCME Local 2700, Western Council of Engineers, AFSCME Local 512, CCC Defenders Association, CCC Deputy District Attorneys, Probation Peace Officers, IFPTE/AFL-CIO Local 21, and Management Classified & Exempt) are described in Appendix B. The effect of the changes on plan liabilities is shown in Exhibit 8.

### Results of Study

The valuation results are summarized in the following exhibit and use the following terms:

The **Present Value of Benefits** is the present value of projected benefits (projected claims less retiree contributions) discounted at the valuation interest rate (5.70%).

The **Actuarial Accrued Liability (AAL)** is the present value of benefits that are attributed to past service only. The portion attributed to future employee service is excluded. For retirees, this is equal to the present value of benefits. For active employees, this is equal to the present value of benefits less the present value of future normal costs.

The **Normal Cost** is that portion of the County provided benefit attributable to employee service in the current year. The Normal Cost remains level as a percentage of pay throughout the participant’s assumed working lifetime. Since retirees are not accruing any more service, their normal cost is zero.



The **Annual Required Contribution (ARC)** is equal to the Normal Cost plus an amount to amortize the unfunded AAL as a level dollar amount over a period of 30 years on a “closed” basis starting January 1, 2008. There are 22 years remaining as of January 1, 2016.

	January 1, 2016	January 1, 2014
Active Employees	8,645	8,089
Retirees	<u>6,396</u>	<u>6,206</u>
Total Participants	15,041	14,295
Present Value of Benefits	\$ 1,180,984,000	\$ 1,193,162,000
Actuarial Accrued Liability	\$ 939,053,000	\$ 923,848,000
Assets	<u>174,724,000</u>	<u>129,426,000</u>
Unfunded Actuarial Accrued Liability	\$ 764,329,000	\$ 794,422,000
Normal Cost as of valuation date	\$ 28,239,000	\$ 27,882,000
Annual Required Contribution (ARC)	\$ 89,170,000	\$ 88,538,000

### Variability of Results

The results contained in this report represent our best estimates. However, variation from these or any other estimates of future retiree medical costs is not only possible but probable. Actual future costs may vary significantly from estimates in this report.

**Exhibit 1. Projected Benefit Payments**

The table below illustrates the projected annual County costs of providing retiree health benefits. The projections only consider the closed group of existing employees and retirees.

Year	Explicit County Subsidy		Implicit Rate Subsidy		Total
	Current Retirees	Future Retirees	Current Retirees	Future Retirees	
2016	\$44,444,000	\$1,958,000	\$9,146,000	\$496,000	\$56,044,000
2017	43,540,000	5,456,000	8,956,000	1,494,000	59,446,000
2018	42,425,000	8,691,000	8,504,000	2,623,000	62,243,000
2019	41,221,000	11,560,000	8,125,000	3,683,000	64,589,000
2020	40,150,000	14,156,000	7,889,000	4,694,000	66,889,000
2021	39,922,000	16,533,000	7,496,000	5,693,000	69,644,000
2022	38,696,000	18,721,000	7,189,000	6,640,000	71,246,000
2023	37,496,000	21,020,000	6,724,000	7,786,000	73,026,000
2024	36,345,000	23,328,000	6,465,000	8,930,000	75,068,000
2025	35,063,000	25,493,000	5,933,000	10,278,000	76,767,000
2026	33,748,000	27,438,000	5,445,000	11,356,000	77,987,000
2027	32,397,000	29,305,000	4,933,000	12,474,000	79,109,000
2028	31,032,000	30,989,000	4,318,000	13,368,000	79,707,000
2029	29,608,000	32,668,000	3,586,000	14,304,000	80,166,000
2030	28,376,000	34,315,000	3,122,000	15,372,000	81,185,000
2031	26,998,000	35,632,000	2,640,000	15,879,000	81,149,000
2032	25,699,000	36,962,000	2,292,000	16,196,000	81,149,000
2033	24,521,000	38,264,000	2,074,000	16,942,000	81,801,000
2034	23,363,000	39,184,000	1,860,000	17,263,000	81,670,000
2035	22,226,000	40,177,000	1,687,000	17,127,000	81,217,000
2036	20,995,000	41,271,000	1,366,000	17,613,000	81,245,000
2037	19,818,000	42,049,000	1,128,000	18,055,000	81,050,000
2038	18,769,000	42,851,000	1,077,000	18,111,000	80,808,000
2039	17,649,000	43,325,000	982,000	18,053,000	80,009,000
2040	16,601,000	43,582,000	905,000	17,908,000	78,996,000
2041	15,503,000	43,872,000	799,000	17,806,000	77,980,000
2042	14,443,000	43,907,000	678,000	17,470,000	76,498,000
2043	13,384,000	44,072,000	501,000	17,508,000	75,465,000
2044	12,427,000	44,049,000	447,000	17,236,000	74,159,000
2045	11,432,000	43,338,000	335,000	15,901,000	71,006,000

**Exhibit 2. Liabilities and Normal Cost**

The **Present Value of Benefits** is the actuarial present value of benefits expected to be paid for all eligible retirees and covered employees.

The **Actuarial Accrued Liability (AAL)** is the present value of benefits that are attributed to past service only. The portion attributed to future employee service is excluded. For retirees, this is equal to the present value of benefits. For active employees, this is equal to the present value of benefits less the present value of future normal costs

The **Normal Cost** is that portion of the County provided benefit attributable to employee service in the current year. The Normal Cost remains level as a percentage of pay throughout the participant's assumed working lifetime. Since retirees are not accruing any more service, their normal cost is zero.

	January 1, 2016	January 1, 2014
<b>Present Value of Benefits</b>		
Actives	\$ 613,108,000	\$ 625,243,000
Retirees	<u>567,876,000</u>	<u>567,919,000</u>
Total	\$ 1,180,984,000	\$ 1,193,162,000
<b>Actuarial Accrued Liability</b>		
Actives	\$ 371,177,000	\$ 355,929,000
Retirees	<u>567,876,000</u>	<u>567,919,000</u>
Total	\$ 939,053,000	\$ 923,848,000
<b>Normal Cost as of valuation date</b>	\$ 28,239,000	\$ 27,882,000

**Exhibit 3. Unfunded Actuarial Accrued Liability**

The Unfunded Actuarial Accrued Liability (UAAL) is the actuarial liability offset by any assets set-aside in a trust to fund future retiree health benefits. The amortization of UAAL shown in the exhibit below is based on a level dollar amount over a period of 30 years on a closed basis from January 1, 2008. There are 22 years remaining as of the valuation date of January 1, 2016.

	January 1, 2016	January 1, 2014
<b>Unfunded Actuarial Accrued Liability (UAAL)</b>		
Actuarial Accrued Liability	\$ 939,053,000	\$ 923,848,000
Reserve Fund	<u>174,724,000</u>	<u>129,426,000</u>
Unfunded Actuarial Accrued Liability	\$ 764,329,000	\$ 794,422,000
Funded Percentage	18.6%	14.0%
<b>Amortization of UAAL for ARC</b>		
UAAL	\$ 764,329,000	\$ 794,422,000
Amortization Period	22 years	24 years
Level Dollar Amortization Factor	13.0668	13.6416
Amortization Amount – January 1	\$ 58,494,000	\$ 58,235,000
Interest to June 30	<u>1,644,000</u>	<u>1,637,000</u>
Amortization Amount – June 30	\$ 60,138,000	\$ 59,872,000

**Exhibit 4. Required Financial Statement Disclosures**

The following table shows the calculation of the Annual Required Contribution and Net OPEB Obligation.

	June 30, 2016	June 30, 2015
<b>Determination of Annual Required Contribution</b>		
Normal Cost at Fiscal Year End	\$ 29,032,000	
Amortization of UAAL	<u>60,138,000</u>	
Annual Required Contribution (ARC)	\$ 89,170,000	
<b>Determination of Net OPEB Obligation</b>		
Annual Required Contribution	\$ 89,170,000	\$ 88,538,000
Interest on Prior Year Net OPEB Obligation	28,203,000	28,063,000
Adjustment to ARC	<u>(37,867,000)</u>	<u>(36,845,000)</u>
Annual OPEB Cost	\$ 79,506,000	\$ 79,756,000
County Contributions Made	<u>(76,279,000)</u>	<u>(77,288,000)</u>
Increase in Net OPEB Obligation	\$ 3,227,000	\$ 2,468,000
Net OPEB Obligation – Beginning of Year	\$ 494,795,000	\$ 492,327,000
Net OPEB Obligation – End of Year	\$ 498,022,000	\$ 494,795,000

The following table shows the annual OPEB cost and net OPEB obligation for the prior years.

Fiscal Year Ended	Annual OPEB Cost	Percentage Of OPEB Cost Contributed	Net OPEB Obligation
06/30/2014	\$ 80,575,000	95.1%	\$ 492,327,000
06/30/2015	\$ 79,756,000	96.9%	\$ 494,795,000
06/30/2016	\$ 79,506,000	95.9%	\$ 498,022,000

**Funded Status and Funding Progress.** As of January 1, 2016, the most recent actuarial valuation date, the County's OPEB was 18.6% funded. The actuarial accrued liability for benefits was \$939 million, and the actuarial value of assets was \$175 million, resulting in an unfunded actuarial accrued liability of \$764 million.

**Exhibit 5. Required Supplementary Information**

The following table shows a schedule of Funding Progress required under GASB 45.

(Figures in millions)

Actuarial Valuation Date	Actuarial Value of Assets	AAL	UAAL	Funded Ratio	Covered Payroll	UAAL as % of Covered Payroll
01/01/2012*	\$ 65	\$ 1,034	\$ 969	6.3%	\$ 624	155.3%
01/01/2014	129	924	794	14.0%	614	129.4%
01/01/2016	175	939	764	18.6%	696	109.8%

\* Figures taken from Contra Costa County's CAFR as of June 30, 2013. Due to rounding figures may not add up.

**Exhibit 6. Results by County's Entities**

The following table shows the breakdown of valuation results by various entities within the County.

ENTITY	AAL	NC <sup>1</sup>	ARC <sup>2</sup>
Safety Non-Fire	\$ 221,891,000	\$ 6,456,000	\$ 20,666,000
CCC Fire	104,517,000	2,548,000	9,241,000
Hospital	180,151,000	7,355,000	18,892,000
CCHP	8,231,000	410,000	937,000
Airport	2,076,000	20,000	153,000
CCC Retirement System <sup>3</sup>	1,770,000	0	113,000
All Other CCC Departments	<u>420,417,000</u>	<u>12,243,000</u>	<u>39,168,000</u>
Total	\$ 939,053,000	\$ 29,032,000	\$ 89,170,000

<sup>1.</sup> Normal Cost includes interest to June 30, 2016.

<sup>2.</sup> We allocated the assets used to calculate the Annual Required Contribution for each entity based on their AAL relative to the total AAL.

<sup>3.</sup> As of January 1, 2015, CCC Retirement System became its own independent entity. The AAL shown is for CCC Retirement System employees who retired as County employees before January 1.

**Exhibit 7. Value of Subsidized Early Retiree Health Premium**

Currently, the County charges early retirees not yet eligible for Medicare a health premium based on the claims experience of both actives and retirees. Since health claim costs generally increase with age, retiree health premiums would be significantly higher if they were determined without regard to active claims experience. GASB 45 requires that the portion of age-adjusted expected retiree health claim costs that exceed the carrier premiums (known as an “implicit rate subsidy”) be recognized as a liability for accounting purposes. Implicit rate subsidies for spouses of retirees must also be valued in determining the ARC under GASB 45. The following table shows the County’s GASB 45 liability broken down by the County’s actual payments toward retiree premiums and the “subsidized” value of retiree health premiums.

	County’s Payment	Implicit Rate Subsidy	Total
<b>Present Value of Benefits</b>			
Active Employees	\$ 451,815,000	\$ 161,293,000	\$ 613,108,000
Retirees	<u>490,608,000</u>	<u>77,268,000</u>	<u>567,876,000</u>
Total	\$ 942,423,000	\$ 238,561,000	\$ 1,180,984,000
<b>Actuarial Accrued Liability</b>			
Active Employees	\$ 282,564,000	\$ 88,613,000	\$ 371,177,000
Retirees	<u>490,608,000</u>	<u>77,268,000</u>	<u>567,876,000</u>
Total	\$ 773,172,000	\$ 165,881,000	\$ 939,053,000
Normal Cost as of Valuation Date	\$ 20,910,000	\$ 7,329,000	\$ 28,239,000



**Exhibit 8. Valuation Results – Changes from Prior Valuation**

The following exhibit shows changes of Actuarial Accrued Liability (AAL) from the prior valuation:

	In Millions
Actuarial Accrued Liability (AAL) as of January 1, 2014	924
Increase due to benefit accrued from January 1, 2014 to December 31, 2015	\$ 57
Decrease due to expected benefit payments made from January 1, 2014 to December 31, 2015	(114)
Increase due to decrease in the discount period from January 1, 2014 to December 31, 2015	105
Decrease due to benefit changes for DAIA, L1230, PDOCC, and UCOA since last valuation	(33)
Decrease due to health cost increases less than expected	(26)
Increase due to assumption changes <sup>1</sup>	4
Increase due to change in Actuarial Cost Method from PUC to Individual Entry Age Normal <sup>2</sup>	11
Increase due to plan changes to current retirees with benefit frozen at the 2011 level	8
Increases due to other changes <sup>3</sup>	<u>3</u>
Total change in Actuarial Accrued Liability	\$ 15
Actuarial Accrued Liability (AAL) as of January 1, 2016	\$ 939

1. *We updated the coverage election assumptions and health cost inflation assumptions. See Appendix C for a summary of the changes.*
2. *This change was made to align the actuarial cost method with the method prescribed under GASB 75.*
3. *Includes changes in census data and other experience.*

**Appendix A. Summary of Benefits**

The following description of retiree health benefits is intended to be only a brief summary and is not complete information.

**Eligibility**

Currently, employees may receive retiree health benefits if they retire from the County, are receiving a pension from CCCERA, and meet certain eligibility requirements as follows:

General employees - age 50 with 10 years of pension service or age 70 with a vested pension, or after 30 years of pension service with no age requirement.

Safety employees - age 50 with 10 years of pension service or age 70 with a vested pension, or after 20 years of pension service with no age requirement.

Employees hired after December 31, 2006 and represented by the following bargaining groups (AFSCME, California Nurses Association, Deputy District Attorneys' Association, Public Defenders Association, IFPTE, Western Council of Engineers, SEIU, PEU, Probation Peace Officers Association, and Unrepresented) also must have 15 years of County service.

Employees hired on or after October 1, 2005, and represented by the Physicians' and Dentists' Organization also must have 15 years of County service.

**Health Benefits**

Currently, eligible retirees and their dependents are covered either under the Contra Costa Health Plans, Health Net plans, Kaiser plans, or health plans sponsored by CalPERS (PEMHCA). Coverage may be provided for a retiree and surviving spouse as long as retiree and surviving spouse monthly premium contributions are paid. The County may pay a subsidy toward eligible retirees' monthly medical and dental premiums. This subsidy may vary by bargaining unit and date of hire as described in this appendix. Employees hired on or after dates described in the table below and represented by the following bargaining groups must pay the entire cost of premiums to maintain coverage.

Bargaining Unit Name	Hire Date on or after which eligible retirees must pay entire cost of premiums
IFPTE, Unrepresented	January 1, 2009
AFSCME, Western Council of Engineers, SEIU, and PEU	January 1, 2010
Deputy District Attorneys Association	December 14, 2010
Probation Peace Officers Association of CCC	January 1, 2011
CCC Public Defenders Association	March 1, 2011

All surviving spouses must pay the entire cost of premiums to maintain coverage, with the exception of the following bargaining groups for whom the surviving spouse receives the same County subsidy as the retiree (covered by CalPERS health plans): Sheriff (A8), Fire Chief (BD), Sworn Exec. Mgmt. (BS), Fire Management (HA), Deputy Sheriffs (V#, VH, VN), Fire Suppression and Prevention (4N), Fire District Safety Management (BF), and D.A. Investigators (XJ).

Bargaining Units V#, VH, VN, F8 and FW

Currently, for eligible retirees from the bargaining units listed in the table below, the County will contribute toward the cost of monthly premiums (medical and dental) an amount equal to the actual dollar monthly premium amount paid by the County as of November 30, 2013, at each coverage level, plus 50% of the actual premium increase for 2014 and all future years.

Retirees who elected dental coverage without health coverage will pay one cent (\$0.01) per month for 2013, plus 50% of the actual premium increase for 2014 and all future years.

Bargaining Unit Code	Bargaining Unit Name	General / Safety
F8	Unrep Classified & Exempt-Othr	General
FW	Unrep CI & Ex-Sworn Peace Offc	Safety
V#	Sheriff's Sworn Mgmt Unit	Safety
VH	Deputy Sheriff's Unit-Sworn	Safety
VN	Deputy Sheriff's Unit-NonSworn	General

For employees hired between January 2, 2007, and September 30, 2011, and represented by the Deputy Sheriffs' Association, the County subsidy is subject to a vesting schedule as shown in the table below.

Credited Years of Service	Percentage of Employer Contribution
10	50
11	55
12	60
13	65
14	70
15	75
16	80
17	85
18	90
19	95
20 or more	100

*Bargaining Unit HA – Fire Management*

Currently, for eligible Fire Management retirees represented by United Chief Officers Association (UCOA) with bargaining unit code HA, the County will subsidize an amount equal to 80% of the CalPERS Kaiser Bay Area premium at each coverage level (employee only, employee + one, employee + two or more) for any region in which the retiree resides, but the County's subsidy will not exceed the total premium of a lower cost plan.

*Health Premium Subsidy on or after December 1, 2016:* For the plan year that begins on January 1, 2017 and each calendar year thereafter, the maximum monthly premium subsidy the District will pay for each health plan is equal to the actual dollar monthly premium subsidy that is paid by the District for that plan as of November 30, 2016. In addition, if there is an increase in the monthly premium charged by a health plan for 2017, the District and the employee will each pay fifty percent (50%) of that increase. For each plan year thereafter, and for each plan, the District and the employee will each pay fifty (50%) of the monthly premium increase above the 2016 plan premiums.

*Dental Subsidy for Retirees with Medical Coverage:* For eligible retirees from bargaining unit HA enrolled in both a medical and dental plan, for the plan year that begins on January 1, 2016, the District will pay a monthly premium subsidy for each dental plan that is equal to the actual dollar monthly premium subsidy that is paid by the District as of November 30, 2015. In addition, if there is an increase in the monthly premium charged by a dental plan for 2016, the District and the employee will each pay fifty percent (50%) of that increase. For each plan year thereafter, the District and the employee will each pay fifty percent (50%) of the monthly premium increase above the 2015 plan premium.

*Dental Subsidy for Retirees without Medical Coverage:* For eligible retirees from bargaining unit HA enrolled in a dental plan only without health coverage, beginning on January 1, 2016, the District will pay a monthly dental premium subsidy for each dental plan that is equal to the actual dollar monthly premium subsidy that is paid by the District for 2015. If there is an increase in the premium charged by a dental plan for 2016, the District and the employee will each pay fifty percent (50%) of the increase. For each plan year thereafter, the District and the employee will each pay fifty percent (50%) of the premium increase that is above the 2015 plan premium.

Bargaining Unit XJ – D.A. Investigators

*Health Premium Subsidy:* For the plan year that begins on January 1, 2015, the County will pay the following monthly medical premium subsidy:

Coverage	Monthly Premium Subsidy
Employee/Retiree/Survivor Only	\$ 608.87
Employee/Retiree/Survivor & One Dependent	1,217.74
Employee/Retiree/Survivor & Two or more Dependents	1,583.07

In addition, if there is an increase in the monthly premium charged by a health plan for 2015 that exceeds the above stated amounts, the County and the retiree will each pay fifty percent (50%) of that increase. For 2016, the County premium subsidy varies by plan depending on the actual premium increase that occurred for each plan. For each calendar year thereafter, the County and the retiree will each pay fifty percent (50%) of any premium increase for each health plan.

*Dental Premium Subsidy:* For the plan year that begins on January 1, 2015, the County will pay the following monthly dental premium subsidy:

Coverage	With Health		Without Health	
	Delta Dental	DeltaCare (PMI)	Delta Dental	DeltaCare (PMI)
Single	\$ 32.69	\$ 22.30	\$ 42.44	\$ 28.91
Family	73.64	48.19	95.62	61.49

In addition, if there is an increase in the monthly premium charged by a health plan for 2015 that exceeds the above stated amounts, the County and the retiree will each pay fifty percent (50%) of that increase. For each calendar year thereafter, the County and the retiree will each pay fifty percent (50%) of any premium increase for each dental plan.

Bargaining Unit 4N - Fire Suppression and Prevention

*Health Premium Subsidy:* For 2016 and each calendar year thereafter, the prior year’s District subsidy for each medical plan and rate tier will increase by 50% of the actual premium increase in the medical plan and rate tier in which the member is enrolled.

*Dental Premium Subsidy:* For eligible retirees from bargaining unit 4N enrolled in both a medical and dental plan, the District will pay a subsidy equal to 50% of the cost of monthly dental premiums in 2016 and later. For retirees enrolled only in a dental plan, retirees are required to pay \$0.01 per month for dental coverage. For 2016 and later, the required monthly contribution from retirees would increase each year by 50% of the dental premium increase.

Bargaining Units 1P and 1R – Physicians & Dentists

Beginning on January 1, 2015, and for each calendar year thereafter, the County will pay a monthly dollar premium subsidy for each health and dental plan (County Premium Subsidy) as defined for each plan in the table below.

Health Plan	Frozen Subsidy Amount
<u>Contra Costa Health Plan A</u>	
Retiree on Basic Plan	\$ 600.51
Retiree & 1 or more dependents on Basic Plan	1,430.76
Retiree on Medicare COB Plan	279.22
Retiree & Spouse on Medicare COB Plan	558.44
Family, 1 on Medicare COB Plan, and 1 or more on Basic Plan	1,234.35
<u>Contra Costa Health Plan B</u>	
Retiree on Basic Plan	\$ 611.34
Retiree & 1 or more dependents on Basic Plan	1,452.65
Retiree on Medicare COB Plan	287.59
Retiree & Spouse on Medicare COB Plan	575.18
Family, 1 on Medicare COB Plan, and 1 or more on Basic Plan	1,271.37
<u>Kaiser Permanente</u>	
Retiree on Basic Plan	\$ 614.78
Retiree & 1 or more dependents on Basic Plan	1,432.42
Retiree on Medicare Senior Advantage Plan	295.00
Retiree & 1 dependent on Medicare Senior Advantage Plan	796.70
Retiree on Medicare Sr. Adv. Plan, and 1 or more dependents on Basic Plan	1,158.55
<u>Health Net HMO</u>	
Retiree on Basic Plan	\$ 853.92
Retiree & 1 or more dependents on Basic Plan	2,094.74
Retiree on Medicare Seniority Plus Plan	514.27
Retiree & 1 dependent on Medicare Seniority Plus Plan	1,028.55
Retiree on Medicare Sr. Plus Plan, and 1 or more dependents on Basic Plan	1,370.24
<u>Health Net Medicare COB</u>	
Retiree only	\$ 563.32
Retiree & spouse	1,126.65
<u>Health Net CA &amp; Nat'l PPO – Basic Plan A</u>	
Retiree on PPO	\$ 753.81
Retiree & 1 or more dependents on PPO Basic Plan	1,790.70
Retiree on PPO Medicare Plan with Medicare Part A & B	618.43
Retiree & 1 or more dependents on PPO Medicare Plan with Medicare Part A & B	1,236.73

The amount of the County subsidy that is paid for employees and eligible family members for these plans will thereafter be a set dollar amount and will not be a percentage of the premium charged by the health or dental plan. Retirees must pay for 100% of any premium increases after 2015.

Bargaining Unit L3 – Registered Nurses Unit

Currently, for eligible retirees from the bargaining unit L3, the County subsidizes a percentage of monthly premiums that varies depending on the medical and dental plan elected. Retirees retired on or before 06/30/2012 and age 65 on or before 10/31/2012 also receive reimbursement of their Medicare Part B premiums as long as the total County subsidy does not exceed 100% of the medical plan premium.

Retirees receive the following County subsidy based on the medical plan elected:

Medical Plan	County Subsidy % (Medical)	County Subsidy % (Dental)
<u>Contra Costa Health Plan A and B</u>		
Without Dental	98%	0%
With Delta Dental	98%	98%
With PMI Delta Dental	98%	98%
<u>Kaiser, Health Net HMO</u>		
Without Dental	80%	0%
With Delta Dental	80%	78%
With PMI Delta Dental	80%	78%
<u>Health Net PPO</u>		
Without Dental	54%*	0%
With Delta Dental	54%*	78%
With PMI Delta Dental	54%*	78%
Dental Only	0%	All but \$0.01 / month
 <i>Approximately 54% for 2016. Future increases are split evenly between the County and the retiree.</i>		

All other Bargaining Units - County Subsidy Frozen at the 2011 Level

Currently, eligible retirees from the following bargaining units listed may receive County subsidies towards medical and dental premiums. The subsidies are frozen at the 2011 levels shown in the tables on pages 19-20. There are no future increases to these subsidy amounts except as defined on page 19 for certain retirees who retired before January 1, 2016.

Bargaining Unit Code	Bargaining Unit Name	General / Safety	Bargaining Unit Code	Bargaining Unit Name	General / Safety
1X	Phys & Dnts & Optometrist Unit	General	JF	CCC Defenders/Investigators	General
25	Social Services Unit	General	K2	Property Appraisers Unit	General
51	Professional Engineers Unit	General	K5	Court Professional Svcs Unit	General
99	DEFAULT BARGAINING UNIT	General	K6	Supervisory Clerical Unit	General
2D	Community Aide Unit	General	KK	Income Maintenance Program Unit	General
2I	Service Line Supervisors Unit	General	KL	Engineering Technician Unit	General
2R	Superior Court Reporters-Ex	General	KM	Sheriff's Non-Sworn Mgmt Unit	General
3A	Superior Court Clerical Unit	General	KU	Probation Supervisors Unit	Safety
3B	Superior Court Barg Unit-Loc1	General	KZ	Social Svcs Staff Special Unit	General
3G	Deputy Clerks Unit	General	MA	District Attorneys' Unit	General
3R	General Clerical Unit	General	N2	Property Appraisers Unit	General
A8	Elected Department Heads	General	PP	Probation Unit of CCC	Safety
AJ	Elected Superior Court Judges	General	QA	Agriculture & Animal Ctrl Unit	General
AM	Elected Municipal Court Judges	General	QB	LVN/Aide Unit	General
AS	Elected Board of Supvs Members	General	QC	Fam/Chld Svs Site Supv Unit	General
B8	Mgmt Classes-Classified & Exem	General	QE	Building Trades Unit	General
BA		General	QF	Deputy Public Defender Unit/At	General
BC	Superior Court Exempt Mgmt Gen	General	QG	Deputy Public Defender Unit-In	General
BD	Mgmt Classified & Ex Dept Head	General	QH	Family and Children Services	General
BF	Fire District (MS) Safety Mgmt	Safety	QM	Engineering Unit	General
BH	Superior Ct Exempt Mgmt-DH	General	QP		General
BJ	Sup Ct Judicial Ofcrs Ex-Mgmt	General	QS	General Services & Mtce Unit	General
BS	Sheriff's Sworn Executive Mgmt	Safety	QT	Health Services Unit	General
C8	Management Project-Other	General	QV	Investigative Unit	General
CH	CS Head Start Mgmt-Project	General	QW	Legal & Court Clerk Unit	General
D8	Unrepresented Proj Class-Other	General	QX	Library Unit	General
F8	Unrep Classified & Exempt-Other	General	QY	Probation Unit	General
FC	Unrep Superior Ct Clerical Exempt	General	S2		General
FD	Unrep Superior Ct Other Exempt	General	Z1	Supervisory Project	General
FM	Unrep Muni Ct Reporter-Exempt	General	Z2	Non-Supervisory Project	General
FR	Unrep Superior Ct Reprts-Exempt	General	ZA	Supervisory Management	General
FS	Unrep Cl & Ex Student Workers	General	ZB	Non-Supervisory Management	General
FX	Unrep Exempt Medical Staff	General	ZL	Supervisory Nurse	General
JD	CCC Defenders/Attorneys	General	ZN	Non-Supervisory Nurse	General



Health Insurance Premium Rates (non-PEMHCA)

The following table shows monthly retiree health insurance premiums for the 2016 calendar year for coverage under various health plans sponsored by Contra Costa County, and the County's subsidies as frozen at the 2011 level.

Effective January 1, 2017, the medical premium tier structure is expected to change from two tiers (retiree only, retiree plus one or more dependents) to three tiers (retiree only, retiree plus one dependent, and retiree plus two or more dependents) for Non-Medicare Retirees. Effective when the three tier system goes into effect for Non-Medicare retirees, the County's premium caps established in 2011 will continue to apply for single and two party coverage: "retiree only" cap for single coverage and retiree plus one or more dependent cap applies for the retiree plus one dependent tier. For certain retirees who retired before January 1, 2016, the County will increase the monthly medical plan premium subsidies for the new non-Medicare Retiree plus Two or More Dependents tier (defined as Tier III) by \$150. For retirees retiring on or after January 1, 2016, the County subsidy for Tier III will be the same as for Tier II as shown in the table below.

Effective January 1, 2021 for certain retirees who retired before January 1, 2016, the amount of the County monthly medical plan premium subsidy will increase by \$25 for the Medicare retiree only tier and for the retiree plus one or more dependents on Medicare tier.

Medical Plan	County's Subsidy (Frozen in 2011)	2016 Premium Rate	County's Subsidy for 2016	Retiree's Share for 2016
<u>Contra Costa Health Plan A</u>				
Retiree on Basic Plan	\$ 509.92	\$ 709.06	\$ 509.92	\$ 199.14
Retiree & 1 or more dependents on Basic Plan	1,214.90	1,689.37	1,214.90	474.47
Retiree on Medicare Coordination of Benefits (COB) Plan	420.27	326.13	326.12	0.01
Retiree & 1 or more dependents on Medicare COB Plan	1,035.60	652.26	652.25	0.01
<u>Contra Costa Health Plan B</u>				
Retiree on Basic Plan	528.50	786.01	528.50	257.51
Retiree & 1 or more dependents on Basic Plan	1,255.79	1,867.68	1,255.79	611.89
Retiree on Medicare COB Plan	444.63	335.91	335.90	0.01
Retiree & 1 or more dependents on Medicare COB Plan	1,088.06	671.82	671.81	0.01
<u>Kaiser Permanente – Plan A</u>				
Retiree on Basic Plan	478.91	819.43	478.91	340.52
Retiree & 1 or more dependents on Basic Plan	1,115.84	1,910.33	1,115.84	794.49
Retiree on Medicare COB Plan	263.94	296.67	263.94	32.73
Retiree & 1 dependent on Medicare COB Plan	712.79	802.02	712.79	89.23
Retiree & 2 dependents on Medicare COB Plan	1,161.65	1,305.13	1,161.65	143.48
<u>Kaiser Permanente – Plan B</u>				
Retiree on Basic Plan	478.91	656.63	478.91	177.72
Retiree & 1 or more dependents on Basic Plan	1,115.84	1,529.95	1,115.84	414.11
Retiree on Medicare COB Plan	263.94	225.18	225.17	0.01
Retiree & 1 dependent on Medicare COB Plan	712.79	608.00	607.99	0.01
Retiree & 2 dependents on Medicare COB Plan	1,161.65	988.89	988.88	0.01

Health Insurance Premium Rates (continued)

Medical Plan	County's Subsidy (Frozen in 2011)	2016 Premium Rate	County's Subsidy for 2016	Retiree's Share for 2016
<u>Health Net HMO – Plan A</u>				
Retiree on Basic Plan	627.79	1,294.30	627.79	666.51
Retiree & 1 or more dependents on Basic Plan	1,540.02	3,175.02	1,540.02	1,635.00
Retiree on Medicare Seniority Plus Plan	409.69	545.59	409.69	135.90
Retiree & 1 dependent on Medicare Seniority Plus Plan	819.38	1,091.18	819.38	271.80
Retiree & 2 dependents on Medicare Seniority Plus Plan	1,229.07	1,636.76	1,229.07	407.69
<u>Health Net HMO – Plan B</u>				
Retiree on Basic Plan	627.79	900.03	627.79	272.24
Retiree & 1 or more dependents on Basic Plan	1,540.02	2,207.86	1,540.02	667.84
Retiree on Medicare Seniority Plus Plan	409.69	458.02	409.69	48.33
Retiree & 1 dependent on Medicare Seniority Plus Plan	819.38	916.04	819.38	96.66
Retiree & 2 dependents on Medicare Seniority Plus Plan	1,229.07	1,374.06	1,229.07	144.99
<u>Health Net Medicare COB</u>				
Retiree only	\$ 467.13	\$ 659.04	\$ 467.13	\$ 191.91
Retiree & spouse	934.29	1,318.08	934.29	383.79
<u>Health Net CA &amp; Nat'l PPO – Basic Plan A</u>				
Retiree on PPO	604.60	1,699.52	604.60	1,094.92
Retiree & 1 or more dependents on PPO Basic Plan	1,436.25	4,037.34	1,436.25	2,601.09
Retiree on PPO Medicare Plan with Medicare Part A & B	563.17	987.65	563.17	424.48
Retiree & 1 or more dependents on PPO Medicare Plan with Medicare Part A & B	1,126.24	1,975.31	1,126.24	849.07
<u>Health Net CA &amp; Nat'l PPO – Basic Plan B</u>				
Retiree on PPO	604.60	1,529.99	604.60	925.39
Retiree & 1 or more dependents on PPO Basic Plan	1,436.25	3,634.58	1,436.25	2,198.33
Retiree on PPO Medicare Plan with Medicare Part A & B	563.17	897.02	563.17	333.85
Retiree & 1 or more dependents on PPO Medicare Plan with Medicare Part A & B	1,126.24	1,794.04	1,126.24	667.80

PEMHCA Health Plan Premium Rates

Eligible retirees from the bargaining units 4N, A8, B8, BD, BF, BS, F8, FW, HA, V#, VH, VN, and XJ can choose to enroll in health plans sponsored by CalPERS based on their residence region (Bay Area, Sacramento, Los Angeles, Northern California, Southern California and Out of State of California). The following table shows the monthly Bay Area retiree health insurance premiums for the 2016 calendar year:

	<i>Monthly Premium Rates – 2016</i>					
	Single		2-Party		Family	
	Under 65	Over 65	Under 65	Over 65	Under 65	Over 65
Blue Shield	\$ 1,016.18	n/a	\$ 2,032.36	n/a	\$ 2,642.07	n/a
Blue Shield NetValue	1,033.86	n/a	2,067.72	n/a	2,688.04	n/a
Kaiser	746.47	297.23	1,492.94	594.46	1,940.82	891.69
PERSCare	889.27	408.04	1,778.54	816.08	2,312.10	1,224.12
PERS Choice	798.36	366.38	1,596.72	732.76	2,075.74	1,099.14
PERS Select	730.07	366.38	1,460.14	732.76	1,898.18	1,099.14
Anthem HMO Select	721.79	n/a	1,443.58	n/a	1,876.65	n/a
Anthem HMO Traditional	855.42	n/a	1,710.84	n/a	2,224.09	n/a
Health Net SMARTCare	808.44	n/a	1,616.88	n/a	2,101.94	n/a
United Healthcare	955.44	320.98	1,910.88	641.96	2,484.14	962.94
PORAC	699.00	442.00	1,399.00	881.00	1,789.00	1,408.00
CCHP	837.46	716.08	1,674.92	1,432.16	2,177.40	2,148.24

Effective January 1, 2016, CalPERS no longer offer Medicare Advantage plan coverage through Anthem Blue Shield, and added HealthNet as a new carrier to offer non-Medicare coverage.

Dental Plan Premiums

The following table shows monthly retiree dental insurance premiums for the 2016 calendar year. County subsidies vary based on retiree’s medical plan enrollment election and bargaining unit upon retirement.

Plan	Monthly Premiums
<b>Delta Dental - \$1,800 Annual Maximum</b>	
Retiree	\$ 44.27
Family	100.00
<b>Delta Dental - \$1,600 Annual Maximum</b>	
Retiree	\$ 42.45
Family	95.63
<b>Delta Care (PMI)</b>	
Retiree	\$ 29.06
Family	62.81

**Appendix B. Actuarial Cost Method and Assumptions**

**Actuarial Cost Method** The actuarial cost method used for determining the benefit obligations is the individual Entry Age Normal Cost Method. Under the principles of this method, the actuarial present value of the projected benefits of each individual included in the valuation is allocated as a level percentage of expected salary for each year of employment between entry age (defined as age at hire) and assumed exit.

The portion of this actuarial present value allocated to a valuation year is called the normal cost. The portion of this actuarial present value not provided for at a valuation date by the sum of (a) the actuarial value of the assets, and (b) the actuarial present value of future normal costs is called the Unfunded Actuarial Accrued Liability (UAAL).

The Actuarial Value of Assets is equal to the market value of assets as of the valuation date. In determining the Annual Required Contribution, the Unfunded AAL is amortized as a level dollar amount over 30 years on a “closed” basis. There are 22 years remaining in the amortization period as of January 1, 2016. The actuarial assumptions are summarized below.

**Economic Assumptions**

*Discount Rate (Liabilities)* 5.70%

We have used a discount rate of 5.70% in this valuation to reflect the County’s current policy of partially funding its OPEB liabilities. This rate is derived based on the fund’s investment policy, level of partial funding, and includes a 2.50% long-term inflation assumption. County OPEB Irrevocable Trust assets are invested in the Public Agency Retirement Services’ Highmark Portfolio. Based on the portfolio’s target allocation (shown below), the average return of Trust assets over the next 50 years is expected to be 6.13%, which would be an appropriate discount rate if the County’s annual contribution is equal to the ARC. If the County were to elect not to fund any amount to a Trust, the discount rate would be based on the expected return of the County’s general fund (we have assumed a long term return of 3.50% for the County’s general fund). Since the County is partially funding the Trust with a contribution of \$20 million per year, we used a blended discount rate of 5.70%. This is the same discount rate used in the January 1, 2014 actuarial valuation.

Asset Class	Expected 1-Year Nominal Return	Targeted Asset Allocation
Domestic Equity Large Cap	7.63%	17.0%
Domestic Equity Mid Cap	8.21%	6.0%
Domestic Equity Small Cap	8.81%	8.0%
U.S. Fixed Income	5.00%	38.0%
International	8.60%	9.0%
Global Equity (Developed)	8.21%	7.0%
Real Estate	7.71%	4.0%
Cash	3.27%	1.0%
Alternatives	4.57%	10.0%
<b>Expected Geometric Median Annual Return (50 years)</b>		<b>6.13%</b>

*Assumed Salary Increases (Applied to Individual Entry Age Normal Cost Method)*

The assumed annual rates of compensation increases used for the EAN actuarial cost method are the same as the assumption used in the December 31, 2014 CCCERA Actuarial Valuation.

Years of Service	General	Safety
Less than 1	13.50%	14.00%
1	10.50%	10.50%
2	8.75%	9.25%
3	7.25%	8.00%
4	6.25%	6.25%
5	5.50%	5.00%
6	5.25%	4.75%
7	5.00%	4.75%
8 or more	4.75%	4.75%

**Demographic Assumptions**

Below is a summary of the assumed rates for mortality, retirement, disability and withdrawal, which are consistent with assumptions used in the December 31, 2014 CCCERA Actuarial Valuation. These assumptions were adopted by CCCERA in connection with a study of experience during 2010-2012.

*Pre / Post Retirement Mortality*

**Healthy:** For General Members: RP-2000 Combined Healthy Mortality Table projected to 2030 with Scale AA, set back one year.

For Safety Members: RP-2000 Combined Healthy Mortality Table projected to 2030 with Scale AA, set back two years.

**Disabled:** For General Members: RP-2000 Combined Healthy Mortality Table projected to 2030 with Scale AA, set forward six years for males and set forward seven years for females.

For Safety Members: RP-2000 Combined Healthy Mortality Table projected to 2030 with Scale AA, set forward three years.

**Beneficiaries:** Beneficiaries are assumed to have the same mortality as a General Member of the opposite sex who had taken a service (non-disability) retirement.

*Disability*

Age	General Tier 3 / PEPRA	Safety (All Tiers)
20	0.01%	0.02%
25	0.02%	0.22%
30	0.03%	0.42%
35	0.05%	0.56%
40	0.08%	0.66%
45	0.13%	0.94%
50	0.17%	2.54%

*Retirement* – For this valuation, we have applied the Tier 3 rates for all General employees and Tier A rates for all Safety employees since nearly all current employees are in these two pension tiers, with the exception of those who were hired after January 1, 2013 as the PEPRA tiers.

Age	General Tier 3	General PEPRA	Safety Tier A	Safety PEPRA
45	0%	0%	2%	0%
46	0%	0%	2%	0%
47	0%	0%	7%	0%
48	0%	0%	7%	0%
49	0%	0%	20%	0%
50	4%	0%	25%	5%
51	3%	0%	25%	4%
52	3%	2%	25%	4%
53	5%	3%	25%	5%
54	5%	3%	25%	5%
55	10%	5%	30%	6%
56	10%	5%	25%	8%
57	10%	6%	25%	12%
58	12%	8%	35%	18%
59	12%	9%	35%	20%
60	15%	10%	40%	20%
61	20%	14%	40%	20%
62	27%	21%	40%	20%
63	27%	21%	40%	20%
64	30%	21%	40%	100%
65	40%	27%	100%	100%
66 – 69	40%	33%	100%	100%
70 – 74	40%	50%	100%	100%
75	100%	100%	100%	100%

*Withdrawal* – Sample probabilities of terminating employment with the County are shown below for selected years of County service.

Years of Service	General	Safety
Less than 1	13.50%	11.50%
1	9.00%	6.50%
2	9.00%	5.00%
3	6.00%	4.00%
4	4.50%	3.50%
5	4.00%	3.00%
10	2.75%	1.90%
15	2.10%	1.40%
20 or more	2.00%	1.00%

**Coverage Election Assumptions**

*Retiree Coverage* – We have assumed 90% of new retirees hired before the exclusion date stated in Appendix A will elect medical and dental coverage at retirement. For employees hired after the exclusion date stated in Appendix A, we assumed 50% will elect to enroll in the health plans without any County subsidy.

*Spouse Coverage* – We have assumed 50% of new General retirees and 60% of new Safety retirees electing coverage will elect spouse medical and dental coverage at retirement.

*Spouse Age* – Female spouses are assumed to be three years younger than male spouses.

*Dependent Coverage* – We have assumed 30% of retirees with no spouse coverage will elect coverage for a dependent child until age 65 and 50% of retirees with spouse coverage will elect coverage for a dependent child until age 65.

*Health Plan Election* – We have assumed that new retirees will remain enrolled in the same plan they were enrolled in as actives. For actives who waived coverage, we have assumed that they will elect Kaiser plan coverage. For retirees enrolled in either the CalPERS Anthem or Blue Shield plans, we assumed they will transfer to the United Health Care Medicare Supplement plan upon reaching age 65, as the CalPERS health plan no longer offers Anthem or Blue Shield coverage for Medicare eligible retirees.

**Valuation of Retiree Premium Subsidy Due to Active Health Costs**

Currently, the County and California PERS (PEMHCA) health plans charge the same premiums for retirees who are not yet eligible for Medicare as for active employees. Therefore, the retiree premium rates are being subsidized by the inclusion of active lives in setting rates. (Premiums calculated only based on retiree health claims experience would have resulted in higher retiree premiums.) GASB 45 requires that the value of this subsidy be recognized as a liability in valuations of OPEB costs.

To account for the fact that per member health costs vary depending on age (higher health costs at older ages), we calculated equivalent per member per month (PMPM) costs that vary by age based on the age distribution of covered members, and based on relative cost factors by age. The relative cost factors were developed from the Milliman Health Cost Guidelines<sup>TM</sup>. Based on the carrier premium rates and relative age cost factors assumptions, we developed age adjusted monthly PMPM health costs for 2016 to be used in valuing the implicit rate subsidy.

Effective January 1, 2017, the medical premium tier structure will change from two tiers (retiree only, retiree plus one or more dependents) to three tiers (retiree only, retiree plus one dependent, and retiree plus two or more dependents) for certain Non-Medicare Retirees. We assume no change in the value of the implicit premium rate subsidy for retirees not yet eligible for Medicare due to this change. Under the new tier structure, the active and non-Medicare retiree premium rates would remain pooled and blended meaning an implicit rate subsidy would continue under the proposed plan. However, the liability associated with the implicit rate subsidy could increase, decrease, or stay approximately the same depending on the relative premium costs by rate tier for the new three tier premium structure. Since new relative costs by tier for the proposed three tier structure are not yet known, we could not value the effect the proposed three tier structure would have on the implicit rate subsidy liability in this valuation until the actual rate premiums are known.

The following tables show the age adjusted expected monthly claims cost for a male participant at age 64 for each health plan and relative age factors compared to a male age 64.

Plan	Monthly Age Adjusted Claims Cost for Age 64 Male	Dependent Child Cost Load
CCHP A	\$ 1,311	\$ 209
CCHP B	1,596	252
Kaiser A	1,441	300
Kaiser B	1,401	339
Health Net HMO A	1,950	412
Health Net HMO B	1,702	439
Health Net PPO	1,913	555
California PERS Plans (average)	1,504	0

Relative Claims Cost Factor Compared to Male age 64

Age	Male	Female
50	0.463	0.578
55	0.609	0.674
60	0.790	0.794
64	1.000	0.916

Since retirees eligible for Medicare (age 65 and beyond) are enrolled in Medicare supplemental plans, the premiums for retirees with Medicare are determined without regard to active employee claims experience and no such subsidy exists for this group for medical cost.



**Medical Cost Inflation Assumption**

We assumed future increases to the health costs and premiums are based on the “Getzen” model published by the Society of Actuaries for purposes of evaluating long term medical trend. Under the Patient Protection and Affordable Care Act of 2010, a Federal excise tax will apply for high cost health plans beginning in 2020. A margin to reflect the impact of the excise tax in future years is reflected in the assumed trend. The following table shows the assumed rate increases in future years for Medical premiums.

Calendar Year	County Plans Pre 65	Calendar Year	County Plans Post 65	Calendar Year	PEMHCA Plans Pre 65	Calendar Year	PEMHCA Plans Post 65
2016	4.50%	2016	5.25%	2016	4.50%	2016	5.00%
2017	8.00%	2017	8.25%	2017	8.00%	2017	8.25%
2018	5.50%	2018 – 2021	5.50%	2018 – 2021	5.50%	2018 – 2020	5.50%
2019 – 2020	5.25%	2022 – 2036	5.75%	2022 – 2036	6.25%	2021 – 2036	5.75%
2021 – 2023	5.50%	2037 – 2040	5.50%	2037 – 2038	6.00%	2037 – 2041	5.50%
2024 – 2025	5.75%	2041 – 2043	6.00%	2039 – 2044	5.75%	2042 – 2048	5.25%
2026	6.25%	2044 – 2046	5.75%	2045 – 2057	5.50%	2049 – 2053	5.75%
2027	6.50%	2047	6.00%	2058 – 2063	5.25%	2054 – 2060	5.50%
2028	6.25%	2048	6.25%	2064 – 2065	5.00%	2061 – 2062	5.75%
2029 - 2030	6.50%	2049 – 2053	6.00%	2066 – 2069	4.75%	2063 – 2064	5.50%
2031 – 2036	6.25%	2054 – 2060	5.75%	2070 +	4.50%	2065 – 2067	5.25%
2037 – 2039	6.00%	2061 – 2063	5.50%			2068 – 2069	5.00%
2040 – 2046	5.75%	2064 – 2065	5.25%			2070 – 2091	4.75%
2047 – 2059	5.50%	2066 – 2068	5.00%			2092 +	4.50%
2060 – 2063	5.25%	2069 – 2075	4.75%				
2064 – 2066	5.00%	2076 +	4.50%				
2067 – 2069	4.75%						
2070 +	4.50%						

**Dental Cost** We assumed Dental costs will increase 4.0% annually.

### **Appendix C. Changes in Actuarial Cost Method and Assumptions**

The following is a list of assumption and method changes from the prior actuarial valuation. The Board adopted the changes in April 2016.

#### ***Actuarial Cost Method***

The actuarial cost method used for determining the benefit obligations was changed from the Projected Unit Credit cost method to the individual Entry Age Normal cost method. This is the actuarial cost method adopted by the GASB board in June 2015 for the upcoming GASB 74/75 standards in which the implementation date for the OPEB Fund under GASB 74 will be for the fiscal year ending June 30, 2017, and for the County under GASB 75 will be for the fiscal year ending June 30, 2018.

#### ***Spouse Coverage Election Assumption***

The spouse coverage election assumption was changed from 50% for all new retirees electing coverage to 50% for all new General retirees electing coverage and 60% for all new Safety retirees electing coverage. The assumption is based on a review of the County experience from 2012 to 2015.

#### ***Health Cost Inflation Assumption***

We developed the medical cost trend for the prior valuation based on the "Getzen" model published by the Society of Actuaries for purposes of evaluating long term medical trend. The medical trend includes the effect of the Patient Protection and Affordable Care Act of 2010, on future health costs. The Consolidated Appropriations Act of 2016 delayed the excise tax on high cost plans from 2018 to 2020, and eliminated the Health Insurer Fee for calendar year 2017 only. The Health Insurer Fee will be assessed again in calendar year 2018. The medical trend was updated to reflect these recent legislative changes.

#### ***Retirement Rates for PEPRA Tier Employees***

The PEPRA Tier retirement rates developed by CCCERA was used for employees hired on or after January 1, 2013. The rates are shown in Appendix B.

**Appendix D. Summary of Participant Data**

The following census of participants was used in the actuarial valuation and provided by Contra Costa County.

**Active Employees**

Age	General	Safety	Total
Under 25	110	22	132
25 – 29	490	157	647
30 – 34	816	162	978
35 – 39	952	192	1,144
40 – 44	951	229	1,180
45 – 49	1,064	231	1,295
50 – 54	1,148	105	1,253
55 – 59	999	35	1,034
60 – 64	687	20	707
65 & Over	<u>273</u>	<u>2</u>	<u>275</u>
Total	7,490	1,155	8,645
Average Age on Valuation Date:	45.25		
Average Service on Valuation Date:	10.04		

**Current Retirees**

Age	General	Safety	Total
Under 50	23	67	90
50 – 54	101	153	254
55 – 59	367	188	555
60 – 64	778	201	979
65 – 69	1,248	258	1,506
70 – 74	953	169	1,122
75 – 79	615	90	705
80 – 84	457	69	526
85 & Over	<u>592</u>	<u>67</u>	<u>659</u>
Total	5,134	1,262	6,396
Average Age on Valuation Date:	70.03		



Contra  
Costa  
County

To: Board of Supervisors  
From: David Twa, County Administrator  
Date: November 1, 2016

Subject: Proposed Health Plan Changes for Specified Retirees who Retired on or after January 1, 2016 or opted out of Retiree Support Group Settlement

---

**RECOMMENDATION(S):**

- ACKNOWLEDGE that the majority of active employees and early (“Non-Medicare”) retirees will be enrolling in three tier health plans for the 2017 plan year, at the subsidies shown in negotiated agreements or the management resolution;
- ADOPT proposed health plan changes for specified retirees who either retired on or after January 1, 2016, or opted out of the Retiree Support Group Settlement:
  - Effective January 1, 2017, Non-Medicare retirees will have access to all ten (10) County health plans available to active employees
  - Effective January 1, 2017, Non-Medicare retirees will be placed in a three tier plan structure; and
- ACKNOWLEDGE that the proposed changes will increase the number of plans offered to these specified retirees.

**FISCAL IMPACT:**

No change to County subsidies or costs. The County monthly premiums subsidies for these specified retirees are fixed at the flat dollar amounts stated in the applicable negotiated agreement or management resolution.

APPROVE

OTHER

RECOMMENDATION OF CNTY ADMINISTRATOR

RECOMMENDATION OF BOARD  
COMMITTEE

Action of Board On: **11/01/2016**  APPROVED AS RECOMMENDED  OTHER

Clerks Notes:

**VOTE OF SUPERVISORS**

AYE: John Gioia, District I Supervisor  
Candace Andersen, District II Supervisor  
Mary N. Piepho, District III Supervisor  
Karen Mitchoff, District IV Supervisor  
Federal D. Glover, District V Supervisor

I hereby certify that this is a true and correct copy of an action taken and entered on the minutes of the Board of Supervisors on the date shown.

ATTESTED: November 1, 2016

David J. Twa, County Administrator and Clerk of the Board of Supervisors

Contact: Lisa Driscoll, County Finance  
Director (925) 335-1023

By: June McHuen, Deputy

cc: Ann Elliott, Employee Benefits Manager

## BACKGROUND:

On October 25, 2016, the court gave final approval to the class action settlement in *Retiree Support Group of Contra Costa County et al. v. Contra Costa County*. The Settlement Agreement covers a class of 4,200 retirees who retired on or before January 1, 2016, and participate in County health plans. Pursuant to the Settlement Agreement, the Non-Medicare Retirees in the retiree class will be placed in a three tier premium structure effective January 1, 2017. The County monthly premiums subsidies for the retiree class are fixed at the dollar amounts stated in the Agreement. Effective January 1, 2017, the Settlement Agreement provides a \$150 increase to the fixed monthly premium subsidy for Non-Medicare Retirees in the Retiree Plus Two or More tier only. A separate \$25 increase to the fixed monthly premium subsidy for Medicare Retirees With All Dependents on Medicare occurs in 2021. These specified increases apply only to members of the retiree class.

If approved, this action will move specified Non-Medicare retirees who either retired on or after January 1, 2016 or opted out of Retiree Support Group Settlement to a three tier premium structure effective January 1, 2017. The County monthly premiums subsidies for these specified retirees remain fixed at the flat dollar amounts stated in the applicable negotiated memorandum of understanding or management resolution. Non-Medicare retirees will have access to all ten County health plans, including the Teamsters 856 Trust Fund KP Health Plan.

The specified retirees are those Non-Medicare retirees participating in County health plans who either retired on or after January 1, 2016, or opted out of the Retiree Support Group Settlement and were represented by one of the following bargaining units at the time of retirement:

1. AFSCME 512
2. AFSCME 2700
3. CCC Defenders Association
4. CCC Deputy District Attorneys Association
5. CCC Employees' Association, Local 1
6. IFPTE Local 21
7. Physicians and Dentists Organization of Contra Costa
8. Probation Peace Officers of CCC
9. SEIU Local 1021
10. Teamsters, Local 856
11. Western Council of Engineers
12. Unrepresented

Attached are the medical and dental premiums and subsidies for the 2017 plan year for qualifying retirees.

## CONSEQUENCE OF NEGATIVE ACTION:

Specified Non-Medicare retirees would not have access to the three tier structure, which is generally more advantageous for Retirees and would not have access to all ten County health plans.

## ATTACHMENTS

Medical and Dental Premiums and Subsidies for the 2017 Plan Year for Qualifying Retirees

**RETIRED ON OR AFTER JANUARY 1, 2016 / OPTED OUT OF RSG SETTLEMENT CLASS**

<b>PLAN/COVERAGE DESCRIPTION</b>	<b>2017 TOTAL MONTHLY PREMIUM</b>	<b>2017 COUNTY SUBSIDY</b>	<b>2017 RETIREE MONTHLY SHARE</b>
<b>CONTRA COSTA HEALTH PLAN - BASIC PLAN A</b>			
Retiree on Basic Plan A	\$717.57	\$509.92	\$207.65
Retiree & 1 or more dependents on Basic Plan A	\$1,435.13	\$1,214.90	\$220.23
Retiree & 2 or more dependents on Basic Plan A	\$2,152.71	\$1,214.90	\$937.81
<b>CONTRA COSTA HEALTH PLAN - BASIC PLAN B</b>			
Retiree on Basic Plan B	\$795.44	\$528.50	\$266.94
Retiree & 1 or more dependents on Basic Plan B	\$1,590.88	\$1,255.79	\$335.09
Retiree & 2 or more dependents on Basic Plan B	\$2,386.32	\$1,255.79	\$1,130.53
<b>KAISER PERMANENTE - BASIC PLAN A</b>			
Retiree on Basic Plan A	\$718.07	\$478.91	\$239.16
Retiree & 1 or more dependents on Basic Plan A	\$1,436.14	\$1,115.84	\$320.30
Retiree & 2 or more dependents on Basic Plan A	\$2,154.21	\$1,115.84	\$1,038.37
<b>KAISER PERMANENTE - BASIC PLAN B</b>			
Retiree on Basic Plan B	\$570.73	\$478.91	\$91.82
Retiree & 1 or more dependents on Basic Plan B	\$1,141.45	\$1,115.84	\$25.61
Retiree & 2 or more dependents on Basic Plan B	\$1,712.18	\$1,115.84	\$596.34
<b>KAISER HIGH DEDUCTIBLE</b>			
Employee on Basic Plan	\$458.07	\$458.06	\$0.01
Employee & 1	\$916.14	\$916.13	\$0.01
Employee & 2 or more dependents on Basic Plan	\$1,374.21	\$1,115.84	\$258.37
<b>TEAMSTERS 856 TRUST FUND KP HEALTH PLAN</b>			
Employee on Basic Plan	\$655.00	\$478.91	\$176.09
Employee & 1	\$1,245.00	\$1,115.84	\$129.16
Employee & 2 or more dependents on Basic Plan	\$1,736.00	\$1,115.84	\$620.16
<b>HEALTH NET HMO PLAN - BASIC PLAN A</b>			
Retiree on Basic Plan A	\$1,292.89	\$627.79	\$665.10
Retiree & 1 or more dependents on Basic Plan A	\$2,585.78	\$1,540.02	\$1,045.76
Retiree & 2 or more dependents on Basic Plan A	\$3,878.66	\$1,540.02	\$2,338.64
<b>HEALTH NET HMO PLAN - BASIC PLAN B</b>			
Retiree on Basic Plan B	\$899.05	\$627.79	\$271.26
Retiree & 1 or more dependents on Basic Plan B	\$1,798.10	\$1,540.02	\$258.08
Retiree & 2 or more dependents on Basic Plan B	\$2,697.16	\$1,540.02	\$1,157.14
<b>HEALTH NET CA &amp; NAT'L PPO PLAN - BASIC PLAN A</b>			
Retiree on PPO Basic Plan A	\$1,712.92	\$604.60	\$1,108.32
Retiree & 1 or more dependents on PPO Basic Plan A	\$3,425.83	\$1,436.25	\$1,989.58
Retiree & 2 or more dependents on PPO Basic Plan A	\$5,138.75	\$1,436.25	\$3,702.50

**RETIRED ON OR AFTER JANUARY 1, 2016 / OPTED OUT OF RSG SETTLEMENT CLASS**

PLAN/COVERAGE DESCRIPTION		2017 TOTAL MONTHLY PREMIUM	2017 COUNTY SUBSIDY	2017 RETIREE MONTHLY SHARE
<b>HEALTH NET CA &amp; NAT'L PPO PLAN - BASIC PLAN B</b>				
Retiree on PPO Basic Plan B		\$1,542.05	\$604.60	\$937.45
Retiree & 1 or more dependents on PPO Basic Plan B		\$3,084.10	\$1,436.25	\$1,647.85
Retiree & 2 or more dependents on PPO Basic Plan B		\$4,626.14	\$1,436.25	\$3,189.89
<b>DELTA DENTAL PREMIER PPO - \$1,800 ANNUAL MAXIMUM</b>				
For CCHP Plans	Retiree	\$45.16	\$41.17	\$3.99
	Retiree +1	\$102.00	\$93.00	\$9.00
	Retiree + 2 or more	\$102.00	\$93.00	\$9.00
For Health Net Plans	Retiree	\$45.16	\$34.02	\$11.14
	Retiree +1	\$102.00	\$76.77	\$25.23
	Retiree + 2 or more	\$102.00	\$76.77	\$25.23
For Kaiser Permanente Plans	Retiree	\$45.16	\$34.02	\$11.14
	Retiree +1	\$102.00	\$76.77	\$25.23
	Retiree + 2 or more	\$102.00	\$76.77	\$25.23
Without a Health Plan	Retiree	\$45.16	\$43.35	\$1.81
	Retiree +1	\$102.00	\$97.81	\$4.19
	Retiree + 2 or more	\$102.00	\$97.81	\$4.19
<b>DELTA CARE (HMO)</b>				
For CCHP Plans	Retiree	\$29.06	\$25.41	\$3.65
	Retiree +1	\$62.81	\$54.91	\$7.90
	Retiree + 2 or more	\$62.81	\$54.91	\$7.90
For Health Net Plans	Retiree	\$29.06	\$21.31	\$7.75
	Retiree +1	\$62.81	\$46.05	\$16.76
	Retiree + 2 or more	\$62.81	\$46.05	\$16.76
For Kaiser Permanente Plans	Retiree	\$29.06	\$21.31	\$7.75
	Retiree +1	\$62.81	\$46.05	\$16.76
	Retiree + 2 or more	\$62.81	\$46.05	\$16.76
Without a Health Plan	Retiree	\$29.06	\$27.31	\$1.75
	Retiree +1	\$62.81	\$59.03	\$3.78
	Retiree + 2 or more	\$62.81	\$59.03	\$3.78

**PHYSICIANS AND DENTISTS ORGANIZATION**

<b>PLAN/COVERAGE DESCRIPTION</b>	<b>2017 TOTAL MONTHLY PREMIUM</b>	<b>2017 COUNTY MONTHLY SHARE</b>	<b>2017 RETIREE MONTHLY SHARE</b>
<b>CONTRA COSTA HEALTH PLAN - BASIC PLAN A</b>			
Retiree on Basic Plan A	\$717.57	\$600.51	\$117.06
Retiree & 1 or more dependents on Basic Plan A	\$1,435.13	\$1,430.76	\$4.37
Retiree & 2 or more dependents on Basic Plan A	\$2,152.71	\$1,430.76	\$721.95
<b>CONTRA COSTA HEALTH PLAN - BASIC PLAN B</b>			
Retiree on Basic Plan B	\$795.44	\$611.34	\$184.10
Retiree & 1 or more dependents on Basic Plan B	\$1,590.88	\$1,452.65	\$138.23
Retiree & 2 or more dependents on Basic Plan B	\$2,386.32	\$1,452.65	\$933.67
<b>KAISER PERMANENTE - BASIC PLAN A</b>			
Retiree on Basic Plan A	\$718.07	\$614.78	\$103.29
Retiree & 1 or more dependents on Basic Plan A	\$1,436.14	\$1,432.42	\$3.72
Retiree & 2 or more dependents on Basic Plan A	\$2,154.21	\$1,432.42	\$721.79
<b>KAISER PERMANENTE - BASIC PLAN B</b>			
Retiree on Basic Plan B	\$570.73	\$570.72	\$0.01
Retiree & 1 or more dependents on Basic Plan B	\$1,141.45	\$1,141.44	\$0.01
Retiree & 2 or more dependents on Basic Plan B	\$1,712.18	\$1,432.42	\$279.76
<b>KAISER HIGH DEDUCTIBLE</b>			
Employee on Basic Plan	\$458.07	\$458.06	\$0.01
Employee & 1	\$916.14	\$916.13	\$0.01
Employee & 2 or more dependents on Basic Plan	\$1,374.21	\$1,374.20	\$0.01
<b>TEAMSTERS 856 TRUST FUND KP HEALTH PLAN</b>			
Employee on Basic Plan	\$655.00	\$614.78	\$40.22
Employee & 1	\$1,245.00	\$1,244.99	\$0.01
Employee & 2 or more dependents on Basic Plan	\$1,736.00	\$1,432.42	\$303.58
<b>HEALTH NET HMO PLAN - BASIC PLAN A</b>			
Retiree on Basic Plan A	\$1,292.89	\$853.92	\$438.97
Retiree & 1 or more dependents on Basic Plan A	\$2,585.78	\$2,094.74	\$491.04
Retiree & 2 or more dependents on Basic Plan A	\$3,878.66	\$2,094.74	\$1,783.92
<b>HEALTH NET HMO PLAN - BASIC PLAN B</b>			
Retiree on Basic Plan B	\$899.05	\$853.92	\$45.13
Retiree & 1 or more dependents on Basic Plan B	\$1,798.10	\$1,798.09	\$0.01
Retiree & 2 or more dependents on Basic Plan B	\$2,697.16	\$2,094.74	\$602.42



**PHYSICANS AND DENTISTS ORGANIZATION**

<b>PLAN/COVERAGE DESCRIPTION</b>	<b>2017 TOTAL MONTHLY PREMIUM</b>	<b>2017 COUNTY MONTHLY SHARE</b>	<b>2017 RETIREE MONTHLY SHARE</b>	
<b>HEALTH NET CA &amp; NAT'L PPO PLAN - BASIC PLAN A</b>				
Retiree on PPO Basic Plan A	\$1,712.92	\$753.81	\$959.11	
Retiree & 1 or more dependents on PPO Basic Plan A	\$3,425.83	\$1,790.70	\$1,635.13	
Retiree & 2 or more dependents on PPO Basic Plan A	\$5,138.75	\$1,790.70	\$3,348.05	
<b>HEALTH NET CA &amp; NAT'L PPO PLAN - BASIC PLAN B</b>				
Retiree on PPO Basic Plan B	\$1,542.05	\$753.81	\$788.24	
Retiree & 1 or more dependents on PPO Basic Plan B	\$3,084.10	\$1,790.70	\$1,293.40	
Retiree & 2 or more dependents on PPO Basic Plan B	\$4,626.14	\$1,790.70	\$2,835.44	
<b>DELTA DENTAL PREMIER PPO - \$1,600 ANNUAL MAXIMUM</b>				
For CCHP Plans	Retiree	\$45.16	\$41.60	\$3.56
	Retiree +1	\$102.00	\$93.72	\$8.28
	Retiree + 2 or more	\$102.00	\$93.72	\$8.28
For Health Net Plans	Retiree	\$45.16	\$33.11	\$12.05
	Retiree +1	\$102.00	\$74.59	\$27.41
	Retiree + 2 or more	\$102.00	\$74.59	\$27.41
For Kaiser Permanente Plans	Retiree	\$45.16	\$33.11	\$12.05
	Retiree +1	\$102.00	\$74.59	\$27.41
	Retiree + 2 or more	\$102.00	\$74.59	\$27.41
Without a Health Plan	Retiree	\$45.16	\$42.44	\$2.72
	Retiree +1	\$102.00	\$95.62	\$6.38
	Retiree + 2 or more	\$102.00	\$95.62	\$6.38
<b>DELTA CARE (HMO)</b>				
For CCHP Plans	Retiree	\$29.06	\$28.48	\$0.58
	Retiree +1	\$62.81	\$61.55	\$1.26
	Retiree + 2 or more	\$62.81	\$61.55	\$1.26
For Health Net Plans	Retiree	\$29.06	\$22.67	\$6.39
	Retiree +1	\$62.81	\$48.99	\$13.82
	Retiree + 2 or more	\$62.81	\$48.99	\$13.82
For Kaiser Permanente Plans	Retiree	\$29.06	\$22.67	\$6.39
	Retiree +1	\$62.81	\$48.99	\$13.82
	Retiree + 2 or more	\$62.81	\$48.99	\$13.82
Without a Health Plan	Retiree	\$29.06	\$29.05	\$0.01
	Retiree +1	\$62.81	\$62.80	\$0.01
	Retiree + 2 or more	\$62.81	\$62.80	\$0.01



Contra  
Costa  
County

To: Board of Supervisors  
From: Jeff Carman, Chief, Contra Costa County Fire Protection District  
Date: November 1, 2016

Subject: Public Hearing - Ordinance 2016-23 to Adopt 2016 California Fire Code with Local Amendments

---

**RECOMMENDATION(S):**

Acting in its capacity as the Contra Costa County Board of Supervisors and as the Board of Directors of the Crockett-Carquinez Fire Protection District and the Contra Costa County Fire Protection District:

1. OPEN the public hearing on Ordinance No. 2016-23, adopting the 2016 California Fire Code, with local amendments, as the fire code within Contra Costa County, the Contra Costa County Fire Protection District, and the Crockett-Carquinez Fire Protection District; RECEIVE testimony; CONSIDER all public comments; and CLOSE the public hearing.
2. ADOPT Ordinance No. 2016-23, adopting the 2016 California Fire Code, with local amendments, as the fire code within Contra Costa County, the Contra Costa County Fire Protection District, and the Crockett-Carquinez Fire Protection District.
3. ADOPT the attached findings in support of the amendments to the 2016 California Fire Code.
4. DIRECT the Fire Districts, pursuant to Health and Safety Code section 17958.7, to send a certified copy of Ordinance No. 2016-23, the attached findings, and this Board Order to the California Department of Housing and Community Development and to the California Building Standards Commission.

APPROVE

OTHER

RECOMMENDATION OF CNTY ADMINISTRATOR

RECOMMENDATION OF BOARD  
COMMITTEE

Action of Board On: 11/01/2016  APPROVED AS RECOMMENDED  OTHER

Clerks Notes:

**VOTE OF SUPERVISORS**

AYE: John Gioia, District I Supervisor  
Candace Andersen, District II Supervisor  
Mary N. Piepho, District III Supervisor  
Karen Mitchoff, District IV Supervisor  
Federal D. Glover, District V Supervisor

I hereby certify that this is a true and correct copy of an action taken and entered on the minutes of the Board of Supervisors on the date shown.

ATTESTED: November 1, 2016

David J. Twa, County Administrator and Clerk of the Board of Supervisors

Contact: Robert Marshall, Fire Marshal  
(925) 941-3520

By: June McHuen, Deputy

cc:

RECOMMENDATION(S): (CONT'D)

5. AUTHORIZE the publication of the ordinance summary prepared by County Counsel in accordance with Government Code section 25124.
6. DIRECT the Clerk of the Board of Supervisors to post at its office, and each Fire District to post at its office, a certified copy of the full text of Ordinance No. 2016-23, as adopted, with the names of the Supervisors/Directors voting for and against the ordinance, in accordance with Government Code section 25124.
7. FIND that adoption of the ordinance is exempt from CEQA pursuant to CEQA guidelines section 15061(b)(3).
8. DIRECT staff to file a Notice of Exemption with the County Clerk.

FISCAL IMPACT:

The fiscal impact is neutral. The adoption of this ordinance will provide the administrative authority to enforce the provisions of the California Fire Code as amended.

BACKGROUND:

The California Building Standards Commission has adopted and published the 2016 Building Standards Code, which includes the 2016 California Fire Code prepared and adopted by the State Fire Marshal. The statewide code becomes effective January 1, 2017.

Although the code applies statewide, Health and Safety Code sections 17958.5 and 18941.5 authorize a local jurisdiction to modify or change the statewide code and establish more restrictive standards if the jurisdiction finds that the modifications and changes are reasonably necessary because of local climatic, geological, or topographical conditions. Ordinance No. 2016-23 adopts the 2016 California Fire Code and amends it to address local conditions. There are several material changes to the local ordinance previously adopted by the Board in the 2013 code adoption process, as detailed below.

The attached ordinance amends the 2016 California Fire Code by establishing automatic sprinkler system requirements that are more restrictive than the sprinkler requirements in the statewide code. The attached ordinance requires the installation of automatic fire sprinkler systems in most commercial buildings greater than 5,000 square feet, and in private and charter schools greater than 2,000 square feet. New public schools are required to install fire sprinklers regardless of square footage. Reducing the sprinkler threshold to 2,000 square feet for private schools brings the requirement more in line with public schools. Several other occupancies were clarified to require sprinklers as well, including light hazard warehouse type occupancies. The more restrictive requirements are necessary due to Contra Costa County's climatic, geological, and topographical conditions, which impact fire prevention efforts and the frequency, spread, acceleration, intensity, and size of fire involving buildings. The automatic sprinkler system requirements are set forth in Section 903.2 of the attached ordinance. The automatic sprinkler system requirements specific to schools are set forth in Section 903.2.3 of the attached ordinance.

The attached ordinance also clarifies a requirement for standby EMS personnel for large events that may tax the EMS system. The clarification is necessary because the statewide code as written does not assume that a fire agency is also an ambulance providing entity.

The fire districts' existing weed abatement program is incorporated into Section 320 of the ordinance. This program authorizes the fire districts to declare certain weeds that pose a fire hazard as a public nuisance, to abate those weeds, and to recover abatement costs from property owners.

Chapter 5 and Appendix D of the ordinance establish requirements for fire apparatus access roads, including requirements for turnouts, parking on access roads, and maximum grades.

Several other provisions were removed from the local ordinance previously adopted by the Board in the 2013 code adoption process because the provisions have been incorporated into the updated 2016 California Fire Code.

Notice of the public hearing was published in accordance with Government Code section 6066. A summary of the ordinance was prepared and published in accordance with Government Code section 25124(b).

CONSEQUENCE OF NEGATIVE ACTION:

Without the adoption of the 2016 California Fire Code (CFC) with local amendments, the Fire District will not have the legal authority to enforce any exterior hazard abatement standards or the ability to conduct fire and life safety inspections in occupancies other than high-rise buildings, schools, hotels, motels, apartments, and day care facilities. In addition, without adoption of the CFC, occupancies that conduct operations such as the production, storage, and sale of hazardous materials, places of assembly, and the review of construction documents and testing of fire protection and fire alarm systems would no longer be regulated by the Fire District.

Furthermore, adoption of the 2016 CFC is necessary to continue allowing the Fire District to collect fees to recover the costs of providing fire prevention related services. Without adoption of the CFC, as amended, the Fire District general fund revenues would be required to provide the fiscal support necessary to fund the positions currently supported by operational permit and inspection fees and new construction plan review fees. This would result in a decrease in the amount of general fund revenues available for conducting emergency response activities or critical fire prevention services and personnel would need to be reduced or eliminated.

CHILDREN'S IMPACT STATEMENT:

No impact.

CLERK'S ADDENDUM

***CLOSED the public hearing;***

***ADOPTED Ordinance No. 2016-23, adopting the 2016 California Fire Code, with local amendments, as the fire code within Contra Costa County, the Contra Costa County Fire Protection District, and the Crockett-Carquinez Fire Protection District; ADOPTED findings in support of the amendments to the 2016 California Fire Code; DIRECTED the Fire Districts, pursuant to Health and Safety Code section 17958.7, to send a certified copy of Ordinance No. 2016-23, the attached findings, and this Board Order to the California Department of Housing and Community Development and to the California Building Standards Commission.***

***AUTHORIZED the publication of the ordinance summary prepared by County Counsel in accordance with Government Code section 25124; DIRECTED the Clerk of the Board of Supervisors to post at its office, and each Fire District to post at its office, a certified copy of the full text of Ordinance No. 2016-23, as adopted, with the names of the Supervisors/Directors voting for and against the ordinance, in accordance with Government Code section 25124; FOUND that adoption of the ordinance is exempt from CEQA pursuant to CEQA guidelines section 15061(b)(3); and DIRECTED staff to file a Notice of Exemption with the County Clerk.***

AGENDA ATTACHMENTS

Ordinance 2016-23

Ordinance 2016-23 Findings of Fact

MINUTES ATTACHMENTS

Signed Ordinance 2016-23

ORDINANCE NO. 2016-23

FIRE CODE

ORDINANCES OF THE COUNTY OF CONTRA COSTA, THE CROCKETT-CARQUINEZ FIRE PROTECTION DISTRICT, AND THE CONTRA COSTA COUNTY FIRE PROTECTION DISTRICT ADOPTING THE 2016 CALIFORNIA FIRE CODE WITH AMENDMENTS.

The Contra Costa County Board of Supervisors, as the Board of Supervisors for Contra Costa County and as the Board of Directors of the Crockett-Carquinez Fire Protection District and the Contra Costa County Fire Protection District, ordains as follows:

SECTION 1. ADOPTION OF THE CALIFORNIA FIRE CODE.

Contra Costa County, the Crockett-Carquinez Fire Protection District, and the Contra Costa County Fire Protection District hereby adopt the 2016 California Fire Code (California Code of Regulations, Title 24, Part, 9 [based on the 2015 International Fire Code published by the International Code Council]), including Chapters 1-10 and 12-80, Appendix B, Appendix C, Appendix D, Appendix F, Appendix H, Appendix I, Appendix J, and Appendix K, as amended by the changes, additions, and deletions set forth in this ordinance. The 2016 California Fire Code, with the changes, additions, and deletions set forth this ordinance, is adopted by this reference as though fully set forth in this ordinance. As of the effective date of this ordinance, the provisions of the fire code are controlling and enforceable within the limits of each jurisdiction.

SECTION 2. AMENDMENTS TO THE CALIFORNIA FIRE CODE.

The 2016 California Fire Code is amended by the changes, additions, and deletions set forth in this Section 2. Chapter and Section numbers used below are those of the 2016 California Fire Code.

**Chapter 1. Scope and Administration.**

Section 101.1 is amended to read:

**101.1 Title.** This code is the Fire Code of Contra Costa County, the Crockett-Carquinez Fire Protection District, and the Contra Costa County Fire Protection District, and is hereinafter referred to as “this code.”

Section 102.1 is amended to add item 5, to read:

5. Where not otherwise limited by law, the provisions of this code shall apply to vehicles, ships, and boats that are permanently affixed to a specific location within the boundaries of this jurisdiction.

Section 105.6 is amended to read:

**105.6 Required operational permits.** The fire code official is authorized to issue operational permits for the operations set forth in Chapter 1, Sections 105.6.1 through 105.6.60.

Section 105.6.5 is amended to read:

**105.6.5 Carnivals, Fairs, Festivals and Exhibitions.** A permit is required to operate a carnival, fair, festival, or exhibition.

Section 105.6.31 is amended to read:

**105.6.31 Motor Fuel Dispensing Facilities.** An operational permit is required for the operation of automotive, marine, and fleet motor fuel dispensing facilities, as well as for sites that allow mobile fueling from a service provider to the general public.

Section 105.6 is amended by adding subsections 105.6.50 through 105.6.60, to read:

**105.6.50 Asbestos removal.** A permit is required to conduct asbestos-removal operations regulated by Section 3318.

**105.6.51 Automobile Wrecking or Dismantling Yard.** An operation permit is required for all automobile wrecking yards, automobile dismantling operations, and similar operations.

**105.6.52 Battery systems.** A permit is required to operate stationary lead-acid battery systems having a liquid capacity of more than 50 gallons (189 L) pursuant to Section 608.

**105.6.53 Christmas tree sales.** A permit is required to use a property for the purpose of selling cut Christmas trees.

**105.6.54 Emergency Responder Radio Coverage.** A permit is required for facilities with Emergency Responder Radio Coverage Systems.

**105.6.55 Firework aerial display.** A permit is required to conduct a firework display regulated by California Code of Regulations, Title 19 and Chapter 56 of this code.

**105.6.56 Model rockets.** A permit is required to sell model rocket motors or launch model rockets (in excess of 3 launches per event) pursuant to California Code of Regulations, Title 19, Division 1, Article 17. Permits issued in accordance with this section are for the site, and are effective as long as site conditions have not changed.

**105.6.57 Temporary water supply.** A permit is required to use a temporary water supply for construction of residential projects or subdivisions pursuant to Section 3312.1.

**105.6.58 Tire storage.** A permit is required to store more than 1,000 cubic feet (28.3m<sup>3</sup>) of tires inside buildings pursuant to Chapter 34.

**105.6.59 Oil Extraction Process.** A permit is required to operate a process that uses a volatile solvent or Liquid Carbon Dioxide to extract oil from organic material.

**105.6.60 Indoor Growing Operation.** A permit is required to operate an indoor growing operation.  
**Exception:** Agricultural Greenhouses in an agricultural zone.

Section 105.7 is amended to read:

**105.7 Required construction permits.** The fire code official is authorized to issue construction permits for the operations set forth in Chapter 1, Sections 105.7.1 through 105.7.21.

Section 105.7 is amended by adding Sections 105.7.17 through 105.7.22, to read:

**105.7.17 Access for fire apparatus.** Plans shall be submitted and a permit is required to install, improve, modify, or remove public or private roadways, driveways, and bridges for which Fire District access is required by the Fire Code. A permit is required to install a gate across a fire apparatus access road pursuant to Section 503.

**105.7.18 Construction, alteration, or renovation of a building for which a building permit is required.** Plans shall be submitted to the fire code official for all land developments or for the construction, alteration, or renovation of a building within the jurisdiction where a building permit is required.

**Exception:** Non-sprinklered Group R-3 Occupancies where work does not involve a substantial addition or expansion.

**105.7.19 Medical gas systems.** A construction permit is required for the installation of or modification to a medical gas system pursuant to Section 5306.

**105.7.20 Refrigeration equipment.** A permit is required to install a mechanical refrigeration unit or system regulated by Chapter 6 and/or the California Mechanical Code.

**105.7.21 Land Development, Subdivisions.** Plans shall be submitted to the fire code official for all land developments or improvements proposed within the jurisdiction that involve the subdivision of land.

**105.7.22 Water supply for fire protection.** Plans shall be submitted to the fire code official for the purpose of determining whether adequate water supplies, fire hydrants, and associated systems are provided for all facilities, buildings, or portions of buildings either constructed or moved into the District pursuant to Section 507.

Section 105.8 is added, to read:

**105.8 Responsibility of permittee.** Construction permits shall be presumed by the Fire District to incorporate all of the work that the applicant or the applicant's agent, employees, or contractors shall carry out. Work performed shall be in accordance with the approved plans and with all requirements of this code and any other laws or regulations applicable thereto. No Fire District approval shall relieve or exonerate any person from the responsibility of complying with the provisions of this code nor shall any vested rights be created for any work performed in violation of this code.

Section 108.1 is amended to read:

**108.1 Board of Appeals established.** In order to hear and decide appeals of orders, decisions, or determinations made by the fire code official relative to the application and interpretation of this code, there is hereby created a board of appeals. The board of appeals is comprised of the Board of Directors.

Section 108.3 is deleted.

Section 109.4 is amended to read:

**109.4 Violation penalties.** Every person who violates any provision of this fire code is guilty of an infraction or misdemeanor in accordance with Health and Safety Code Section 13871 and Government Code Section 53069.4. The imposition of one penalty for any violation shall not excuse the violation or

permit it to continue; and all such persons shall be required to correct or remedy such violations or defects within a reasonable time; and when not otherwise specified, each ten (10) days that prohibited conditions are maintained shall constitute a separate offense. The application of the aforesaid penalty shall not be held to prevent the enforced removal of prohibited conditions.

Section 111.4 is amended to read:

**111.4 Failure to comply.** Any person who continues any work after having been served with a stop work order is subject to citation, except any work that a person is directed by the fire code official to perform to remove a violation or unsafe condition.

## **Chapter 2. Definitions.**

Section 202 is amended by adding the following definitions to that section:

**Administrator.** Fire Chief.

**All-weather driving surface.** A roadway with a minimum surface finish of one layer of asphalt or concrete that is designed to carry the imposed weight loads of fire apparatus.

**Automobile Dismantling.** The operation of dismantling or removing parts from salvaged vehicles including engines or engine parts.

**Automobile Wrecking Yard.** An area that stores or dismantles salvaged vehicles.

**Board of Directors.** The Contra Costa County Board of Supervisors as the governing body of the Crockett-Carquinez Fire Protection District and the Contra Costa County Fire Protection District.

**Board of Fire Commissioners.** An advisory commission appointed by the Board of Directors to act as set forth in this ordinance and by resolutions of the Board of Directors.

**Cost of Abatement.** Includes all expenses incurred by the jurisdiction in its work of abatement and administrative costs pursuant to Section 319.5 of this code.

**Defensible Space.** The area within the perimeter of a parcel providing the key point of defense from an approaching wildland or escaping structure fire.

**Driveway.** A private roadway that provides access to no more than two (2) single-family dwellings.

**Fire Code Official.** In the Contra Costa County Fire Protection District, the Fire Code Official is the Fire Marshal. In the Crockett-Carquinez Fire Protection District, the Fire Code Official is the Fire Chief.

**Firebreak.** A continuous strip of land upon and from which all rubbish, weeds, grass, or other growth that could be expected to burn has been abated or otherwise removed in order to prevent extension of fire from one area to another.

**Firetrail.** A graded firebreak of sufficient width, surface, and design to provide access for personnel and equipment to suppress and to assist in preventing a surface extension of fires.



**Nuisance Fire Alarm.** The activation of any fire protection or alarm system which results in the response of the Fire District and is caused by malfunction, improper maintenance, negligence, or misuse of the system by an owner, occupant, employee, or agent, or any other activation not caused by excessive heat, smoke, fire, or similar activating event.

**Person.** Includes individuals, firms, partnerships, and corporations.

**Priority Hazard Zone.** An area where the threat from wildfire is severe due to proximity to open space, topography, degree of space, density of homes and/or amount of vegetation (native and ornamental), and/or other conditions favorable to fast moving fires.

**Reduced Fuel Zone.** The area that extends from thirty (30) feet to one hundred (100) feet away from the structure, or to the property line, whichever is closer to the structure.

**Response time.** The elapsed time from receipt of call to the arrival of the first unit on scene.

**Rubbish.** Waste matter, litter, trash, refuse, debris, and dirt on streets or private property in the jurisdiction which is, or when dry may become, a fire hazard.

**Rural area.** An area generally designated for agricultural or open space uses with parcels more than 10 acres (4.046873ha) in size.

**Rural residential area.** An area generally designated for single family residential use with parcels between three (1.2140619ha) and 10 (4.046873ha) acres in size.

**Running time.** The calculated time difference between leaving the first-due station and arriving on the emergency scene.

**Sprinkler Alarm and Supervisory System (SASS).** A Dedicated Function Fire Alarm System located at the protected premise installed specifically to monitor sprinkler water-flow alarm, valve supervisory, and general trouble conditions where a Building Fire Alarm is not required.

**Streets.** Includes alleys, parkways, driveways, sidewalks, and areas between sidewalks and curbs, highways, public right of ways, private road, trails, easements, and fire trails.

**Substantial Addition or Expansion.** Addition, expansion, remodel, or renovation of any structure where the addition of new fire area exceeds fifty percent of the existing fire area. For the purposes of this definition, areas of a building in which construction elements including walls and roof assemblies were demolished and rebuilt are considered new fire area.

**Temporary fire department access road for construction.** An approved temporary roadway for emergency vehicle use during construction of residential subdivision projects.

**Temporary fire department access road for construction of one (1) residential (R3) unit.** A temporary roadway for emergency vehicle use during construction of an individual residential (R3) structure where a fire department access road is required as part of the project.

**Temporary water supply.** Water stored for firefighting purposes in an approved aboveground tank during combustible construction.

**Tree litter.** Any limbs, bark, branches, and/or leaves in contact with other vegetation or left to gather on the ground.

**Weeds.** All weeds growing upon streets or private property in the jurisdiction, including any of the following:

1. Weeds that bear seeds of a fluffy nature or are subject to flight.
2. Sagebrush, chaparral (including Chamise, Coyote Brush/Greasewood, Brooms, and Buckwheat), and any other brush or weeds that attain such large growth as to become, when dry, a fire menace to adjacent improved property.
3. Weeds that are otherwise noxious or dangerous.
4. Poison oak and poison sumac when the conditions of growth constitute a menace to public health.
5. Dry grass, brush, tree litter, litter, or other flammable materials that endanger the public safety by creating a fire hazard.

### **Chapter 3. General Precautions Against Fire.**

Section 304.1.2 is amended to read:

**304.1.2 Vegetation.** Hazards created by the growth of weeds, grass, vines, trees, or other growth capable of being ignited and endangering property shall be mitigated in accordance with Section 320.

Section 304.1.4 is added, to read:

**304.1.4 Clothes Dryers.** Clothes dryers shall be frequently cleaned to maintain the lint trap, mechanical and heating components, vent duct, and associated equipment free from accumulations of lint and combustible materials.

Section 308.1.4, Exception 1 is amended to read:

**Exception 1.** Residential Occupancies.

Section 320 is added to Chapter 3, to read:

### **SECTION 320 Exterior Fire Hazard Control.**

#### **320.1 General.**

**320.1.1 Jurisdictional Authority.** The Board of Directors, as the supervising, legislative, and executive authority of the jurisdiction, hereby delegates to the Board of Fire Commissioners of the jurisdiction all its powers, duties, and rights to act pursuant to Part 5 (commencing with Section 14875), Division 12, of the Health and Safety Code, to clear or order the clearing of rubbish, litter, or other flammable material where such flammable material endangers the public the safety by creating a fire hazard. Fire hazard abatement will be conducted in accordance with the provisions of said Part 5 and this ordinance. In the application of the provisions of said Part 5 to fire hazard abatement proceedings under this ordinance and the Fire Protection District Law of 1987, the terms "Board of Directors" or "Board," when used in Part 5, means the Board of Fire Commissioners of this jurisdiction under this section; and the officers designated in Health and Safety Code Section 14890 are the employees of the jurisdiction.

**320.1.2 Retention of Jurisdictional Authority.** If no Board of Fire Commissioners has been appointed for the jurisdiction, then the Board of Directors retains its powers and rights to act pursuant to said Part 5.

**320.1.3 Contract for Services.** The Board of Directors reserves and retains the power to award a contract for fire hazard abatement work when the employees of the jurisdiction are not used to perform the abatement work.

**320.2 Definitions.** The following terms are defined in Chapter 2:

**Cost of Abatement**  
**Defensible Space**  
**Person**  
**Priority Hazard Zone**  
**Reduced Fuel Zone**  
**Rubbish**  
**Streets**  
**Weeds**

**320.3 Weeds and Rubbish a Public Nuisance.** The Board hereby declares that all weeds growing upon private property or streets in this jurisdiction and all rubbish on private property or streets in this jurisdiction are public nuisances. Such weed nuisance is seasonal and recurrent.

**320.4 Abatement of Hazard.**

**320.4.1 Prohibition.** No person who has any ownership or possessory interest in or control of parcel of land shall allow to exist thereon any hazardous rubbish, weeds, trees, or other vegetation that constitutes a fire hazard. Destruction by burning within this jurisdiction is unlawful unless the written permission of the fire chief is first obtained, and all other applicable permits are obtained from appropriate governing agencies or jurisdictions.

**320.4.2 Specific Requirements.** The District shall develop minimum abatement standards for land in residential, rural and/or rural residential, business, industrial areas, or land which is unused or vacant. Such standards may be modified periodically as circumstances dictate.

**320.4.2.1 Clearance of Weeds from Streets.** The Fire Code Official is authorized to cause areas within 10 feet (3048 mm) on each side of portions of streets which are improved, designed, or ordinarily used for vehicular traffic to be cleared of flammable vegetation and other combustible growth. The Fire Code Official is authorized to enter upon private property to do so, to the extent allowed by law.

**320.5 Abatement Procedures.**

**320.5.1 Abatement Order.** The fire code official may order the abatement of the weeds and rubbish described in Sections 304.1.2 and this Section 320. On making the order, the fire code official will mail a copy of a notice to the owners of the affected property as their names and addresses appear upon the last county equalized assessment roll, or as their names and addresses are known to the fire code official. As an alternative to mailing, the notice may be posted upon the affected property and published in the jurisdiction, not less than 15 days prior to the date of the abatement hearing. Copies of the notice will be

headed with the words "Notice to Abate Weeds and Rubbish" in letters at least one inch high. The notice will be in substantially the following form:

#### NOTICE TO ABATE WEEDS AND RUBBISH

You are hereby notified that weeds and rubbish constitute a fire hazard on the following described property owned by you:

(Describe property by common street designation, by metes and bounds, Assessor's code area and parcel number, or by reference to attached map).

You must remove the weeds and rubbish within fifteen (15) days from the date of this notice. If you fail to do so, the (jurisdiction) Fire Protection District will remove it, and the cost of the abatement, including administrative costs, will be collected as property taxes and will be a lien on your property until paid.

You are further notified that the Board of Supervisors has declared that such weeds and rubbish constitute a public nuisance and that such weeds also constitute a seasonal and recurring nuisance.

You may appear before the Board of Fire Commissioners of this jurisdiction on (time and date) at (place-room, street, address, and city) to show cause why this order should not be enforced.

(Signed): (Name of fire code official of name of jurisdiction)

**320.5.2 Hearing Date.** A date for hearing on the notice will be sent at least 15 days after the date of the notice. The date of the notice is the date on which the notice is placed in the United States mail or the date on which it is posted on the property. At the hearing, the property owner or his agent may appear to show cause why the order should not be enforced. For good cause shown, the Board of Fire Commissioners may extend the time for compliance with the order or may rescind the order.

**320.5.3 Contract Award.** If the owner fails to comply with the order, the fire code official may have the weeds and rubbish abated either by employees of this jurisdiction or by contract. If a contract is awarded, it will be by public bid, awarded to the lowest responsible bidder. A contract may include work on more than one parcel. Concerning any contract previously awarded as provided in this subsection and that has been fully extended as provided in that contract, it may thereafter be extended on its same terms and conditions for a further period (not to exceed one year) by agreement of the Board of Supervisors and the involved contractor.

**320.5.4 Abatement Report of Costs.** The fire code official or his or her designee abating the nuisance will keep an account of the cost of abatement in front of or on each separate parcel of land and will render an itemized report in writing to the Board of Fire Commissioners showing the cost of removing the weeds and rubbish on or in front of each separate lot or parcel of land, or both. Before the report is submitted to the Board of Fire Commissioners, a copy of it will be posted for at least three days on or near the chamber door of the Board with a notice of the time and when the report will be submitted to the Board for confirmation. At the time fixed for receiving and considering the report, the Board of Fire Commissioners will hear it and any objections of any of the property owners liable to be assessed for the work of abatement. Thereupon, the Board of Fire Commissioners may make such modifications in the report as it deems necessary, after which the report will be confirmed. The amount of the cost, including administrative costs, of abating the nuisance in front of or upon the various parcels of the land mentioned in the report as confirmed will constitute special assessment against the respective parcels of land, and are a lien on the property for the

amount of the respective assessments. Such lien attaches upon recordation, in the office of the County Recorder, of a certified copy of the Resolution of Confirmation.

**320.5.5 Cost Assessments.** Upon confirmation of the report of cost by the Board of Fire Commissioners and the recordation of the Resolution of Confirmation, a copy of the report of cost will be sent to the County Auditor, who will enter the amount of the assessments against the parcels. Thereafter the amount of the assessments will be collected at the same time and in the same way as County taxes are collected. The owners are subject to the same penalties and the same procedure and sale in case of delinquency as provided for ordinary county taxes. All laws applicable to the levy, collection, and enforcement of county taxes are applicable to these assessment taxes.

**320.6 Alternate Mitigation.** In lieu of ordering abatement as provided in Section 320.5.1, the fire code official of this jurisdiction may order the preparation of firebreaks/fuelbreaks around parcels of property where combustible weeds, crops, or brush are present. In determining the proper width for firebreaks/fuelbreaks, the fire code official will consider the height of the growth, weather condition, topography, and the accessibility to the property for fire protection equipment. The procedure set forth in Section 320.5.1 for the abatement of weeds and rubbish shall apply to the preparation of firebreaks/fuelbreaks.

### **320.7 Subsurface Fires.**

**320.7.1 Peat Fire.** It is the duty of each person, firm, corporation, or association not to permit a peat fire or a fire involving combustible vegetable matters under the surface of the natural ground to remain upon the property. It is hereby declared that it is the duty of any person as herein defined to take all necessary precautions to extinguish any subsurface fire involving peat or vegetable material at the owner's own cost and expense.

**320.7.2 Fire Suppression Costs.** If there exists upon the lands or property of any person as herein defined a subsurface fire involving the burning or combustion of peat, vegetable matter, or vegetation, and the owner or occupant thereof has not taken reasonable precautions within a reasonable time to extinguish or minimize such fire or combustion, this jurisdiction may, in addition to its regular duties to extinguish or minimize such fire or combustion, go upon the lands of any person as herein defined and extinguish such fire or combustion. Any costs incurred by the Fire District in fighting the fire and for the cost of proving rescue or emergency medical services shall be a charge against the property owner. The charge shall constitute a debt of the property owner and is collectable by the jurisdiction incurring those costs in the same manner as in the case of an obligation under a contract, express or implied. (See Health and Safety Code, §13009.)

Section 321 is added to Chapter 3, to read:

### **321 Automobile Wrecking Yards.**

**321.1 General.** The operation of automobile wrecking yards shall be in accordance with this section.

**321.2 Definitions.** The following terms are defined in Chapter 2:

**Automobile Dismantling**  
**Automobile Wrecking Yard**

### **321.3 Requirements.**

**321.3.1 Permits.** An operational fire code permit is required as in Section 105.6.51.

**321.3.2 Fire Apparatus Access Roads.** Fire apparatus access roads shall be constructed throughout the site in accordance with this code and shall be maintained clear of all vehicles and stored items.

**321.3.3 Welding and cutting.** Welding and cutting operations shall be conducted in an approved location, clear of all flammable liquids and combustible materials, including weeds, tires, and all other debris.

**321.3.4 Housekeeping.** Combustible rubbish accumulated on site shall be collected and stored in approved containers, rooms, or vaults of noncombustible materials. Combustible vegetation, cut or uncut, shall be removed when determined by the fire code official to be a fire hazard.

**321.3.5 Fire Protection.** Offices, storage buildings, and vehicles used for site operations shall each be provided with at least one portable fire extinguisher with not less than a 4-A: 40-B-C rating. When required by the fire code official, additional fire extinguishers shall be provided.

**321.3.6 Tire storage.** Tires shall be stored in racks or in a manner as approved by the fire code official.

**321.3.6.1 Distance from Water Supply.** Tire storage shall be located on-site and no further than 500 feet from a fire hydrant or an approved water supply as determined by the fire code official.

**321.3.7 Storage Piles.** Storage piles shall be located a minimum of 20 feet from property lines and shall have an unobstructed access road on all sides of not less than 20 feet.

**321.3.8 Burning operations.** The burning of salvaged vehicles and salvaged or waste materials is prohibited.

**321.3.9 Motor vehicle fluids.** Motor vehicle fluid shall be drained from salvaged vehicles when such liquids are leaking onto the ground and prior to dismantling or removing engine/motor parts.

**321.3.9.1 Mitigation of leaking fluids.** Precautions shall be taken to prevent fluids from salvaged vehicles from leaking onto the ground. Supplies or equipment capable of mitigating leaks from fuel tanks, crankcases, brake systems, and transmissions shall be kept available on site. Single-use plugs, diking, and absorbent materials shall be disposed of as hazardous waste and removed from the site in a manner in accordance with federal, state, and local requirements.

**321.3.10 Fuel tanks.** Fuel tanks of salvaged vehicles shall be emptied of all flammable (gasoline, diesel) fuels in an approved manner and stored in approved tanks.

**321.3.10.1 Repair of vehicle fuel tanks.** The repair of fuel tanks, including cutting, welding, or drilling of any kind, is prohibited.

**321.3.11 Lead acid batteries.** Lead acid batteries shall be removed from all salvaged vehicles and stored in an approved manner in a location approved by the fire code official.

## **Chapter 4. Emergency Planning and Preparedness.**

Section 401.5.1 is added, to read:

**401.5.1 Nuisance Fire Alarm Fee.** A fee may be charged for false and/or nuisance fire alarms in accordance with a fee schedule adopted by the Board of Directors.

Section 403.12.1 is amended to read:

**403.12.1 Standby Personnel.** Where, in the opinion of the fire code official or Fire Chief, it is essential for public safety in a place of assembly, or any other place where people congregate, because of the number of persons, or the nature of the performance, exhibition, display, contest, or activity, the owner, agent, or lessee shall provide standby personnel as required and approved by the fire code official or Fire Chief. If the activity requires fire watch, fire watch shall be provided in accordance with Sections 403.12.1.1 and 403.12.1.2. Standby personnel needed for EMS standby shall be provided in accordance with Contra Costa County EMS Protocols.

## **Chapter 5. Fire Service Features.**

Section 503.1.4 is added, to read:

**503.1.4 Access to Open Spaces.** When existing access to open land or space, or to fire trail systems maintained for public or private use, is obstructed by new development of any kind, the developer shall provide an alternate means of access into the area that is sufficient to allow access for fire personnel and apparatus. The alternate means of access must be approved by the fire code official.

Section 503.2.1 is amended by adding the following exception:

**Exception:** A minimum 16 foot wide driveway is acceptable for access to one or two single-family dwellings.

Section 505.3 is added, to read:

**505.3 Street names and addressing.** Street names and addressing shall be submitted for review and approval to the fire code official, whose approval will not be unreasonably withheld. The purpose of the review is to verify that new street names and addressing will not duplicate existing street names and addressing.

Section 507.2.3 is added, to read:

**507.2.3 Suburban and rural water supply storage.** Swimming pools and ponds shall not be considered water storage for the purposes of Section 507.1.

## **Chapter 6. Building Services and Systems.**

Section 603.6.6 is added, to read:

**603.6.6 Sparks from chimneys.** A chimney that is used with either a fireplace or heating appliances in which solid or liquid fuel is used shall be maintained with spark arresters that are required for incinerators pursuant to the 2016 California Mechanical Code.

## **Chapter 8. Interior Finish, Decorative Materials and Furnishings.**

Section 806.1.4 is added, to read:

**806.1.4 Flame retardants.** Cut trees shall be treated by a California State Fire Marshal-licensed fire retardant applicator. Trees shall be properly treated with an approved flame retardant.

Section 806.1.5 is added, to read:

**806.1.5 Tags.** Trees shall bear a tag stating date of placement in the public building, type of flame-retardant treatment used, name of the person who applied the flame retardant, the name of the person affixing the tag, a permit expiration date, and the name of the designated individual making daily tests.

Section 806.1.6 is added, to read:

**806.1.6 Daily tests.** Trees shall be tested daily by a designated individual. The test shall include a check for dryness in accordance with Section 806.1.3 and for adequate watering.

## **Chapter 9. Fire Protection Systems.**

Section 901.6.2 is amended to read:

**901.6.2 Records.** Records of all system inspections, tests, and maintenance required by the reference standards shall be maintained in paper form and/or by a third party electronic record keeping service as chosen by the fire district.

Section 902 is amended to add:

### **Substantial Addition or Expansion**

Section 903.2.1.1 is amended to read:

**903.2.1.1 Group A-1.** An automatic sprinkler system shall be provided for fire areas containing Group A-1 occupancies and intervening floors of the building where one of the following conditions exists:

1. The fire area exceeds 5,000 square feet.
2. The fire area has an occupant load of 300 or more.
3. The fire area is located on a floor other than a level of exit discharge serving such occupancies.
4. The fire area contains a multi-theater complex.

Section 903.2.1.3 is amended to read:

**903.2.1.3 Group A-3.** An automatic sprinkler system shall be provided for fire areas containing Group A-3 occupancies and intervening floors of the building where one of the following conditions exists:

1. The fire area exceeds 5,000 square feet.
2. The fire area has an occupant load of 300 or more.
3. The fire area is located on a floor other than a level of exit discharge serving such occupancies.
4. The structure exceeds 10,000 square feet, contains more than one fire area containing exhibition and display rooms, and is separated into two or more buildings by fire walls of less than four hour fire resistance rating without openings.



Section 903.2.1.4 is amended to read:

**903.2.1.4 Group A-4.** An automatic sprinkler system shall be provided for fire areas containing Group A-4 occupancies and intervening floors of the building where one of the following conditions exists:

1. The fire area exceeds 5,000 square feet
2. The fire area has an occupant load of 300 or more.
3. The fire area is located on a floor other than a level of exit discharge serving such occupancies.

Section 903.2.1.8 is amended to read:

**903.2.1.8 Group B.** An automatic sprinkler system shall be provided for Group B occupancies where the fire area exceeds 5,000 square feet.

Section 903.2.3 is amended to read:

**903.2.3 Group E.** An automatic sprinkler system shall be provided for new Group E occupancies as follows:

1. Throughout all Group E fire areas greater than 2,000 square feet in area.  
**Exception:** An automatic sprinkler system is not required in any Group E Day Care Facility less than 5,000 square feet
2. Throughout every portion of educational buildings below the lowest level of exit discharge serving that portion of the building.  
**Exception:** An automatic sprinkler system is not required in any area below the lowest level of exit discharge serving that area where every classroom throughout the building has at least one exterior exit door at ground level.
3. In rooms or areas with special hazards such as laboratories, vocational shops, and other such areas where hazardous materials in quantities not exceeding the maximum allowable quantity are used or stored.
4. Throughout any Group E structure greater than 4,000 square feet in area, which contains more than one fire area, and which is separated into two or more buildings by fire walls of less than four hour fire resistance rating without openings.
5. For public school state-funded construction projects see Section 903.2.19.

Section 903.2.4 is amended in its entirety, to read:

**903.2.4 Group F**

**903.2.4.1 Group F-1.** An automatic sprinkler system shall be provided throughout all buildings containing a Group F-1 occupancy where one of the following conditions exists:

1. A Group F-1 fire area exceeds 5,000 square feet.
2. A Group F-1 fire area is located more than three stories above grade plane.
3. The combined area of all Group F-1 fire areas on all floors, including any mezzanines, exceeds 10,000 square feet.
4. A Group F-1 occupancy used for the manufacture of upholstered furniture or mattresses exceeding 2,500 square feet (230 m<sup>2</sup>).

**903.2.4.1.1 Woodworking operations.** An automatic sprinkler system shall be provided throughout all Group F-1 occupancy fire areas that contain woodworking operations in excess of 2,500 square feet in area (232 m<sup>2</sup>) that generate finely divided combustible waste or use finely divided combustible materials. A fire

wall of less than 4-hour fire-resistance rating without openings, or any fire wall with openings, shall not be used to establish separate fire areas.

**903.2.4.2 Group F-2.** An automatic sprinkler system shall be provided throughout all buildings containing a Group F-2 occupancy greater than 5,000 square feet.

Section 903.2.7 is amended to read:

**903.2.7 Group M.** An automatic sprinkler system shall be provided throughout buildings containing a Group M occupancy where one of the following conditions exists:

1. A Group M fire area exceeds 5,000 square feet.
2. A Group M fire area is located more than three stories above grade plane.
3. The combined area of all Group M fire areas on all floors, including any mezzanines, exceeds 10,000 square feet.
4. A Group M occupancy used for the display and sale of upholstered furniture or mattresses exceeds 5,000 square feet (464 m<sup>2</sup>).
5. The structure exceeds 10,000 square feet, contains more than one fire area containing a Group M occupancy, and is separated into two or more buildings by fire walls of less than 4-hour fire-resistance rating without openings.

Section 903.2.8 is amended to read:

**903.2.8 Group R.** An automatic sprinkler system installed in accordance with Section 903.3 shall be provided throughout all Group R occupancies, including manufactured and mobile homes, including those located in mobile home parks.

Section 903.2.8.1.1 is added, to read:

**903.2.8.1.1 Group R-3 Substantial Addition or Expansion.** An automatic sprinkler system shall be provided throughout all existing Group R-3 dwellings where a substantial addition or expansion occurs and the new total fire area of the structure exceeds 3,600 square feet.

**Exception:** If a sprinkler system is required by the local building department regardless of the size of the addition or expansion, a sprinkler system shall be installed in accordance with the appropriate standard.

Section 903.2.9 is amended to read:

**903.2.9 Group S-1.** An automatic sprinkler system shall be provided throughout all buildings containing a Group S-1 occupancy where one of the following conditions exists:

1. A Group S-1 fire area exceeds 5,000 square feet.
2. A Group S-1 fire area is located more than three stories above grade plane.
3. The combined area of all Group S-1 fire areas on all floors, including any mezzanines, exceeds 10,000 square feet.
4. A Group S-1 occupancy used for the storage of upholstered furniture or mattresses exceeding 2,500 square feet (230 m<sup>2</sup>).

Section 903.2.9.1 is amended to read:

**903.2.9.1 Repair garages.** An automatic sprinkler system shall be provided throughout all buildings used as repair garages in accordance with Section 406.8 of the California Building Code, as shown:

1. Buildings having two or more stories above grade plane, including basements, with a fire area containing a repair garage exceeding 5,000 square feet.
2. Buildings not more than one story above grade plane, with a fire area containing a repair garage exceeding 5,000 square feet.
3. Buildings with repair garages servicing vehicles parked in basements.
4. A Group S-1 fire area used for the repair of commercial motor vehicles where the fire area exceeds 5,000 square feet (464 m<sup>2</sup>).

Section 903.2.10 is amended in its entirety, to read:

**903.2.10 Group S-2.**

**903.2.10.1 Group S-2 enclosed parking garages.** An automatic sprinkler system shall be provided throughout buildings classified as enclosed parking garages in accordance with Section 406.6 of the California Building Code where either of the following conditions exists:

1. Where the fire area of the enclosed parking garage exceeds 5,000 square feet.
2. Where the enclosed parking garage is located beneath other occupancy groups.

**903.2.10.2 Group S-2 Low Hazard Storage.** An automatic sprinkler system shall be provided throughout all buildings containing a Group S-2 occupancy exceeding 5,000 square feet.

Section 903.3.1.1.3 is added, to read:

**903.3.1.1.3 Undeclared Use.** In buildings of undeclared use with floor to structure height greater than 14 feet (4256 mm), the fire sprinkler system shall be designed to conform to Extra Hazard Group I design density. In buildings of undeclared use with floor to structure height less than 14 feet (4256 mm), the fire sprinkler system shall be designed to conform to Ordinary Group II design density. Where a subsequent occupancy requires a system with greater capability, it shall be the responsibility of the owner and/or the occupant to upgrade the system.

Section 903.3.1.3 is amended to read:

**903.3.1.3 Sprinkler Systems for One and Two family dwellings.** Automatic sprinkler systems for one and two- family dwellings shall be permitted to be installed in accordance with sections 903.3.1.3.1 through 903.3.1.3.3.

Sections 903.3.1.3.1, 903.3.1.3.2, and 903.3.1.3.3 are added, to read

**903.3.1.3.1 NFPA 13D Sprinkler Systems.** Automatic sprinkler systems installed in one and two family dwellings, Group R-3 buildings, and townhouses shall be permitted to be installed throughout in accordance with NFPA 13D as amended in Chapter 80.

**903.3.1.3.2 California Residential Code Section R313.** Automatic sprinkler systems shall be permitted to be installed in accordance with California Residential Code section R313.

**903.3.1.3.3 Pipe limitations.** Where CPVC pipe is installed above the insulation or is otherwise located in an unconditioned space, such as in an attic space, or a garage without conditioned living space above,

CPVC pipe shall be adequately insulated to a minimum R-19 value, or equivalent, or pipe shall be limited to Type K or L copper, or ferrous piping.

Section 903.3.5.3 is added, to read:

**903.3.5.3 Non-permissible water supply storage.** Swimming pools and ponds shall not be considered water storage for the purposes of Section 903.3.5.

Section 903.3.9 is amended to read:

**903.3.9. Floor control valves.** Individual floor control valves and waterflow detection assemblies shall be provided for each floor in multi-floor buildings at an approved location.

**Exception:** Group R-3 and R-3.1 Occupancies.

Section 903.4.2 is amended to read:

**903.4.2 Alarms.** One approved audible and visual device shall be connected to every automatic sprinkler system at an approved location. Such sprinkler water-flow alarm devices shall be activated by water flow equivalent to the flow of a single sprinkler of the smallest orifice size installed in the system. Audible and visual alarm devices shall be provided on the exterior of the building in an approved location. Where a fire alarm system is installed, actuation of the automatic sprinkler system shall actuate the building fire alarm system.

Sections 903.6.1 and 903.6.2 are added, to read:

**903.6.1 Substantial Addition or Expansion.** An automatic sprinkler system shall be provided throughout all existing buildings where a substantial addition or expansion occurs and the total fire area of the structure exceeds 5,000 square feet. Group R-3 substantial additions or expansions shall comply with Section 903.2.8.2.1

**903.6.2 Change of occupancy classification.** Any existing building that undergoes a change of occupancy classification into a higher hazard category shall comply with the requirements of Section 903.2. Relative hazard categories of occupancy groups shall be established based upon the Heights and Areas Hazard Categories of Table 1012.4 of the current edition of the International Existing Building Code, as published by the International Code Council. The requirements of Section 903.2 shall not be required when a change of occupancy classification is made to an equal or lesser hazard category. Group L occupancies shall be considered a relative hazard of 1 (highest hazard). Group R-3 occupancies shall be considered a relative hazard of 4 (lowest hazard).

Section 907.4.4 is added, to read:

**907.4.4 Monitoring of other fire systems.** In buildings equipped with a fire alarm system or sprinkler alarm and supervisory service (SASS) system, where other fire suppression or extinguishing systems are installed in the building (including but not limited to commercial kitchen suppression systems, pre-action fire suppression systems, dry chemical systems, and clean agent systems), these other suppression systems shall be monitored by the SASS dedicated function fire alarm system and transmitted as a specific signal to the Central Station. The system shall be monitored in compliance with Section 907.6.5.

Section 907.5.2.3.1 is amended to read:

ORDINANCE NO. 2016-23

**907.5.2.3.1 Public and common areas.** Visible alarm notification appliances shall be provided in public use areas and common use areas, including but not limited to:

1. Sanitary facilities including restrooms, bathrooms, shower rooms, and locker rooms.
2. Corridors, hallways, and aisles with shelving and/or fixtures obstructing the required light intensity for that area.
3. Music practice rooms.
4. Band rooms.
5. Gymnasiums.
6. Multipurpose rooms.
7. Occupational shops.
8. Occupied rooms where ambient noise impairs hearing of the fire alarm.
9. Lobbies.
10. Meeting/Conference rooms.
11. Classrooms.
12. Medical exam rooms.
13. Open office areas.
14. Sales floor areas.
15. Break or lunch rooms
16. Copy or work rooms.
17. Computer server rooms exceeding 200 sq. ft.
18. File or Storage rooms exceeding 200 sq. ft.

Section 907.6.6 is amended to read:

**907.6.6 Monitoring of fire alarm systems.** A fire alarm system required by this chapter, or by the California Building Code, shall be monitored by a UL-listed Central Station service in accordance with NFPA 72 and this code.

**Exception:** Monitoring by a UL-listed central station is not required for:

1. Single and multiple station smoke alarms required by Section 907.2.11.
2. Group I-3 occupancies shall be monitored in accordance with Section 907.2.6.3.4.
3. Residential Day Care Facilities (occupancy load of 14 or less).
4. One and two family dwellings.
5. Residential Care Facilities licensed by the state with an occupant load of 6 or less.
6. Occupancies with a local fire alarm system that will give an audible and visible signal at a constantly attended location, as approved by the Fire Code Official.

Section 907.8.6 is added, to read:

**907.8.6 Certification.** New fire alarm systems shall be UL-Certified. A Certificate of Completion and other documentation as listed in NFPA 72 shall be provided for all new fire alarm system installations. It is the responsibility of the building owner or owner's representative to obtain and maintain a current and valid Certificate.

Section 907.8.6.1 is added, to read:

**907.8.6.1 Posting of Certificate.** The UL Certificate shall be posted in a durable transparent cover within 3 feet of the fire alarm control panel within 45 days of the final acceptance test/inspection.

## Chapter 10. Means of Egress.

Section 1028.5.1 is added, to read:

**1028.5.1 Exit discharge surface.** Exterior exit pathway surfaces shall be suitable for pedestrian use in inclement weather, and shall terminate at a public way as defined in the California Building Code.

## Chapter 33. Fire Safety During Construction and Demolition.

Section 3301.3 is added, to read:

**3301.3 Permits.** Permits shall be obtained for asbestos removal operations, temporary fire department access roads for construction, and temporary water supplies as set forth in sections 105.6 and 105.7.

Section 3318 is added, to read:

### Section 3318 Asbestos removal.

**3318.1 General.** Operations involving removal of asbestos or asbestos-containing materials from buildings shall be in accordance with Section 3318.

**Exception:** Section 3318 does not apply to the removal of asbestos from:

1. Pumps, valves, gaskets and similar equipment.
2. Pipes, ducts, girders or beams that have a length less than 21 linear feet (6400 mm).
3. Wall or ceiling panels that have an area of less than 10 square feet (0.93 m<sup>2</sup>) or a dimension of less than 10 linear feet (3048 mm).
4. Floor tiles when their removal can be completed in less than four hours.
5. Group R-3 occupancies.

**3318.2 Notification.** The fire code official shall be notified 24 hours prior to the commencement and closure of asbestos-removal operations. The permit applicant shall notify the building official when asbestos abatement involves the removal of materials that were used as a feature of the building's fire resistance.

**3318.3 Plastic Film.** Plastic film that is installed on building elements shall be flame resistant as required for combustible decorative material, in accordance with Section 807.

**3318.4 Signs.** Approved signs shall be posted at the entrance, exit and exit-access door, decontamination areas, and waste disposal areas for asbestos-removal operations. The signs shall state that asbestos is being removed from the area, that asbestos is a suspected carcinogen, and that proper respiratory protection is required. Signs shall have a reflective surface. Lettering shall be a minimum of 2 inches (51 mm) high.

## Chapter 50. Hazardous Materials – General Provisions.

Section 5001.5.3 is added, to read:

**5001.5.3 Emergency response support information.** Floor plans, material safety data sheets, Hazardous Materials Management Plans (HMMP), Hazardous Material Inventory Statements (HMIS), and other information must be stored at a readily accessible location, as determined by the fire code official. This

location may be in cabinets located outside of facilities or buildings. Information may be required to be maintained in a specific electronic media format to facilitate computer aided dispatching.

Section 5003.9.1.2 is added, to read:

**5003.9.1.2 Documentation.** Evidence of compliance with provisions of this chapter as well as with state and federal hazardous material regulations shall be maintained on site and available for inspection by fire department personnel.

## **Chapter 56. Explosives and Fireworks.**

Section 5601.1.3 is amended to read:

**5601.1.3 Fireworks.** The possession, manufacture, storage, sale, handling, and use of fireworks are prohibited within the jurisdiction of the District.

**Exceptions:**

1. The use of fireworks for fireworks displays, pyrotechnics before a proximate audience, pyrotechnic special effects in motion pictures, television, theatrical, or group entertainment productions as allowed by Title 19, Division 1, Chapter 6 Fireworks reprinted in Section 5608 and the Health and Safety Code Division 11.
2. Snap Caps and Party Poppers classified by the State Fire Marshal as pyrotechnic devices.

Section 5601.2.2 is amended to read:

**5601.9 Sale and retail display.** No person shall construct a retail display or offer for sale any explosives, explosive materials, or fireworks within the jurisdiction.

**Exception:** Snap Caps and Party Poppers classified by the State Fire Marshal as pyrotechnic devices.

Section 5601.2.4 is amended as follows:

**5601.2.4 Financial responsibility.** Before a permit is issued pursuant to Section 5601.2, the applicant shall file with the jurisdiction a corporate surety bond in the principal sum of \$2,000,000 or a public liability insurance policy for the same amount, for the purpose of the payment of all damages to persons or property which arise from, or are caused by, the conduct of any act authorized by the permit upon which any judicial judgment results. The fire code official is authorized to specify a greater or lesser amount when, in his or her opinion, conditions at the location of use indicate a greater or lesser amount is required. Government entities shall be exempt from this bond requirement.

**Exception:** Fireworks in accordance with California Code of Regulations, Title 19, Division 1, Chapter 6. See Section 5608.

Section 5601.9 is added, to read:

**5601.9 Prohibited and Limited Acts.** The storage of explosive materials is prohibited in all zoning districts except districts zoned for industrial or agricultural uses. In districts where the storage of explosive materials is permitted, the quantities of explosives and distances shall be in accordance with California Fire Code Section 5601.8.

## Chapter 57. Flammable and Combustible Liquids.

Section 5704.2.9.6.1 is amended to read:

**5704.2.9.6.1 Locations where above-ground tanks are prohibited.** The storage of Class I and II liquids in above-ground tanks outside of buildings is prohibited in all zoning districts except districts zoned for commercial, industrial, or agricultural uses.

**Exception:** Protected above-ground tanks for the purpose of emergency power generator installations in areas zoned commercial, industrial, agricultural, central business district, rural or rural residential, and for facilities on an individual basis consistent with the intent of this provision. Tank size shall not exceed 500 gallons (1892.706L) for Class I or II liquids, or 1,000 gallons (3785.412L) for Class III liquids.

Section 5706.2.4.4 is amended to read:

**5706.2.4.4 Locations where above-ground tanks are prohibited.** Storage of Class I and II liquids in above-ground tanks is prohibited in all zoning districts except district zoned for commercial, industrial, or agricultural use.

## Chapter 58. Flammable Gases and Flammable Cryogenic Fluids.

Section 5806.2 is amended to read:

**5806.2 Limitation.** The storage of flammable cryogenic fluids in stationary containers outside of buildings is prohibited in any area which is zoned for other than industrial use.

**Exception:** Liquid hydrogen fuel systems in compliance with Section 5806.3 or 5806.4.

## Chapter 61. Liquefied Petroleum Gases.

Section 6103.2.1.7 is amended to read:

**6103.2.1.7 Use for food preparation.** Individual portable L-P containers used, stored, or handled inside a building classified as a Group A, Group B, or Group M occupancy for the purposes of cooking, food display, or a similar use, shall be limited in size to one quart capacity and shall be of an approved type. The number of portable containers permitted will be at the discretion of the fire code official. LP-gas appliances used for food preparation shall be listed for such use in accordance with the California Mechanical Code and NFPA 58.

Section 6104.2 is amended to read:

**6104.2 Maximum capacity within established limits.** The storage of liquefied petroleum gas is prohibited in any central business district and in all zoning districts except districts zoned for commercial, industrial, rural, or agricultural uses. The aggregate capacity of any one installation used for the storage of liquefied petroleum gas shall not exceed a water capacity of 2,000 gallons (7570 L).

## Chapter 80. Referenced Standards.

Chapter 80 is amended by adding the following referenced standards:

ORDINANCE NO. 2016-23



NFPA 3 (2015): Recommended Practice for Commissioning of Fire Protection and Life Safety Systems

NFPA 4 (2015): Standard for Integrated Fire Protection and Life Safety System Testing

NFPA 850 (2015): Recommended Practice for Fire Protection for Electric Generating Plants and High Voltage Direct Current Converter Stations

Chapter 80 is further amended by amending the NFPA 13D (2016) (Standard for the Installation of Sprinkler Systems in One- and Two-Family Dwellings and Manufactured Homes) standard as follows:

Section 7.7.1 is added, to read:

**7.7.1** Where CPVC pipe is installed above the normal insulation in an unconditioned space, such as in an attic space, or a garage without conditioned living space above, CPVC pipe shall be adequately insulated to a minimum R-19 value, or equivalent, or pipe shall be limited to Type K or L copper, or ferrous piping.

Section 8.3.5.1.2 is amended to read:

**8.3.5.1.2** Where fuel-fired equipment is below or on the same level as occupied areas of the dwelling unit, at least one quick-response intermediate temperature sprinkler shall be installed above the equipment or at the wall separating the space with the fuel-fired equipment from the occupied space. In unconditioned spaces, CPVC pipe shall be adequately insulated to a minimum R-19 value, or equivalent, or pipe shall be limited to Type K or L copper, or ferrous piping.

## **Appendix B. Fire-Flow Requirements for Buildings.**

Section B105.2 is amended by amending the exception to read:

### **Exceptions:**

1. Group B, S-2, and U occupancies having a floor area not exceeding 1,000 square feet, primarily constructed of noncombustible exterior walls with wood or steel roof framing, having a Class A roof assembly, with uses limited to the following or similar uses:
  - 1.1. California State Parks buildings of an accessory nature (restrooms).
  - 1.2. Safety roadside rest areas, (SRRA), public restrooms.
  - 1.3. Truck inspection facilities, (TIF), CHP office space and vehicle inspection bays.
  - 1.4. Sand/salt storage buildings, storage of sand and salt.
2. A reduction in required fire-flow of 50 percent, as approved by the fire code official, when the building is provided with an approved automatic sprinkler system and installed in accordance with Section 903.3.1.1. The resulting fire-flow shall be not less than 1,500 gallons per minute (5678L/min) for the prescribed duration as specified in Table B105.1.

## **Appendix C. Fire Hydrant Locations and Distribution.**

Table C102.1 is amended as follows:

The title of Table C102.1 is amended to read:

ORDINANCE NO. 2016-23

TABLE C102.1<sup>i</sup>

The heading of the fourth column of Table C102.1 is amended to read:

MAXIMUM DISTANCE FROM ANY POINT ON STREET OR ROAD FRONTAGE TO A  
HYDRANT<sup>d,f,g,h</sup>

Footnotes “h” and “i” are added to Table C102.1, to read:

- h. A fire hydrant shall be provided within 250 feet of a fire trail access point off a public or private street.
- i. For infill projects within existing single-family residential developments, Section 507.5.1 applies.

**Appendix D. Fire Apparatus Access Roads.**

Section D102.1 is amended to read:

**D102.1 Access and loading.** Facilities, buildings or portions of buildings hereafter constructed shall be accessible to fire department apparatus by way of an approved fire apparatus access road with an asphalt, concrete, or other approved all-weather driving surface capable of supporting the imposed load of fire apparatus weighing at least 74,000 pounds (33 566 kg) in accordance with CalTrans Design Standard HS-20-44.

**Exception:** Driveways serving one or two single-family dwellings may be constructed of an alternate surface material, providing the imposed weight load design minimums are met and the grade does not exceed 10 percent.

Section D103.1 is deleted.

Section D103.2 is amended to read:

**D103.2 Grade.** Fire department access roadways having a grade of between 16 percent and 20 percent shall be designed to have a finished surface of grooved concrete sufficient to hold a 44,000 pound (19 958 kg) traction load. The grooves in the concrete surface shall be ½ inch (13 mm) wide by ½ inch (13 mm) deep and 1 ½ inch (38 mm) on center and set at a 30 to 45 degree angle across the width of the roadway surface. No grade shall exceed 20 percent, nor shall the cross slope exceed 8%, unless authorized in writing by the fire code official.

Section D103.2.1 is added, to read:

**D103.2.1 Angles of approach and departure.** The angles of approach and departure for any means of access shall not exceed 10 percent at 10 feet of the grade break.

Section D103.3 is amended to read:

**D103.3 Turning radius.** Based on a minimum unobstructed width of 20 feet, a fire apparatus access roadway shall be capable of providing a minimum standard turning radius of 25 feet (7620 mm) inside and 45 feet (13 716 mm) outside.

ORDINANCE CONTINUES ON NEXT PAGE

Table D103.4 is amended to read:

**Table D103.4**  
**REQUIREMENTS FOR DEAD-END FIRE**  
**APPARATUS ACCESS ROADS**

LENGTH (feet)	MINIMUM WIDTH (feet)	TURNAROUNDS REQUIRED
0 – 150	20 <sup>a</sup>	None required
151 – 750	20 <sup>a</sup>	100-foot Hammerhead, 50-foot “Y”, 75-foot Shunt or 90-foot-diameter cul-de-sac in accordance with figure D103.1
Over 750	Special approval required <sup>b</sup>	

- a. A driveway with a minimum width of 16 feet is acceptable for access to no more than two single-family dwellings.
- b. Any fire apparatus access roadway or driveway that is approved to be less than 20 feet wide and to exceed 750 feet in length shall have outsets or turnouts every 300 feet along the length of the road or driveway, or at locations approved by the fire code official. Each outset or turnout shall be of the following dimensions: an 8 foot wide turnout that extends at least 40 feet in length.

Figure D103.1 is amended to read:

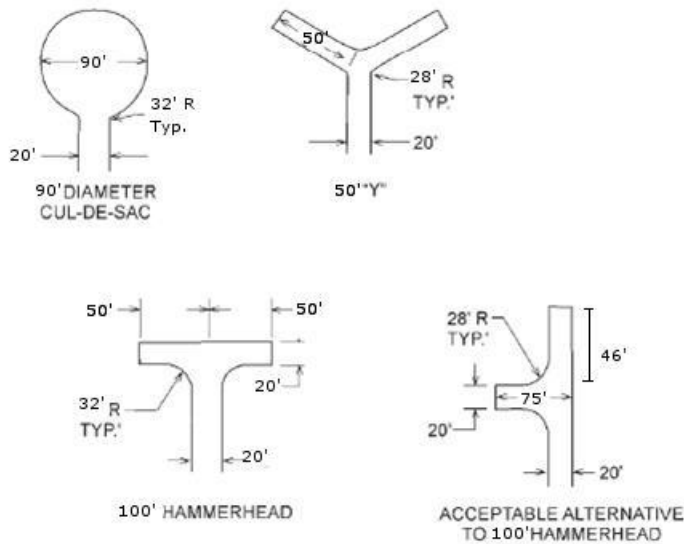

**Figure D103.1**  
**Dead-end Fire Apparatus Access Road Turnaround**

Section D103.5 is amended as follows:

Criteria 1 of Section D103.5 is amended to read:

1. The minimum clear width shall be 20 feet (6096mm).

**Exception:** For access to one or two single-family dwellings, 16 feet clear width is acceptable.

Criteria 9 is added to Section D103.5, to read:

9. All gates shall be installed and located a minimum of 30 feet off the street.

Section D103.6.1 is amended to read:

**D103.6.1 Roads less than 28 feet in width.** Fire apparatus access roads less than 28 feet wide shall be posted on both sides as a fire lane.

Section D103.6.2 is amended to read:

**D103.6.2 Roads 28 feet in width or greater, but less than 36 feet in width.** Fire apparatus access roads 28 feet wide or greater, but less than 36 feet wide, shall be posted on one side of the road as a fire lane.

Section D106.1 is amended by deleting the exception and to read:

**D106.1 Projects having more than 100 dwelling units.** Multiple-family residential projects having more than 100 dwelling units shall be provided with two separate and approved fire apparatus access roads and shall meet the requirements of Section D104.3.

Section D106.2 is deleted in its entirety.

### SECTION 3. REPEAL OF FIRE CODE.

Ordinance No. 2013-22, adopting the 2013 California Fire Code with amendments, is hereby repealed.

### SECTION 4. REFERENCES TO PRIOR CODE.

Unless superseded and expressly repealed, references in City forms, documents, and regulations to the chapters and sections of the Fire Code of Contra Costa County, the Crockett-Carquinez Fire Protection District, and the Contra Costa County Fire Protection District, 2013, shall be construed to apply to the corresponding provisions contained within the Fire Code of Contra Costa County, the Crockett-Carquinez Fire Protection District, and the Contra Costa County Fire Protection District, 2016. Ordinance 2013-22 and all other ordinances or parts of ordinances in conflict herewith are hereby superseded and expressly repealed.

### SECTION 5. VALIDITY.

The Contra Costa County Board of Supervisors declares that if any section, paragraph, sentence, or word of this ordinance or of the 2016 California Fire Code as adopted and amended herein is declared for any reason to be invalid, it is the intent of the Contra Costa County Board of Supervisors that it would have passed all other portions or provisions of this ordinance independent of the elimination here from any portion or provision as may be declared invalid.

SECTION 6. MORE RESTRICTIVE REQUIREMENTS.

If requirements more restrictive than those in this fire code are adopted by the city of Antioch, Clayton, Concord, Lafayette, Martinez, Pittsburg, Pleasant Hill, San Pablo, or Walnut Creek, or the County of Contra Costa, those requirements will apply only within the jurisdiction adopting those requirements.

SECTION 7. EFFECTIVE DATE.

This ordinance becomes effective on January 1, 2017 or 30 days after passage, whichever is later. Within 15 days of passage, this ordinance shall be published once in the Contra Costa Times, a newspaper published in this County. This ordinance shall be published in a manner satisfying the requirements of Government Code Section 25124, with the names of supervisors voting for and against it.

Passed on \_\_\_\_\_, by the following vote:

- AYES:
- NOES:
- ABSENT:
- ABSTAIN:

ATTEST: David Twa,  
Clerk of the Board of Supervisors  
and County Administrator

\_\_\_\_\_  
Board Chair

By: \_\_\_\_\_  
Deputy

[SEAL]

KCK:  
H:\FPD\2016\Fire Code Ord\Ordinance No. 2016-23 Fire Code Adoption Ord - final.docx

ORDINANCE NO. 2016-23

FIRE CODE

ORDINANCES OF THE COUNTY OF CONTRA COSTA, THE CROCKETT-CARQUINEZ FIRE PROTECTION DISTRICT, AND THE CONTRA COSTA COUNTY FIRE PROTECTION DISTRICT ADOPTING THE 2016 CALIFORNIA FIRE CODE WITH AMENDMENTS.

The Contra Costa County Board of Supervisors, as the Board of Supervisors for Contra Costa County and as the Board of Directors of the Crockett-Carquinez Fire Protection District and the Contra Costa County Fire Protection District, ordains as follows:

SECTION 1. ADOPTION OF THE CALIFORNIA FIRE CODE.

Contra Costa County, the Crockett-Carquinez Fire Protection District, and the Contra Costa County Fire Protection District hereby adopt the 2016 California Fire Code (California Code of Regulations, Title 24, Part, 9 [based on the 2015 International Fire Code published by the International Code Council]), including Chapters 1-10 and 12-80, Appendix B, Appendix C, Appendix D, Appendix F, Appendix H, Appendix I, Appendix J, and Appendix K, as amended by the changes, additions, and deletions set forth in this ordinance. The 2016 California Fire Code, with the changes, additions, and deletions set forth this ordinance, is adopted by this reference as though fully set forth in this ordinance. As of the effective date of this ordinance, the provisions of the fire code are controlling and enforceable within the limits of each jurisdiction.

SECTION 2. AMENDMENTS TO THE CALIFORNIA FIRE CODE.

The 2016 California Fire Code is amended by the changes, additions, and deletions set forth in this Section 2. Chapter and Section numbers used below are those of the 2016 California Fire Code.

**Chapter 1. Scope and Administration.**

Section 101.1 is amended to read:

**101.1 Title.** This code is the Fire Code of Contra Costa County, the Crockett-Carquinez Fire Protection District, and the Contra Costa County Fire Protection District, and is hereinafter referred to as “this code.”

Section 102.1 is amended to add item 5, to read:

5. Where not otherwise limited by law, the provisions of this code shall apply to vehicles, ships, and boats that are permanently affixed to a specific location within the boundaries of this jurisdiction.

Section 105.6 is amended to read:

**105.6 Required operational permits.** The fire code official is authorized to issue operational permits for the operations set forth in Chapter 1, Sections 105.6.1 through 105.6.60.

Section 105.6.5 is amended to read:

**105.6.5 Carnivals, Fairs, Festivals and Exhibitions.** A permit is required to operate a carnival, fair, festival, or exhibition.

Section 105.6.31 is amended to read:

**105.6.31 Motor Fuel Dispensing Facilities.** An operational permit is required for the operation of automotive, marine, and fleet motor fuel dispensing facilities, as well as for sites that allow mobile fueling from a service provider to the general public.

Section 105.6 is amended by adding subsections 105.6.50 through 105.6.60, to read:

**105.6.50 Asbestos removal.** A permit is required to conduct asbestos-removal operations regulated by Section 3318.

**105.6.51 Automobile Wrecking or Dismantling Yard.** An operation permit is required for all automobile wrecking yards, automobile dismantling operations, and similar operations.

**105.6.52 Battery systems.** A permit is required to operate stationary lead-acid battery systems having a liquid capacity of more than 50 gallons (189 L) pursuant to Section 608.

**105.6.53 Christmas tree sales.** A permit is required to use a property for the purpose of selling cut Christmas trees.

**105.6.54 Emergency Responder Radio Coverage.** A permit is required for facilities with Emergency Responder Radio Coverage Systems.

**105.6.55 Firework aerial display.** A permit is required to conduct a firework display regulated by California Code of Regulations, Title 19 and Chapter 56 of this code.

**105.6.56 Model rockets.** A permit is required to sell model rocket motors or launch model rockets (in excess of 3 launches per event) pursuant to California Code of Regulations, Title 19, Division 1, Article 17. Permits issued in accordance with this section are for the site, and are effective as long as site conditions have not changed.

**105.6.57 Temporary water supply.** A permit is required to use a temporary water supply for construction of residential projects or subdivisions pursuant to Section 3312.1.

**105.6.58 Tire storage.** A permit is required to store more than 1,000 cubic feet (28.3m<sup>3</sup>) of tires inside buildings pursuant to Chapter 34.

**105.6.59 Oil Extraction Process.** A permit is required to operate a process that uses a volatile solvent or Liquid Carbon Dioxide to extract oil from organic material.

**105.6.60 Indoor Growing Operation.** A permit is required to operate an indoor growing operation.

**Exception:** Agricultural Greenhouses in an agricultural zone.

Section 105.7 is amended to read:

**105.7 Required construction permits.** The fire code official is authorized to issue construction permits for the operations set forth in Chapter 1, Sections 105.7.1 through 105.7.21.



Section 105.7 is amended by adding Sections 105.7.17 through 105.7.22, to read:

**105.7.17 Access for fire apparatus.** Plans shall be submitted and a permit is required to install, improve, modify, or remove public or private roadways, driveways, and bridges for which Fire District access is required by the Fire Code. A permit is required to install a gate across a fire apparatus access road pursuant to Section 503.

**105.7.18 Construction, alteration, or renovation of a building for which a building permit is required.** Plans shall be submitted to the fire code official for all land developments or for the construction, alteration, or renovation of a building within the jurisdiction where a building permit is required.

**Exception:** Non-sprinklered Group R-3 Occupancies where work does not involve a substantial addition or expansion.

**105.7.19 Medical gas systems.** A construction permit is required for the installation of or modification to a medical gas system pursuant to Section 5306.

**105.7.20 Refrigeration equipment.** A permit is required to install a mechanical refrigeration unit or system regulated by Chapter 6 and/or the California Mechanical Code.

**105.7.21 Land Development, Subdivisions.** Plans shall be submitted to the fire code official for all land developments or improvements proposed within the jurisdiction that involve the subdivision of land.

**105.7.22 Water supply for fire protection.** Plans shall be submitted to the fire code official for the purpose of determining whether adequate water supplies, fire hydrants, and associated systems are provided for all facilities, buildings, or portions of buildings either constructed or moved into the District pursuant to Section 507.

Section 105.8 is added, to read:

**105.8 Responsibility of permittee.** Construction permits shall be presumed by the Fire District to incorporate all of the work that the applicant or the applicant's agent, employees, or contractors shall carry out. Work performed shall be in accordance with the approved plans and with all requirements of this code and any other laws or regulations applicable thereto. No Fire District approval shall relieve or exonerate any person from the responsibility of complying with the provisions of this code nor shall any vested rights be created for any work performed in violation of this code.

Section 108.1 is amended to read:

**108.1 Board of Appeals established.** In order to hear and decide appeals of orders, decisions, or determinations made by the fire code official relative to the application and interpretation of this code, there is hereby created a board of appeals. The board of appeals is comprised of the Board of Directors.

Section 108.3 is deleted.

Section 109.4 is amended to read:

**109.4 Violation penalties.** Every person who violates any provision of this fire code is guilty of an infraction or misdemeanor in accordance with Health and Safety Code Section 13871 and Government Code Section 53069.4. The imposition of one penalty for any violation shall not excuse the violation or

permit it to continue; and all such persons shall be required to correct or remedy such violations or defects within a reasonable time; and when not otherwise specified, each ten (10) days that prohibited conditions are maintained shall constitute a separate offense. The application of the aforesaid penalty shall not be held to prevent the enforced removal of prohibited conditions.

Section 111.4 is amended to read:

**111.4 Failure to comply.** Any person who continues any work after having been served with a stop work order is subject to citation, except any work that a person is directed by the fire code official to perform to remove a violation or unsafe condition.

## **Chapter 2. Definitions.**

Section 202 is amended by adding the following definitions to that section:

**Administrator.** Fire Chief.

**All-weather driving surface.** A roadway with a minimum surface finish of one layer of asphalt or concrete that is designed to carry the imposed weight loads of fire apparatus.

**Automobile Dismantling.** The operation of dismantling or removing parts from salvaged vehicles including engines or engine parts.

**Automobile Wrecking Yard.** An area that stores or dismantles salvaged vehicles.

**Board of Directors.** The Contra Costa County Board of Supervisors as the governing body of the Crockett-Carquinez Fire Protection District and the Contra Costa County Fire Protection District.

**Board of Fire Commissioners.** An advisory commission appointed by the Board of Directors to act as set forth in this ordinance and by resolutions of the Board of Directors.

**Cost of Abatement.** Includes all expenses incurred by the jurisdiction in its work of abatement and administrative costs pursuant to Section 319.5 of this code.

**Defensible Space.** The area within the perimeter of a parcel providing the key point of defense from an approaching wildland or escaping structure fire.

**Driveway.** A private roadway that provides access to no more than two (2) single-family dwellings.

**Fire Code Official.** In the Contra Costa County Fire Protection District, the Fire Code Official is the Fire Marshal. In the Crockett-Carquinez Fire Protection District, the Fire Code Official is the Fire Chief.

**Firebreak.** A continuous strip of land upon and from which all rubbish, weeds, grass, or other growth that could be expected to burn has been abated or otherwise removed in order to prevent extension of fire from one area to another.

**Firetrail.** A graded firebreak of sufficient width, surface, and design to provide access for personnel and equipment to suppress and to assist in preventing a surface extension of fires.

**Nuisance Fire Alarm.** The activation of any fire protection or alarm system which results in the response of the Fire District and is caused by malfunction, improper maintenance, negligence, or misuse of the system by an owner, occupant, employee, or agent, or any other activation not caused by excessive heat, smoke, fire, or similar activating event.

**Person.** Includes individuals, firms, partnerships, and corporations.

**Priority Hazard Zone.** An area where the threat from wildfire is severe due to proximity to open space, topography, degree of space, density of homes and/or amount of vegetation (native and ornamental), and/or other conditions favorable to fast moving fires.

**Reduced Fuel Zone.** The area that extends from thirty (30) feet to one hundred (100) feet away from the structure, or to the property line, whichever is closer to the structure.

**Response time.** The elapsed time from receipt of call to the arrival of the first unit on scene.

**Rubbish.** Waste matter, litter, trash, refuse, debris, and dirt on streets or private property in the jurisdiction which is, or when dry may become, a fire hazard.

**Rural area.** An area generally designated for agricultural or open space uses with parcels more than 10 acres (4.046873ha) in size.

**Rural residential area.** An area generally designated for single family residential use with parcels between three (1.2140619ha) and 10 (4.046873ha) acres in size.

**Running time.** The calculated time difference between leaving the first-due station and arriving on the emergency scene.

**Sprinkler Alarm and Supervisory System (SASS).** A Dedicated Function Fire Alarm System located at the protected premise installed specifically to monitor sprinkler water-flow alarm, valve supervisory, and general trouble conditions where a Building Fire Alarm is not required.

**Streets.** Includes alleys, parkways, driveways, sidewalks, and areas between sidewalks and curbs, highways, public right of ways, private road, trails, easements, and fire trails.

**Substantial Addition or Expansion.** Addition, expansion, remodel, or renovation of any structure where the addition of new fire area exceeds fifty percent of the existing fire area. For the purposes of this definition, areas of a building in which construction elements including walls and roof assemblies were demolished and rebuilt are considered new fire area.

**Temporary fire department access road for construction.** An approved temporary roadway for emergency vehicle use during construction of residential subdivision projects.

**Temporary fire department access road for construction of one (1) residential (R3) unit.** A temporary roadway for emergency vehicle use during construction of an individual residential (R3) structure where a fire department access road is required as part of the project.

**Temporary water supply.** Water stored for firefighting purposes in an approved aboveground tank during combustible construction.

**Tree litter.** Any limbs, bark, branches, and/or leaves in contact with other vegetation or left to gather on the ground.

**Weeds.** All weeds growing upon streets or private property in the jurisdiction, including any of the following:

1. Weeds that bear seeds of a fluffy nature or are subject to flight.
2. Sagebrush, chaparral (including Chamise, Coyote Brush/Greasewood, Brooms, and Buckwheat), and any other brush or weeds that attain such large growth as to become, when dry, a fire menace to adjacent improved property.
3. Weeds that are otherwise noxious or dangerous.
4. Poison oak and poison sumac when the conditions of growth constitute a menace to public health.
5. Dry grass, brush, tree litter, litter, or other flammable materials that endanger the public safety by creating a fire hazard.

### **Chapter 3. General Precautions Against Fire.**

Section 304.1.2 is amended to read:

**304.1.2 Vegetation.** Hazards created by the growth of weeds, grass, vines, trees, or other growth capable of being ignited and endangering property shall be mitigated in accordance with Section 320.

Section 304.1.4 is added, to read:

**304.1.4 Clothes Dryers.** Clothes dryers shall be frequently cleaned to maintain the lint trap, mechanical and heating components, vent duct, and associated equipment free from accumulations of lint and combustible materials.

Section 308.1.4, Exception 1 is amended to read:

**Exception 1.** Residential Occupancies.

Section 320 is added to Chapter 3, to read:

### **SECTION 320 Exterior Fire Hazard Control.**

#### **320.1 General.**

**320.1.1 Jurisdictional Authority.** The Board of Directors, as the supervising, legislative, and executive authority of the jurisdiction, hereby delegates to the Board of Fire Commissioners of the jurisdiction all its powers, duties, and rights to act pursuant to Part 5 (commencing with Section 14875), Division 12, of the Health and Safety Code, to clear or order the clearing of rubbish, litter, or other flammable material where such flammable material endangers the public the safety by creating a fire hazard. Fire hazard abatement will be conducted in accordance with the provisions of said Part 5 and this ordinance. In the application of the provisions of said Part 5 to fire hazard abatement proceedings under this ordinance and the Fire Protection District Law of 1987, the terms "Board of Directors" or "Board," when used in Part 5, means the Board of Fire Commissioners of this jurisdiction under this section; and the officers designated in Health and Safety Code Section 14890 are the employees of the jurisdiction.

**320.1.2 Retention of Jurisdictional Authority.** If no Board of Fire Commissioners has been appointed for the jurisdiction, then the Board of Directors retains its powers and rights to act pursuant to said Part 5.

**320.1.3 Contract for Services.** The Board of Directors reserves and retains the power to award a contract for fire hazard abatement work when the employees of the jurisdiction are not used to perform the abatement work.

**320.2 Definitions.** The following terms are defined in Chapter 2:

**Cost of Abatement**  
**Defensible Space**  
**Person**  
**Priority Hazard Zone**  
**Reduced Fuel Zone**  
**Rubbish**  
**Streets**  
**Weeds**

**320.3 Weeds and Rubbish a Public Nuisance.** The Board hereby declares that all weeds growing upon private property or streets in this jurisdiction and all rubbish on private property or streets in this jurisdiction are public nuisances. Such weed nuisance is seasonal and recurrent.

**320.4 Abatement of Hazard.**

**320.4.1 Prohibition.** No person who has any ownership or possessory interest in or control of parcel of land shall allow to exist thereon any hazardous rubbish, weeds, trees, or other vegetation that constitutes a fire hazard. Destruction by burning within this jurisdiction is unlawful unless the written permission of the fire chief is first obtained, and all other applicable permits are obtained from appropriate governing agencies or jurisdictions.

**320.4.2 Specific Requirements.** The District shall develop minimum abatement standards for land in residential, rural and/or rural residential, business, industrial areas, or land which is unused or vacant. Such standards may be modified periodically as circumstances dictate.

**320.4.2.1 Clearance of Weeds from Streets.** The Fire Code Official is authorized to cause areas within 10 feet (3048 mm) on each side of portions of streets which are improved, designed, or ordinarily used for vehicular traffic to be cleared of flammable vegetation and other combustible growth. The Fire Code Official is authorized to enter upon private property to do so, to the extent allowed by law.

**320.5 Abatement Procedures.**

**320.5.1 Abatement Order.** The fire code official may order the abatement of the weeds and rubbish described in Sections 304.1.2 and this Section 320. On making the order, the fire code official will mail a copy of a notice to the owners of the affected property as their names and addresses appear upon the last county equalized assessment roll, or as their names and addresses are known to the fire code official. As an alternative to mailing, the notice may be posted upon the affected property and published in the jurisdiction, not less than 15 days prior to the date of the abatement hearing. Copies of the notice will be

headed with the words "Notice to Abate Weeds and Rubbish" in letters at least one inch high. The notice will be in substantially the following form:

#### NOTICE TO ABATE WEEDS AND RUBBISH

You are hereby notified that weeds and rubbish constitute a fire hazard on the following described property owned by you:

(Describe property by common street designation, by metes and bounds, Assessor's code area and parcel number, or by reference to attached map).

You must remove the weeds and rubbish within fifteen (15) days from the date of this notice. If you fail to do so, the (jurisdiction) Fire Protection District will remove it, and the cost of the abatement, including administrative costs, will be collected as property taxes and will be a lien on your property until paid.

You are further notified that the Board of Supervisors has declared that such weeds and rubbish constitute a public nuisance and that such weeds also constitute a seasonal and recurring nuisance.

You may appear before the Board of Fire Commissioners of this jurisdiction on (time and date) at (place-room, street, address, and city) to show cause why this order should not be enforced.

(Signed): (Name of fire code official or name of jurisdiction)

**320.5.2 Hearing Date.** A date for hearing on the notice will be sent at least 15 days after the date of the notice. The date of the notice is the date on which the notice is placed in the United States mail or the date on which it is posted on the property. At the hearing, the property owner or his agent may appear to show cause why the order should not be enforced. For good cause shown, the Board of Fire Commissioners may extend the time for compliance with the order or may rescind the order.

**320.5.3 Contract Award.** If the owner fails to comply with the order, the fire code official may have the weeds and rubbish abated either by employees of this jurisdiction or by contract. If a contract is awarded, it will be by public bid, awarded to the lowest responsible bidder. A contract may include work on more than one parcel. Concerning any contract previously awarded as provided in this subsection and that has been fully extended as provided in that contract, it may thereafter be extended on its same terms and conditions for a further period (not to exceed one year) by agreement of the Board of Supervisors and the involved contractor.

**320.5.4 Abatement Report of Costs.** The fire code official or his or her designee abating the nuisance will keep an account of the cost of abatement in front of or on each separate parcel of land and will render an itemized report in writing to the Board of Fire Commissioners showing the cost of removing the weeds and rubbish on or in front of each separate lot or parcel of land, or both. Before the report is submitted to the Board of Fire Commissioners, a copy of it will be posted for at least three days on or near the chamber door of the Board with a notice of the time and when the report will be submitted to the Board for confirmation. At the time fixed for receiving and considering the report, the Board of Fire Commissioners will hear it and any objections of any of the property owners liable to be assessed for the work of abatement. Thereupon, the Board of Fire Commissioners may make such modifications in the report as it deems necessary, after which the report will be confirmed. The amount of the cost, including administrative costs, of abating the nuisance in front of or upon the various parcels of the land mentioned in the report as confirmed will constitute special assessment against the respective parcels of land, and are a lien on the property for the

amount of the respective assessments. Such lien attaches upon recordation, in the office of the County Recorder, of a certified copy of the Resolution of Confirmation.

**320.5.5 Cost Assessments.** Upon confirmation of the report of cost by the Board of Fire Commissioners and the recordation of the Resolution of Confirmation, a copy of the report of cost will be sent to the County Auditor, who will enter the amount of the assessments against the parcels. Thereafter the amount of the assessments will be collected at the same time and in the same way as County taxes are collected. The owners are subject to the same penalties and the same procedure and sale in case of delinquency as provided for ordinary county taxes. All laws applicable to the levy, collection, and enforcement of county taxes are applicable to these assessment taxes.

**320.6 Alternate Mitigation.** In lieu of ordering abatement as provided in Section 320.5.1, the fire code official of this jurisdiction may order the preparation of firebreaks/fuelbreaks around parcels of property where combustible weeds, crops, or brush are present. In determining the proper width for firebreaks/fuelbreaks, the fire code official will consider the height of the growth, weather condition, topography, and the accessibility to the property for fire protection equipment. The procedure set forth in Section 320.5.1 for the abatement of weeds and rubbish shall apply to the preparation of firebreaks/fuelbreaks.

### **320.7 Subsurface Fires.**

**320.7.1 Peat Fire.** It is the duty of each person, firm, corporation, or association not to permit a peat fire or a fire involving combustible vegetable matters under the surface of the natural ground to remain upon the property. It is hereby declared that it is the duty of any person as herein defined to take all necessary precautions to extinguish any subsurface fire involving peat or vegetable material at the owner's own cost and expense.

**320.7.2 Fire Suppression Costs.** If there exists upon the lands or property of any person as herein defined a subsurface fire involving the burning or combustion of peat, vegetable matter, or vegetation, and the owner or occupant thereof has not taken reasonable precautions within a reasonable time to extinguish or minimize such fire or combustion, this jurisdiction may, in addition to its regular duties to extinguish or minimize such fire or combustion, go upon the lands of any person as herein defined and extinguish such fire or combustion. Any costs incurred by the Fire District in fighting the fire and for the cost of proving rescue or emergency medical services shall be a charge against the property owner. The charge shall constitute a debt of the property owner and is collectable by the jurisdiction incurring those costs in the same manner as in the case of an obligation under a contract, express or implied. (See Health and Safety Code, §13009.)

Section 321 is added to Chapter 3, to read:

### **321 Automobile Wrecking Yards.**

**321.1 General.** The operation of automobile wrecking yards shall be in accordance with this section.

**321.2 Definitions.** The following terms are defined in Chapter 2:

**Automobile Dismantling**  
**Automobile Wrecking Yard**

### **321.3 Requirements.**

**321.3.1 Permits.** An operational fire code permit is required as in Section 105.6.51.

**321.3.2 Fire Apparatus Access Roads.** Fire apparatus access roads shall be constructed throughout the site in accordance with this code and shall be maintained clear of all vehicles and stored items.

**321.3.3 Welding and cutting.** Welding and cutting operations shall be conducted in an approved location, clear of all flammable liquids and combustible materials, including weeds, tires, and all other debris.

**321.3.4 Housekeeping.** Combustible rubbish accumulated on site shall be collected and stored in approved containers, rooms, or vaults of noncombustible materials. Combustible vegetation, cut or uncut, shall be removed when determined by the fire code official to be a fire hazard.

**321.3.5 Fire Protection.** Offices, storage buildings, and vehicles used for site operations shall each be provided with at least one portable fire extinguisher with not less than a 4-A: 40-B-C rating. When required by the fire code official, additional fire extinguishers shall be provided.

**321.3.6 Tire storage.** Tires shall be stored in racks or in a manner as approved by the fire code official.

**321.3.6.1 Distance from Water Supply.** Tire storage shall be located on-site and no further than 500 feet from a fire hydrant or an approved water supply as determined by the fire code official.

**321.3.7 Storage Piles.** Storage piles shall be located a minimum of 20 feet from property lines and shall have an unobstructed access road on all sides of not less than 20 feet.

**321.3.8 Burning operations.** The burning of salvaged vehicles and salvaged or waste materials is prohibited.

**321.3.9 Motor vehicle fluids.** Motor vehicle fluid shall be drained from salvaged vehicles when such liquids are leaking onto the ground and prior to dismantling or removing engine/motor parts.

**321.3.9.1 Mitigation of leaking fluids.** Precautions shall be taken to prevent fluids from salvaged vehicles from leaking onto the ground. Supplies or equipment capable of mitigating leaks from fuel tanks, crankcases, brake systems, and transmissions shall be kept available on site. Single-use plugs, diking, and absorbent materials shall be disposed of as hazardous waste and removed from the site in a manner in accordance with federal, state, and local requirements.

**321.3.10 Fuel tanks.** Fuel tanks of salvaged vehicles shall be emptied of all flammable (gasoline, diesel) fuels in an approved manner and stored in approved tanks.

**321.3.10.1 Repair of vehicle fuel tanks.** The repair of fuel tanks, including cutting, welding, or drilling of any kind, is prohibited.

**321.3.11 Lead acid batteries.** Lead acid batteries shall be removed from all salvaged vehicles and stored in an approved manner in a location approved by the fire code official.

## **Chapter 4. Emergency Planning and Preparedness.**



Section 401.5.1 is added, to read:

**401.5.1 Nuisance Fire Alarm Fee.** A fee may be charged for false and/or nuisance fire alarms in accordance with a fee schedule adopted by the Board of Directors.

Section 403.12.1 is amended to read:

**403.12.1 Standby Personnel.** Where, in the opinion of the fire code official or Fire Chief, it is essential for public safety in a place of assembly, or any other place where people congregate, because of the number of persons, or the nature of the performance, exhibition, display, contest, or activity, the owner, agent, or lessee shall provide standby personnel as required and approved by the fire code official or Fire Chief. If the activity requires fire watch, fire watch shall be provided in accordance with Sections 403.12.1.1 and 403.12.1.2. Standby personnel needed for EMS standby shall be provided in accordance with Contra Costa County EMS Protocols.

## **Chapter 5. Fire Service Features.**

Section 503.1.4 is added, to read:

**503.1.4 Access to Open Spaces.** When existing access to open land or space, or to fire trail systems maintained for public or private use, is obstructed by new development of any kind, the developer shall provide an alternate means of access into the area that is sufficient to allow access for fire personnel and apparatus. The alternate means of access must be approved by the fire code official.

Section 503.2.1 is amended by adding the following exception:

**Exception:** A minimum 16 foot wide driveway is acceptable for access to one or two single-family dwellings.

Section 505.3 is added, to read:

**505.3 Street names and addressing.** Street names and addressing shall be submitted for review and approval to the fire code official, whose approval will not be unreasonably withheld. The purpose of the review is to verify that new street names and addressing will not duplicate existing street names and addressing.

Section 507.2.3 is added, to read:

**507.2.3 Suburban and rural water supply storage.** Swimming pools and ponds shall not be considered water storage for the purposes of Section 507.1.

## **Chapter 6. Building Services and Systems.**

Section 603.6.6 is added, to read:

**603.6.6 Sparks from chimneys.** A chimney that is used with either a fireplace or heating appliances in which solid or liquid fuel is used shall be maintained with spark arresters that are required for incinerators pursuant to the 2016 California Mechanical Code.

## Chapter 8. Interior Finish, Decorative Materials and Furnishings.

Section 806.1.4 is added, to read:

**806.1.4 Flame retardants.** Cut trees shall be treated by a California State Fire Marshal-licensed fire retardant applicator. Trees shall be properly treated with an approved flame retardant.

Section 806.1.5 is added, to read:

**806.1.5 Tags.** Trees shall bear a tag stating date of placement in the public building, type of flame-retardant treatment used, name of the person who applied the flame retardant, the name of the person affixing the tag, a permit expiration date, and the name of the designated individual making daily tests.

Section 806.1.6 is added, to read:

**806.1.6 Daily tests.** Trees shall be tested daily by a designated individual. The test shall include a check for dryness in accordance with Section 806.1.3 and for adequate watering.

## Chapter 9. Fire Protection Systems.

Section 901.6.2 is amended to read:

**901.6.2 Records.** Records of all system inspections, tests, and maintenance required by the reference standards shall be maintained in paper form and/or by a third party electronic record keeping service as chosen by the fire district.

Section 902 is amended to add:

### **Substantial Addition or Expansion**

Section 903.2.1.1 is amended to read:

**903.2.1.1 Group A-1.** An automatic sprinkler system shall be provided for fire areas containing Group A-1 occupancies and intervening floors of the building where one of the following conditions exists:

1. The fire area exceeds 5,000 square feet.
2. The fire area has an occupant load of 300 or more.
3. The fire area is located on a floor other than a level of exit discharge serving such occupancies.
4. The fire area contains a multi-theater complex.

Section 903.2.1.3 is amended to read:

**903.2.1.3 Group A-3.** An automatic sprinkler system shall be provided for fire areas containing Group A-3 occupancies and intervening floors of the building where one of the following conditions exists:

1. The fire area exceeds 5,000 square feet.
2. The fire area has an occupant load of 300 or more.
3. The fire area is located on a floor other than a level of exit discharge serving such occupancies.
4. The structure exceeds 10,000 square feet, contains more than one fire area containing exhibition and display rooms, and is separated into two or more buildings by fire walls of less than four hour fire resistance rating without openings.

Section 903.2.1.4 is amended to read:

**903.2.1.4 Group A-4.** An automatic sprinkler system shall be provided for fire areas containing Group A-4 occupancies and intervening floors of the building where one of the following conditions exists:

1. The fire area exceeds 5,000 square feet
2. The fire area has an occupant load of 300 or more.
3. The fire area is located on a floor other than a level of exit discharge serving such occupancies.

Section 903.2.1.8 is amended to read:

**903.2.1.8 Group B.** An automatic sprinkler system shall be provided for Group B occupancies where the fire area exceeds 5,000 square feet.

Section 903.2.3 is amended to read:

**903.2.3 Group E.** An automatic sprinkler system shall be provided for new Group E occupancies as follows:

1. Throughout all Group E fire areas greater than 2,000 square feet in area.  
**Exception:** An automatic sprinkler system is not required in any Group E Day Care Facility less than 5,000 square feet
2. Throughout every portion of educational buildings below the lowest level of exit discharge serving that portion of the building.  
**Exception:** An automatic sprinkler system is not required in any area below the lowest level of exit discharge serving that area where every classroom throughout the building has at least one exterior exit door at ground level.
3. In rooms or areas with special hazards such as laboratories, vocational shops, and other such areas where hazardous materials in quantities not exceeding the maximum allowable quantity are used or stored.
4. Throughout any Group E structure greater than 4,000 square feet in area, which contains more than one fire area, and which is separated into two or more buildings by fire walls of less than four hour fire resistance rating without openings.
5. For public school state-funded construction projects see Section 903.2.19.

Section 903.2.4 is amended in its entirety, to read:

#### **903.2.4 Group F**

**903.2.4.1 Group F-1.** An automatic sprinkler system shall be provided throughout all buildings containing a Group F-1 occupancy where one of the following conditions exists:

1. A Group F-1 fire area exceeds 5,000 square feet.
2. A Group F-1 fire area is located more than three stories above grade plane.
3. The combined area of all Group F-1 fire areas on all floors, including any mezzanines, exceeds 10,000 square feet.
4. A Group F-1 occupancy used for the manufacture of upholstered furniture or mattresses exceeding 2,500 square feet (230 m<sup>2</sup>).

**903.2.4.1.1 Woodworking operations.** An automatic sprinkler system shall be provided throughout all Group F-1 occupancy fire areas that contain woodworking operations in excess of 2,500 square feet in area (232 m<sup>2</sup>) that generate finely divided combustible waste or use finely divided combustible materials. A fire

wall of less than 4-hour fire-resistance rating without openings, or any fire wall with openings, shall not be used to establish separate fire areas.

**903.2.4.2 Group F-2.** An automatic sprinkler system shall be provided throughout all buildings containing a Group F-2 occupancy greater than 5,000 square feet.

Section 903.2.7 is amended to read:

**903.2.7 Group M.** An automatic sprinkler system shall be provided throughout buildings containing a Group M occupancy where one of the following conditions exists:

1. A Group M fire area exceeds 5,000 square feet.
2. A Group M fire area is located more than three stories above grade plane.
3. The combined area of all Group M fire areas on all floors, including any mezzanines, exceeds 10,000 square feet.
4. A Group M occupancy used for the display and sale of upholstered furniture or mattresses exceeds 5,000 square feet (464 m<sup>2</sup>).
5. The structure exceeds 10,000 square feet, contains more than one fire area containing a Group M occupancy, and is separated into two or more buildings by fire walls of less than 4-hour fire-resistance rating without openings.

Section 903.2.8 is amended to read:

**903.2.8 Group R.** An automatic sprinkler system installed in accordance with Section 903.3 shall be provided throughout all Group R occupancies, including manufactured and mobile homes, including those located in mobile home parks.

Section 903.2.8.1.1 is added, to read:

**903.2.8.1.1 Group R-3 Substantial Addition or Expansion.** An automatic sprinkler system shall be provided throughout all existing Group R-3 dwellings where a substantial addition or expansion occurs and the new total fire area of the structure exceeds 3,600 square feet.

**Exception:** If a sprinkler system is required by the local building department regardless of the size of the addition or expansion, a sprinkler system shall be installed in accordance with the appropriate standard.

Section 903.2.9 is amended to read:

**903.2.9 Group S-1.** An automatic sprinkler system shall be provided throughout all buildings containing a Group S-1 occupancy where one of the following conditions exists:

1. A Group S-1 fire area exceeds 5,000 square feet.
2. A Group S-1 fire area is located more than three stories above grade plane.
3. The combined area of all Group S-1 fire areas on all floors, including any mezzanines, exceeds 10,000 square feet.
4. A Group S-1 occupancy used for the storage of upholstered furniture or mattresses exceeding 2,500 square feet (230 m<sup>2</sup>).

Section 903.2.9.1 is amended to read:

**903.2.9.1 Repair garages.** An automatic sprinkler system shall be provided throughout all buildings used as repair garages in accordance with Section 406.8 of the California Building Code, as shown:

1. Buildings having two or more stories above grade plane, including basements, with a fire area containing a repair garage exceeding 5,000 square feet.
2. Buildings not more than one story above grade plane, with a fire area containing a repair garage exceeding 5,000 square feet.
3. Buildings with repair garages servicing vehicles parked in basements.
4. A Group S-1 fire area used for the repair of commercial motor vehicles where the fire area exceeds 5,000 square feet (464 m<sup>2</sup>).

Section 903.2.10 is amended in its entirety, to read:

**903.2.10 Group S-2.**

**903.2.10.1 Group S-2 enclosed parking garages.** An automatic sprinkler system shall be provided throughout buildings classified as enclosed parking garages in accordance with Section 406.6 of the California Building Code where either of the following conditions exists:

1. Where the fire area of the enclosed parking garage exceeds 5,000 square feet.
2. Where the enclosed parking garage is located beneath other occupancy groups.

**903.2.10.2 Group S-2 Low Hazard Storage.** An automatic sprinkler system shall be provided throughout all buildings containing a Group S-2 occupancy exceeding 5,000 square feet.

Section 903.3.1.1.3 is added, to read:

**903.3.1.1.3 Undeclared Use.** In buildings of undeclared use with floor to structure height greater than 14 feet (4256 mm), the fire sprinkler system shall be designed to conform to Extra Hazard Group I design density. In buildings of undeclared use with floor to structure height less than 14 feet (4256 mm), the fire sprinkler system shall be designed to conform to Ordinary Group II design density. Where a subsequent occupancy requires a system with greater capability, it shall be the responsibility of the owner and/or the occupant to upgrade the system.

Section 903.3.1.3 is amended to read:

**903.3.1.3 Sprinkler Systems for One and Two family dwellings.** Automatic sprinkler systems for one and two- family dwellings shall be permitted to be installed in accordance with sections 903.3.1.3.1 through 903.3.1.3.3.

Sections 903.3.1.3.1, 903.3.1.3.2, and 903.3.1.3.3 are added, to read

**903.3.1.3.1 NFPA 13D Sprinkler Systems.** Automatic sprinkler systems installed in one and two family dwellings, Group R-3 buildings, and townhouses shall be permitted to be installed throughout in accordance with NFPA 13D as amended in Chapter 80.

**903.3.1.3.2 California Residential Code Section R313.** Automatic sprinkler systems shall be permitted to be installed in accordance with California Residential Code section R313.

**903.3.1.3.3 Pipe limitations.** Where CPVC pipe is installed above the insulation or is otherwise located in an unconditioned space, such as in an attic space, or a garage without conditioned living space above,

CPVC pipe shall be adequately insulated to a minimum R-19 value, or equivalent, or pipe shall be limited to Type K or L copper, or ferrous piping.

Section 903.3.5.3 is added, to read:

**903.3.5.3 Non-permissible water supply storage.** Swimming pools and ponds shall not be considered water storage for the purposes of Section 903.3.5.

Section 903.3.9 is amended to read:

**903.3.9. Floor control valves.** Individual floor control valves and waterflow detection assemblies shall be provided for each floor in multi-floor buildings at an approved location.

**Exception:** Group R-3 and R-3.1 Occupancies.

Section 903.4.2 is amended to read:

**903.4.2 Alarms.** One approved audible and visual device shall be connected to every automatic sprinkler system at an approved location. Such sprinkler water-flow alarm devices shall be activated by water flow equivalent to the flow of a single sprinkler of the smallest orifice size installed in the system. Audible and visual alarm devices shall be provided on the exterior of the building in an approved location. Where a fire alarm system is installed, actuation of the automatic sprinkler system shall actuate the building fire alarm system.

Sections 903.6.1 and 903.6.2 are added, to read:

**903.6.1 Substantial Addition or Expansion.** An automatic sprinkler system shall be provided throughout all existing buildings where a substantial addition or expansion occurs and the total fire area of the structure exceeds 5,000 square feet. Group R-3 substantial additions or expansions shall comply with Section 903.2.8.2.1

**903.6.2 Change of occupancy classification.** Any existing building that undergoes a change of occupancy classification into a higher hazard category shall comply with the requirements of Section 903.2. Relative hazard categories of occupancy groups shall be established based upon the Heights and Areas Hazard Categories of Table 1012.4 of the current edition of the International Existing Building Code, as published by the International Code Council. The requirements of Section 903.2 shall not be required when a change of occupancy classification is made to an equal or lesser hazard category. Group L occupancies shall be considered a relative hazard of 1 (highest hazard). Group R-3 occupancies shall be considered a relative hazard of 4 (lowest hazard).

Section 907.4.4 is added, to read:

**907.4.4 Monitoring of other fire systems.** In buildings equipped with a fire alarm system or sprinkler alarm and supervisory service (SASS) system, where other fire suppression or extinguishing systems are installed in the building (including but not limited to commercial kitchen suppression systems, pre-action fire suppression systems, dry chemical systems, and clean agent systems), these other suppression systems shall be monitored by the SASS dedicated function fire alarm system and transmitted as a specific signal to the Central Station. The system shall be monitored in compliance with Section 907.6.5.

Section 907.5.2.3.1 is amended to read:

ORDINANCE NO. 2016-23

**907.5.2.3.1 Public and common areas.** Visible alarm notification appliances shall be provided in public use areas and common use areas, including but not limited to:

1. Sanitary facilities including restrooms, bathrooms, shower rooms, and locker rooms.
2. Corridors, hallways, and aisles with shelving and/or fixtures obstructing the required light intensity for that area.
3. Music practice rooms.
4. Band rooms.
5. Gymnasiums.
6. Multipurpose rooms.
7. Occupational shops.
8. Occupied rooms where ambient noise impairs hearing of the fire alarm.
9. Lobbies.
10. Meeting/Conference rooms.
11. Classrooms.
12. Medical exam rooms.
13. Open office areas.
14. Sales floor areas.
15. Break or lunch rooms
16. Copy or work rooms.
17. Computer server rooms exceeding 200 sq. ft.
18. File or Storage rooms exceeding 200 sq. ft.

Section 907.6.6 is amended to read:

**907.6.6 Monitoring of fire alarm systems.** A fire alarm system required by this chapter, or by the California Building Code, shall be monitored by a UL-listed Central Station service in accordance with NFPA 72 and this code.

**Exception:** Monitoring by a UL-listed central station is not required for:

1. Single and multiple station smoke alarms required by Section 907.2.11.
2. Group I-3 occupancies shall be monitored in accordance with Section 907.2.6.3.4.
3. Residential Day Care Facilities (occupancy load of 14 or less).
4. One and two family dwellings.
5. Residential Care Facilities licensed by the state with an occupant load of 6 or less.
6. Occupancies with a local fire alarm system that will give an audible and visible signal at a constantly attended location, as approved by the Fire Code Official.

Section 907.8.6 is added, to read:

**907.8.6 Certification.** New fire alarm systems shall be UL-Certified. A Certificate of Completion and other documentation as listed in NFPA 72 shall be provided for all new fire alarm system installations. It is the responsibility of the building owner or owner's representative to obtain and maintain a current and valid Certificate.

Section 907.8.6.1 is added, to read:

**907.8.6.1 Posting of Certificate.** The UL Certificate shall be posted in a durable transparent cover within 3 feet of the fire alarm control panel within 45 days of the final acceptance test/inspection.

## Chapter 10. Means of Egress.

Section 1028.5.1 is added, to read:

**1028.5.1 Exit discharge surface.** Exterior exit pathway surfaces shall be suitable for pedestrian use in inclement weather, and shall terminate at a public way as defined in the California Building Code.

## Chapter 33. Fire Safety During Construction and Demolition.

Section 3301.3 is added, to read:

**3301.3 Permits.** Permits shall be obtained for asbestos removal operations, temporary fire department access roads for construction, and temporary water supplies as set forth in sections 105.6 and 105.7.

Section 3318 is added, to read:

### Section 3318 Asbestos removal.

**3318.1 General.** Operations involving removal of asbestos or asbestos-containing materials from buildings shall be in accordance with Section 3318.

**Exception:** Section 3318 does not apply to the removal of asbestos from:

1. Pumps, valves, gaskets and similar equipment.
2. Pipes, ducts, girders or beams that have a length less than 21 linear feet (6400 mm).
3. Wall or ceiling panels that have an area of less than 10 square feet (0.93 m<sup>2</sup>) or a dimension of less than 10 linear feet (3048 mm).
4. Floor tiles when their removal can be completed in less than four hours.
5. Group R-3 occupancies.

**3318.2 Notification.** The fire code official shall be notified 24 hours prior to the commencement and closure of asbestos-removal operations. The permit applicant shall notify the building official when asbestos abatement involves the removal of materials that were used as a feature of the building's fire resistance.

**3318.3 Plastic Film.** Plastic film that is installed on building elements shall be flame resistant as required for combustible decorative material, in accordance with Section 807.

**3318.4 Signs.** Approved signs shall be posted at the entrance, exit and exit-access door, decontamination areas, and waste disposal areas for asbestos-removal operations. The signs shall state that asbestos is being removed from the area, that asbestos is a suspected carcinogen, and that proper respiratory protection is required. Signs shall have a reflective surface. Lettering shall be a minimum of 2 inches (51 mm) high.

## Chapter 50. Hazardous Materials – General Provisions.

Section 5001.5.3 is added, to read:

**5001.5.3 Emergency response support information.** Floor plans, material safety data sheets, Hazardous Materials Management Plans (HMMP), Hazardous Material Inventory Statements (HMIS), and other information must be stored at a readily accessible location, as determined by the fire code official. This



location may be in cabinets located outside of facilities or buildings. Information may be required to be maintained in a specific electronic media format to facilitate computer aided dispatching.

Section 5003.9.1.2 is added, to read:

**5003.9.1.2 Documentation.** Evidence of compliance with provisions of this chapter as well as with state and federal hazardous material regulations shall be maintained on site and available for inspection by fire department personnel.

## **Chapter 56. Explosives and Fireworks.**

Section 5601.1.3 is amended to read:

**5601.1.3 Fireworks.** The possession, manufacture, storage, sale, handling, and use of fireworks are prohibited within the jurisdiction of the District.

**Exceptions:**

1. The use of fireworks for fireworks displays, pyrotechnics before a proximate audience, pyrotechnic special effects in motion pictures, television, theatrical, or group entertainment productions as allowed by Title 19, Division 1, Chapter 6 Fireworks reprinted in Section 5608 and the Health and Safety Code Division 11.
2. Snap Caps and Party Poppers classified by the State Fire Marshal as pyrotechnic devices.

Section 5601.2.2 is amended to read:

**5601.9 Sale and retail display.** No person shall construct a retail display or offer for sale any explosives, explosive materials, or fireworks within the jurisdiction.

**Exception:** Snap Caps and Party Poppers classified by the State Fire Marshal as pyrotechnic devices.

Section 5601.2.4 is amended as follows:

**5601.2.4 Financial responsibility.** Before a permit is issued pursuant to Section 5601.2, the applicant shall file with the jurisdiction a corporate surety bond in the principal sum of \$2,000,000 or a public liability insurance policy for the same amount, for the purpose of the payment of all damages to persons or property which arise from, or are caused by, the conduct of any act authorized by the permit upon which any judicial judgment results. The fire code official is authorized to specify a greater or lesser amount when, in his or her opinion, conditions at the location of use indicate a greater or lesser amount is required. Government entities shall be exempt from this bond requirement.

**Exception:** Fireworks in accordance with California Code of Regulations, Title 19, Division 1, Chapter 6. See Section 5608.

Section 5601.9 is added, to read:

**5601.9 Prohibited and Limited Acts.** The storage of explosive materials is prohibited in all zoning districts except districts zoned for industrial or agricultural uses. In districts where the storage of explosive materials is permitted, the quantities of explosives and distances shall be in accordance with California Fire Code Section 5601.8.

## Chapter 57. Flammable and Combustible Liquids.

Section 5704.2.9.6.1 is amended to read:

**5704.2.9.6.1 Locations where above-ground tanks are prohibited.** The storage of Class I and II liquids in above-ground tanks outside of buildings is prohibited in all zoning districts except districts zoned for commercial, industrial, or agricultural uses.

**Exception:** Protected above-ground tanks for the purpose of emergency power generator installations in areas zoned commercial, industrial, agricultural, central business district, rural or rural residential, and for facilities on an individual basis consistent with the intent of this provision. Tank size shall not exceed 500 gallons (1892.706L) for Class I or II liquids, or 1,000 gallons (3785.412L) for Class III liquids.

Section 5706.2.4.4 is amended to read:

**5706.2.4.4 Locations where above-ground tanks are prohibited.** Storage of Class I and II liquids in above-ground tanks is prohibited in all zoning districts except district zoned for commercial, industrial, or agricultural use.

## Chapter 58. Flammable Gases and Flammable Cryogenic Fluids.

Section 5806.2 is amended to read:

**5806.2 Limitation.** The storage of flammable cryogenic fluids in stationary containers outside of buildings is prohibited in any area which is zoned for other than industrial use.

**Exception:** Liquid hydrogen fuel systems in compliance with Section 5806.3 or 5806.4.

## Chapter 61. Liquefied Petroleum Gases.

Section 6103.2.1.7 is amended to read:

**6103.2.1.7 Use for food preparation.** Individual portable L-P containers used, stored, or handled inside a building classified as a Group A, Group B, or Group M occupancy for the purposes of cooking, food display, or a similar use, shall be limited in size to one quart capacity and shall be of an approved type. The number of portable containers permitted will be at the discretion of the fire code official. LP-gas appliances used for food preparation shall be listed for such use in accordance with the California Mechanical Code and NFPA 58.

Section 6104.2 is amended to read:

**6104.2 Maximum capacity within established limits.** The storage of liquefied petroleum gas is prohibited in any central business district and in all zoning districts except districts zoned for commercial, industrial, rural, or agricultural uses. The aggregate capacity of any one installation used for the storage of liquefied petroleum gas shall not exceed a water capacity of 2,000 gallons (7570 L).

## Chapter 80. Referenced Standards.

Chapter 80 is amended by adding the following referenced standards:

ORDINANCE NO. 2016-23

NFPA 3 (2015): Recommended Practice for Commissioning of Fire Protection and Life Safety Systems

NFPA 4 (2015): Standard for Integrated Fire Protection and Life Safety System Testing

NFPA 850 (2015): Recommended Practice for Fire Protection for Electric Generating Plants and High Voltage Direct Current Converter Stations

Chapter 80 is further amended by amending the NFPA 13D (2016) (Standard for the Installation of Sprinkler Systems in One- and Two-Family Dwellings and Manufactured Homes) standard as follows:

Section 7.7.1 is added, to read:

**7.7.1** Where CPVC pipe is installed above the normal insulation in an unconditioned space, such as in an attic space, or a garage without conditioned living space above, CPVC pipe shall be adequately insulated to a minimum R-19 value, or equivalent, or pipe shall be limited to Type K or L copper, or ferrous piping.

Section 8.3.5.1.2 is amended to read:

**8.3.5.1.2** Where fuel-fired equipment is below or on the same level as occupied areas of the dwelling unit, at least one quick-response intermediate temperature sprinkler shall be installed above the equipment or at the wall separating the space with the fuel-fired equipment from the occupied space. In unconditioned spaces, CPVC pipe shall be adequately insulated to a minimum R-19 value, or equivalent, or pipe shall be limited to Type K or L copper, or ferrous piping.

## **Appendix B. Fire-Flow Requirements for Buildings.**

Section B105.2 is amended by amending the exception to read:

### **Exceptions:**

1. Group B, S-2, and U occupancies having a floor area not exceeding 1,000 square feet, primarily constructed of noncombustible exterior walls with wood or steel roof framing, having a Class A roof assembly, with uses limited to the following or similar uses:
  - 1.1. California State Parks buildings of an accessory nature (restrooms).
  - 1.2. Safety roadside rest areas, (SRRA), public restrooms.
  - 1.3. Truck inspection facilities, (TIF), CHP office space and vehicle inspection bays.
  - 1.4. Sand/salt storage buildings, storage of sand and salt.
2. A reduction in required fire-flow of 50 percent, as approved by the fire code official, when the building is provided with an approved automatic sprinkler system and installed in accordance with Section 903.3.1.1. The resulting fire-flow shall be not less than 1,500 gallons per minute (5678L/min) for the prescribed duration as specified in Table B105.1.

## **Appendix C. Fire Hydrant Locations and Distribution.**

Table C102.1 is amended as follows:

The title of Table C102.1 is amended to read:

ORDINANCE NO. 2016-23

TABLE C102.1<sup>i</sup>

The heading of the fourth column of Table C102.1 is amended to read:

MAXIMUM DISTANCE FROM ANY POINT ON STREET OR ROAD FRONTAGE TO A  
HYDRANT<sup>d,f,g,h</sup>

Footnotes “h” and “i” are added to Table C102.1, to read:

- h. A fire hydrant shall be provided within 250 feet of a fire trail access point off a public or private street.
- i. For infill projects within existing single-family residential developments, Section 507.5.1 applies.

**Appendix D. Fire Apparatus Access Roads.**

Section D102.1 is amended to read:

**D102.1 Access and loading.** Facilities, buildings or portions of buildings hereafter constructed shall be accessible to fire department apparatus by way of an approved fire apparatus access road with an asphalt, concrete, or other approved all-weather driving surface capable of supporting the imposed load of fire apparatus weighing at least 74,000 pounds (33 566 kg) in accordance with CalTrans Design Standard HS-20-44.

**Exception:** Driveways serving one or two single-family dwellings may be constructed of an alternate surface material, providing the imposed weight load design minimums are met and the grade does not exceed 10 percent.

Section D103.1 is deleted.

Section D103.2 is amended to read:

**D103.2 Grade.** Fire department access roadways having a grade of between 16 percent and 20 percent shall be designed to have a finished surface of grooved concrete sufficient to hold a 44,000 pound (19 958 kg) traction load. The grooves in the concrete surface shall be ½ inch (13 mm) wide by ½ inch (13 mm) deep and 1 ½ inch (38 mm) on center and set at a 30 to 45 degree angle across the width of the roadway surface. No grade shall exceed 20 percent, nor shall the cross slope exceed 8%, unless authorized in writing by the fire code official.

Section D103.2.1 is added, to read:

**D103.2.1 Angles of approach and departure.** The angles of approach and departure for any means of access shall not exceed 10 percent at 10 feet of the grade break.

Section D103.3 is amended to read:

**D103.3 Turning radius.** Based on a minimum unobstructed width of 20 feet, a fire apparatus access roadway shall be capable of providing a minimum standard turning radius of 25 feet (7620 mm) inside and 45 feet (13 716 mm) outside.

ORDINANCE CONTINUES ON NEXT PAGE

Table D103.4 is amended to read:

**Table D103.4**  
**REQUIREMENTS FOR DEAD-END FIRE**  
**APPARATUS ACCESS ROADS**

LENGTH (feet)	MINIMUM WIDTH (feet)	TURNAROUNDS REQUIRED
0 – 150	20 <sup>a</sup>	None required
151 – 750	20 <sup>a</sup>	100-foot Hammerhead, 50-foot “Y”, 75-foot Shunt or 90-foot-diameter cul-de-sac in accordance with figure D103.1
Over 750	Special approval required <sup>b</sup>	

- a. A driveway with a minimum width of 16 feet is acceptable for access to no more than two single-family dwellings.
- b. Any fire apparatus access roadway or driveway that is approved to be less than 20 feet wide and to exceed 750 feet in length shall have outsets or turnouts every 300 feet along the length of the road or driveway, or at locations approved by the fire code official. Each outset or turnout shall be of the following dimensions: an 8 foot wide turnout that extends at least 40 feet in length.

Figure D103.1 is amended to read:

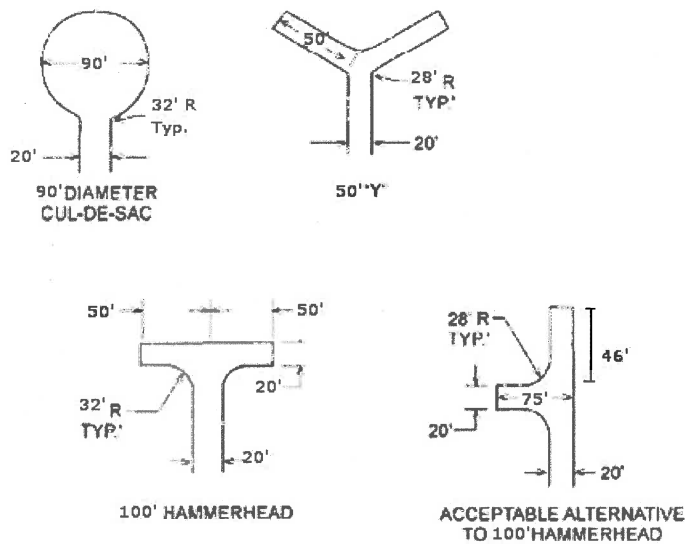

**Figure D103.1**  
**Dead-end Fire Apparatus Access Road Turnaround**

Section D103.5 is amended as follows:

Criteria 1 of Section D103.5 is amended to read:

1. The minimum clear width shall be 20 feet (6096mm).

**Exception:** For access to one or two single-family dwellings, 16 feet clear width is acceptable.

Criteria 9 is added to Section D103.5, to read:

9. All gates shall be installed and located a minimum of 30 feet off the street.

Section D103.6.1 is amended to read:

**D103.6.1 Roads less than 28 feet in width.** Fire apparatus access roads less than 28 feet wide shall be posted on both sides as a fire lane.

Section D103.6.2 is amended to read:

**D103.6.2 Roads 28 feet in width or greater, but less than 36 feet in width.** Fire apparatus access roads 28 feet wide or greater, but less than 36 feet wide, shall be posted on one side of the road as a fire lane.

Section D106.1 is amended by deleting the exception and to read:

**D106.1 Projects having more than 100 dwelling units.** Multiple-family residential projects having more than 100 dwelling units shall be provided with two separate and approved fire apparatus access roads and shall meet the requirements of Section D104.3.

Section D106.2 is deleted in its entirety.

### SECTION 3. REPEAL OF FIRE CODE.

Ordinance No. 2013-22, adopting the 2013 California Fire Code with amendments, is hereby repealed.

### SECTION 4. REFERENCES TO PRIOR CODE.

Unless superseded and expressly repealed, references in City forms, documents, and regulations to the chapters and sections of the Fire Code of Contra Costa County, the Crockett-Carquinez Fire Protection District, and the Contra Costa County Fire Protection District, 2013, shall be construed to apply to the corresponding provisions contained within the Fire Code of Contra Costa County, the Crockett-Carquinez Fire Protection District, and the Contra Costa County Fire Protection District, 2016. Ordinance 2013-22 and all other ordinances or parts of ordinances in conflict herewith are hereby superseded and expressly repealed.

### SECTION 5. VALIDITY.

The Contra Costa County Board of Supervisors declares that if any section, paragraph, sentence, or word of this ordinance or of the 2016 California Fire Code as adopted and amended herein is declared for any reason to be invalid, it is the intent of the Contra Costa County Board of Supervisors that it would have passed all other portions or provisions of this ordinance independent of the elimination here from any portion or provision as may be declared invalid.

SECTION 6. MORE RESTRICTIVE REQUIREMENTS.

If requirements more restrictive than those in this fire code are adopted by the city of Antioch, Clayton, Concord, Lafayette, Martinez, Pittsburg, Pleasant Hill, San Pablo, or Walnut Creek, or the County of Contra Costa, those requirements will apply only within the jurisdiction adopting those requirements.

SECTION 7. EFFECTIVE DATE.

This ordinance becomes effective on January 1, 2017 or 30 days after passage, whichever is later. Within 15 days of passage, this ordinance shall be published once in the Contra Costa Times, a newspaper published in this County. This ordinance shall be published in a manner satisfying the requirements of Government Code Section 25124, with the names of supervisors voting for and against it.

Passed on November 1 2016, by the following vote:

- AYES: Gioia, Andersen, Piepho, Mitchoff, Glover
- NOES: None
- ABSENT: None
- ABSTAIN: None

ATTEST: David Twa,  
Clerk of the Board of Supervisors  
and County Administrator

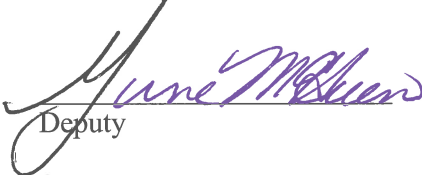

Board Chair Candace Andersen

By:   
Deputy

[SEAL]

KCK:  
H:\FPD\2016\Fire Code Ord\Ordinance No. 2016-23 Fire Code Adoption Ord - final.docx



CONTRA COSTA COUNTY, CONTRA COSTA COUNTY FIRE PROTECTION DISTRICT,  
AND CROCKETT-CARQUINEZ FIRE PROTECTION DISTRICT  
FINDINGS IN SUPPORT OF AMENDMENTS TO THE 2016 CALIFORNIA BUILDING  
STANDARDS CODE, TITLE 24, PART 9, CALIFORNIA FIRE CODE

The California Building Standards Commission has adopted and published the 2016 California Fire Code. The purpose of the code is to regulate and govern the safeguarding of life and property from fire and explosion hazards arising from the storage, handling, and use of hazardous substances, materials, and devices, and from conditions hazardous to life or property in the occupancy of buildings and premises.

Health and Safety Code section 17958.5 and 18941.5 authorize a local jurisdiction to modify or change the statewide codes and establish more restrictive building standards if the jurisdiction finds that the modifications and changes are reasonably necessary because of local climatic, geological, or topographical conditions.

Ordinance No. 2016-23 adopts the 2016 California Fire Code and amends it to address local conditions. Pursuant to Sections 17958.5 and 17958.7 of the Health and Safety Code, the Contra Costa County Board of Supervisors, in its capacity as the Board of Supervisors and the Board of Directors of the Contra Costa County Fire Protection District and the Crockett-Carquinez Fire Protection District, finds that the more restrictive standards contained in Ordinance No. 2016-23 are reasonably necessary because of certain local climatic, geological, and topographic conditions that are described below.

Local Conditions

A. Climatic

1. Precipitation and Relative Humidity

(a) Conditions

Precipitation ranges from 15 to 24 inches per year with an average of approximately 20 inches per year. Ninety-six (96) percent falls during the months of October through April and four (4) percent from May through September. This is a dry period of at least five (5) months each year. Additionally, the area is subject to occasional drought. Relative humidity remains in the middle range most of the time. It ranges from forty-five (45) to sixty-five (65) percent during spring, summer, fall, and from sixty (60) to ninety (90) percent in the winter. It occasionally falls as low as fifteen (15) percent.

(b) Impact

Locally experienced dry periods cause extreme dryness of untreated wood shakes and shingles on buildings and non-irrigated grass, brush, and weeds, which are often near buildings with wood roofs and sidings. Such dryness causes these materials to ignite very readily and burn rapidly and intensely.

Because of dryness, a rapidly burning grass fire or exterior building fire can quickly transfer to other buildings by means of radiation or flying brands, sparks, and embers. A small fire can rapidly grow to a magnitude beyond the control capabilities of the Fire District resulting in an excessive fire loss.

2. Temperature

(a) Conditions

Temperatures have been recorded as high as 114° F. Average summer highs are in the 90° range, with average maximums of 105° F.

(b) Impact

High temperatures cause rapid fatigue and heat exhaustion of firefighters, thereby reducing their effectiveness and ability to control large building and wildland fires.

Another impact from high temperatures is that combustible building material and non-irrigated weeds, grass, and brush are preheated, thus causing these materials to ignite more readily and burn more rapidly and intensely. Additionally, the resultant higher temperature of the atmosphere surrounding the materials reduces the effectiveness of the water being applied to the burning materials. This requires that more water be applied, which in turn requires more Fire District resources in order to control a fire on a hot day. High temperatures directly contribute to the rapid growth of fires to an intensity and magnitude beyond the control capabilities of the Fire District.

3. Winds

(a) Conditions

Prevailing winds in the area are from the south or southwest in the mornings and from the north or northwest in the afternoons. However, winds are experienced from virtually every direction at one time or another. Velocities are generally in the fourteen (14) mph to twenty-three (23) mph ranges, gusting to twenty-five (25) to thirty-five (35) mph. Forty (40) mph winds are experienced occasionally and winds up to fifty-five (55) mph have been registered locally. During the winter half of the year, strong, dry, gusty winds from the north move through the area for several days creating extremely dry conditions.

(b) Impact

Winds such as those experienced locally can and do cause fires, both interior and exterior, to burn and spread rapidly. Fires involving non-irrigated weeds, grass, and brush can grow to a magnitude and be fanned to intensity beyond the control capabilities of the Fire District very quickly even by relatively moderate winds. During wood shake and shingle roof fires, or exposure fires, winds can carry sparks and burning brands to other structures, thus spreading the fire and causing conflagrations. When such

fires are not controlled, they can extend to nearby buildings, particularly those with untreated wood shakes or shingles. In building fires, winds can literally force fires back into the building and can create a blow torch effect, in addition to preventing “natural” ventilation and cross-ventilation efforts.

Winds of the type experienced locally also reduce the effectiveness of exterior water streams used by the Fire District on fires involving large interior areas of buildings, fires which have vented through windows and roofs due to inadequate built-in fire protection and fires involving wood shake and shingle building exteriors. Local winds will continue to be a definite factor towards causing major fire losses to buildings not provided with fire resistive roof and siding materials and buildings with inadequately separated interior areas or lacking automatic fire protection systems. National statistics frequently cite wind conditions, such as those experienced locally, as a major factor where conflagrations have occurred.

## B. Geological and Topographic

### 1. Seismicity

#### (a) Conditions

Contra Costa County is located in Seismic Risk Zone 4, which is the worst earthquake area in the United States. Buildings and other structures in Zone 4 can experience major seismic damage. Contra Costa County is in close proximity to the San Andreas Fault and contains all or portions of the Hayward, Calaveras, Concord, Antioch, Mt. Diablo, and other lesser faults. A 4.1 earthquake with its epicenter in Concord occurred in 1958, and a 5.4 earthquake with its epicenter also in Concord occurred in 1955. The Concord and Antioch faults have a potential for a Richter 6 earthquake and the Hayward and Calaveras faults have the potential for a Richter 7 earthquake. Minor tremblers from seismic activity are not uncommon in the area.

The fire environment of a community is primarily a combination of two factors: the area’s physical geologic characteristics and a historic pattern of urban-suburban development. These two factors, alone and combined, create a mixture of environments which ultimately determines the area’s fire protection needs. The Fire District has 3 distinct areas. They are: the West, which includes the City of San Pablo and the communities of North Richmond, El Sobrante, and East Richmond Heights; the Central, which includes the Cities of Lafayette, Martinez, Pleasant Hill, Concord, Walnut Creek, Clayton, and the communities of Clyde, Pacheco, Alhambra Valley, and Alamo; and the East, which includes the Cities of Antioch and Pittsburg and the community of Bay Point.

Because of the size of the Contra Costa County Fire Protection District (304 Square miles), the characteristics of the fire environment changes from one

location to the next. Therefore the District has not one, but a number of fire environments, each of which has its individual fire protection needs from two major oil refineries, to heavy industrial facilities, freeways, rail lines, waterways, port facilities, wildland areas, urban and suburban town settings, and major downtown areas.

Interstates 80 and 680, State Highways 4, 24, and 242, Bay Area Rapid Transit District (BART), and major thoroughfares travel throughout the District. There are 2 major rail lines which run through the District. An overpass or underpass crossing collapse would alter the response route and time for responding emergency equipment. This is due to the limited crossings of the major highways and rail lines.

Earthquakes of the magnitude experienced locally can cause major damage to electrical transmission facilities, which, in turn, cause power failures while at the same time starting fires throughout the Fire District. The occurrence of multiple fires will quickly deplete existing fire district resources; thereby reducing and/or delaying their response to any given fire. Additionally, without electrical power, elevators, smoke management systems, lighting systems, alarm systems, and other electrical equipment urgently needed for building evacuation and fire control in large buildings without emergency generator systems would be inoperative, thereby resulting in loss of life and/or major fire losses in such buildings.

(b) Impact

A major earthquake could severely restrict the response of the Fire District and its capability to control fires involving buildings of wood frame construction, with ordinary wood shake and shingle exteriors, or with large interior areas not provided with automatic smoke and fire control systems.

2. Soils

(a) Conditions

The area is replete with various soils, which are unstable, clay loam and alluvial fans being predominant. These soil conditions are moderately to severely prone to swelling and shrinking, are plastic, and tend to liquefy.

Throughout the Fire District, the topography and development growth has created a network of older, narrow roads. These roads vary from gravel to asphalt surface and vary in percent of slope, many exceeding twenty (20) percent. Several of these roads extend up through the winding passageways in the hills providing access to remote, affluent housing subdivisions. Many of these roads are private with no established maintenance program. During inclement weather, these roads are subject to rock and mudslides, as well as down trees, obstructing all vehicle traffic. It is anticipated that during an earthquake, several of these roads would be practically impassable.

3. Topographic

(a) Conditions

(i) Vegetation

The service area of the Contra Costa County Fire Protection District has a varied topography and vegetative cover. A conglomeration of flat lands, hills, and ridges make up the terrain. Development has occurred on the flat lands in the District and in the past 15 years development has spread into the hills, valleys, and ridge lands of the District.

Highly combustible dry grass, weeds, and brush are common in the hilly and open space areas adjacent to built-up locations six (6) to eight (8) months of each year. Many of these areas frequently experience wildland fires, which threaten nearby buildings, particularly those with wood roofs, or sidings. This condition can be found throughout the Fire District, especially in those fully developed areas and those areas marked for future development.

(ii) Surface Features

The arrangement and location of natural and manmade surface features, including hills, creeks, canals, freeways, housing tracts, commercial development, fire stations, streets, and roads, combine to limit efficient response routes for Fire District resources into and through many areas.

(iii) Buildings, Landscaping and Terrain

Many of the “newer” large buildings and building complexes have access and landscaping features or designs which preclude, or greatly limit, efficient approach or operational access to them by Fire District vehicles. In addition, the presence of security gates, roads of inadequate width and grades which are too steep for Fire District vehicles create an adverse impact on fire suppression efforts.

When Fire District vehicles cannot gain access to buildings involved with fire, the potential for complete loss is realized. Difficulty reaching a fire site often requires additional fire personnel and resources to successfully and safely mitigate the event. Access problems often result in severely delaying, misdirecting, or making fire and smoke control efforts unsuccessful.

(b) Impact

The above local geological and topographical conditions increase the magnitude, exposure, accessibility problems, and fire hazards presented to the Contra Costa County Fire Protection District. Fire following an earthquake has the potential of causing greater loss of life and damage than

the earthquake itself. Hazardous materials, particularly toxic gases, could pose the greatest threat to the largest number, should a significant seismic event occur. Public Safety resources would have to be prioritized to mitigate the greatest threat, and may likely be unavailable for smaller single dwelling or structure fires.

Other variables may intensify the situation:

1. The extent of damage to the water system.
2. The extents of isolation due to bridge and/or freeway overpass collapse.
3. The extent of roadway damage and/or amount of debris blocking the roadways.
4. Climatic conditions (hot, dry weather with high winds).
5. Time of day will influence the amount of traffic on roadways and could intensify the risk to life during normal business hours.
6. The availability of timely mutual aid or military assistance.
7. The large portion of dwellings with wood shake or shingles coverings could result in conflagrations.

#### Necessity for More Restrictive Standards

Because of the conditions described above, the Contra Costa County Board of Supervisors, in its capacity as the Board of Supervisors and the Board of Directors of the Contra Costa County Fire Protection District and the Crockett-Carquinez Fire Protection District, finds that there are building and fire hazards unique to Contra Costa County that requires the increased fire protection requirements set forth in Ordinance No. 2016-23.

The ordinance amends Chapter 1 (Scope and Administration) of the statewide Fire Code by requiring a permit for certain activities and operations that pose fire hazards. The ordinance amends the statewide Fire Code by incorporating into Chapter 3 (General Precautions Against Fire) the fire districts' existing weed abatement program that authorizes the fire districts to declare certain weeds that pose a fire hazard as a public nuisance and to abate those weeds. The ordinance amends Chapter 4 of the statewide Fire Code (Emergency Planning and Preparedness) to require standby EMS personnel for large events as well as standby fire personnel to account for the fact that the fire district is both the local fire and EMS provider. The ordinance amends the statewide Fire Code by reducing the square footage thresholds found in Chapter 9 (Fire Protection Systems) for installation of automatic fire sprinkler systems in most commercial buildings and in private and charter schools. The ordinance amends Chapter 5 (Fire Service Features) and Appendix D (Fire Apparatus Access Roads) of the statewide Fire Code to establish requirements for fire apparatus access roads.



Contra  
Costa  
County

To: Board of Supervisors  
From: John Kopchik, Director, Conservation & Development Department  
Date: November 1, 2016

Subject: Permit Review of Keller Canyon Landfill's Land Use Permit

---

**RECOMMENDATION(S):**

1. OPEN the public hearing, RECEIVE testimony, and CLOSE the public hearing.
2. ACCEPT the permit review report pertaining to the Keller Canyon Landfill land use permit conditions of approval, which concludes that there is no need to add or modify the existing permit conditions (Exhibit B), as recommended by the County Planning Commission (Exhibit A).
3. DIRECT Department of Conservation and Development staff to schedule the third annual permit review for consideration by the County Planning Commission in October 2017, to satisfy the requirement that permit reviews be completed annually for three years, and thereafter reviews are to occur once every three years in accordance with Condition 11.1 of the existing Keller Canyon Landfill land use permit.

**FISCAL IMPACT:**

The land use permit (LUP) review itself has no impact to the County General Fund. Keller Canyon Landfill Company, the landfill operator, is responsible for providing reimbursement for the County's staff costs associated with the permit review process.

- 
- APPROVE
  OTHER  
 RECOMMENDATION OF CNTY ADMINISTRATOR
  RECOMMENDATION OF BOARD COMMITTEE
- 

Action of Board On: **11/01/2016**  APPROVED AS RECOMMENDED  OTHER

Clerks Notes:

**VOTE OF SUPERVISORS**

I hereby certify that this is a true and correct copy of an action taken and entered on the minutes of the Board of Supervisors on the date shown.

ATTESTED: November 1, 2016

Contact: David Brockbank,  
925-674-7794

David J. Twa, County Administrator and Clerk of the Board of Supervisors

By: , Deputy

cc:

## BACKGROUND:

This is the second permit review of the Keller Canyon Landfill (KCL) LUP conditions of approval. The staff report to the County Planning Commission (CPC) was prepared in accordance with LUP condition 11.1 and the Permit Review Criteria (Exhibit C), approved by the Board in 1995. Condition 11.1 affords the Board of Supervisors the opportunity to approve new and/or modified conditions of approval to improve public health, safety, and welfare. It also provides for approval of new or modified conditions to address inconsistencies resulting from court decisions or regulatory changes made since the permit was approved or was most recently amended/modified. As a result of the second permit review detailed in the report reviewed by the CPC on October 11, 2016 (Exhibit B), it was concluded that there is no need to recommend approval of any new or modified conditions of approval for the existing KCL LUP. (i.e. no changes recommended to the modified permit conditions approved by the Board last year)

## **KCL PERMIT REVIEW: OCTOBER 2014 - SEPTEMBER 2015**

The first permit review process began in 2014 and was fully concluded in September 2015. In accordance with the approved Permit Review Criteria (Exhibit C), the Board added five new conditions and modified 82 of the existing conditions due to the approvals granted in response to the initial permit review process. The modifications to the LUP conditions better reflect the established landfill operations in the context of present day environmental and regulatory settings. The first permit review process began similarly to this permit review, with staff compiling information called for in Part I of the Permit Review Criteria in order to prepare the permit review staff report presented to the CPC in October 2014. That report provided substantive information about the 22 year operational and regulatory history since the landfill opened in 1992, as well as other information called for in the Criteria. It was accompanied by a Compliance Status Table exhibit that addressed each of the existing conditions of approval.

The Board of Supervisors heard the first LUP review report from the CPC on December 16, 2014. Following a lengthy discussion at this meeting, the Board unanimously approved modifications recommended for three conditions of approval (20.3, 25.4, and 31.5). These three conditions were modified to explicitly allow for certain materials being used as alternative daily cover (ADC) at the landfill. The permit review was continued to March 3, 2015, as an open public hearing because the Board directed staff to provide additional information they wanted to consider before acting on the remaining recommended modifications. Staff was directed to research and report back on several additional, separate but related items pertaining to on-site material recovery, the City of Pittsburg proposal to take over as the Local Enforcement Agency (LEA), potential County fee/surcharge revenue impacts expected to result if the optional direct haul restrictions were approved, and any California Environmental Quality Act (CEQA) implications resulting from approving either version of new and modified conditions of approval.

In response to Board direction, staff prepared a detailed report on the KCL permit review for the March 3, 2015 meeting. That open public hearing was continued to March 31, 2015, and then again to July 21, 2015, at the request of the District V Supervisor. At that meeting, Department of Conservation and Development (DCD) staff recommended that the Board of Supervisors (Board) continue the item once more to September 22, 2015, so that the District V Supervisor could participate in the decision making process. Staff's report to the Board in September 2015 presented detailed explanations on the additional topics mentioned above. At that time the Board was presented with two options for new and modified conditions to consider. The primary difference between the two options were the proposed new conditions, where one version allowed loads of mixed construction and demolition (C&D) material suitable for recovery at local transfer stations to be direct hauled to the landfill contingent upon the implementation of certain on-site waste recovery, and the other option required those loads go through a transfer station first. The Board approved the option that limited the direct haul of materials that would be potentially recovered if first delivered to a transfer station in accordance with previously approved Board policy that had not been formerly integrated into the LUP. However, the Board approval allowed a grace period of 18 months for the four new direct haul conditions to take effect following the September 22, 2015 hearing.

## **PERMIT REVIEW HEARING - COUNTY PLANNING COMMISSION: OCTOBER 2016**

A public hearing was held before the CPC on Tuesday, October 11, 2016, to review the existing conditions of approval for KCL's LUP, as modified in September 2015. Condition 11.1 affords the Board of Supervisors the



opportunity to review the conditions and determine if any new or modified conditions are needed to improve public health, safety, and welfare. The condition also makes clear the County is not precluded from addressing emergency situations, or new requirements imposed by legislation or the courts. Staff concluded that no new or modified conditions needed to be recommended for the existing KCL LUP as a result of this second permit review process which is documented in the attached report presented to the CPC, in accordance with the Board approved Permit Review Criteria.

A substantive amount of time was dedicated to researching and compiling information, as well as working with the landfill operator and other governmental agencies to prepare the report and associated exhibits presented to the CPC (Exhibits B and D). At the October 11, 2016 hearing, the CPC opened the public hearing and took testimony from three speakers: a concerned resident living near the landfill, a permit engineer in the solid waste industry, and a representative of a local Teamsters Union. The speakers supported staff's recommendation to the CPC. All three speakers also spoke favorably of the four new conditions of approval related to the direct haul of C&D material, which were added in the previous permit review approved in 2015. As noted previously, the Board granted an 18 month grace period for the direct haul conditions to go into effect, so they will become effective in late March 2017. Staff expects the landfill operator to begin developing documentation and implementing the tasks necessary to comply with the new conditions by the time they take effect next Spring. The County Planning Commission then closed the public hearing and voted to recommend that the Board of Supervisors accept the Permit Review Report (Exhibit B) and direct DCD staff to schedule the next permit review in one year.

#### CONSEQUENCE OF NEGATIVE ACTION:

If the Board does not accept the report on the second KCL land use permit, the existing conditions of approval would still remain in effect and continue to govern the use of the landfill site.

#### CLERK'S ADDENDUM

Speakers: Don E. Garcia, Teamsters 315; Lisa Della Rocca, resident of Pittsburg (handout attached); Laura Wright, City of Pittsburg; EVan xxxxx; Dana Dean, representing Evan Edgar and Monica White; Greg Osorio, Garrett Evans;

***CLOSED the public hearing; ACCEPTED the permit review report pertaining to the Keller Canyon Landfill land use permit conditions of approval, which concludes that there is no need to add or modify the existing permit conditions; and DIRECTED Department of Conservation and Development staff to schedule the third annual permit review for consideration by the County Planning Commission in October 2017, in accordance with Condition 11.1 of the existing Keller Canyon Landfill land use permit.***

#### AGENDA ATTACHMENTS

Exhibit A: CPC Resolution - October 2016

Exhibit B: Permit Review Staff Report / Existing LUP Conditions of Approval / Maps - October 2016

Exhibit C: Permit Review Criteria - June 1995

Exhibit D: Compliance Status Table - September 2016

#### MINUTES ATTACHMENTS

Correspondence Received

## RESOLUTION NO. 613-2016

**RESOLUTION OF THE COUNTY PLANNING COMMISSION OF THE COUNTY OF CONTRA COSTA, STATE OF CALIFORNIA, PERMIT REVIEW HEARING RECOMMENDING ACCEPTANCE OF REPORT CONCLUDING THERE IS NO NEED TO ADD OR MODIFY ANY EXISTING CONDITIONS OF APPROVAL FOR THE KELLER CANYON LANDFILL LAND USE PERMIT, COUNTY FILE #LP89-2020 AS AMENDED AND MODIFIED, IN THE PITTSBURG/BAY POINT AREA OF SAID COUNTY.**

WHEREAS, in 1990, the Board of Supervisors approved County File #LP89-2020 to allow the construction and operation of Keller Canyon Landfill, which included condition of approval #11.1 that allows for the addition or modification of permit conditions through permit review hearings; and

WHEREAS, in 1995, the Board of Supervisors approved a Board Order that outlined the criteria to add or modify the conditions of approval that would improve public health, safety, and welfare. The approved Criteria also specified that additional modifications to the conditions of approval may be considered to address inconsistencies resulting from court decisions or regulatory changes that occurred since the permit was approved in July 1990 or subsequently amended or modified; and

WHEREAS, on September 22, 2015, the Contra Costa County Board of Supervisors approved new and modified conditions as part of the first permit review, and directed the Department of Conservation and Development ("DCD") staff to prepare the second annual permit review for consideration by the County Planning Commission in October 2016 in accordance with the conditions of approval for County File #LP89-2020 as amended and modified; and

WHEREAS, after notice was lawfully given, a public hearing was scheduled before the County Planning Commission on October 11, 2016, at which time all persons interested therein had the opportunity to appear and be heard; and

WHEREAS, on Tuesday, October 11, 2016, the County Planning Commission opened the public hearing, and after having received, considered, and evaluated the information presented by staff and all the testimony provided by persons interested in this matter, closed the public hearing.

NOW, THEREFORE BE IT RESOLVED, that the County Planning Commission takes the following actions:

- 1) CONSIDER the information presented in the October 11, 2016 staff report and the associated Compliance Status Table (Exhibit D), which provides the background and context necessary to satisfy Part I of the 1995 Permit Review Criteria (Exhibit C) approved by the Board of Supervisors for KCL's Land Use Permit, County File #LP98-2020; and
- 2) RECOMMEND that the Board of Supervisors accept the second permit review report prepared by staff for the Keller Canyon Landfill land use permit (see Exhibit B), pursuant to the 1995 Board approved Permit Review Criteria, and;
- 3) RECOMMEND that the Board of Supervisors direct DCD staff to schedule the next permit review in one year.

These actions were the subject of a motion approved by the County Planning Commission on Tuesday, October 11, 2016, by the following vote:

AYES: Commissioners – Terrell, Wright, Clark, Snyder, and Steele

NOES: Commissioners – None

ABSENT: Commissioners – Swenson

ABSTAIN: Commissioners – None

BE IT FURTHER RESOLVED that the Secretary of the County Planning Commission shall respectively sign and attest the certified copy of this resolution and deliver the same to the Board of Supervisors all in accordance with the Planning Laws of the State of California.

Duane Steele,  
Chair of the County Planning Commission,  
County of Contra Costa, State of California

ATTEST:

  
\_\_\_\_\_  
Aruna Bhat, Secretary  
County Planning Commission  
County of Contra Costa  
State of California



# Department of Conservation and Development

## County Planning Commission

Tuesday, October 11, 2016 – 7:00 .P.M.

### STAFF REPORT

Agenda Item # 2a

<b>Project Title:</b>	Keller Canyon Landfill Land Use Permit Review
<b>County File(s):</b>	#LP89-2020
<b>Applicant/Owner:</b>	Keller Canyon Landfill Company (KCLC) / Republic Services
<b>General Plan/Zoning:</b>	Landfill (LF) / Heavy Agricultural (A-3)
<b>Site Address/Location:</b>	901 Bailey Road, Pittsburg – Bay Point area (APN: 094-060-008, 018, 019, 020 & 021)
<b>California Environmental Quality Act (CEQA) Status:</b>	Exempt (See Section III.C for details)
<b>Project Planner:</b>	David Brockbank, Senior Planner (925) 674-7794
<b>Staff Recommendation:</b>	RECOMMEND that the Board of Supervisors accept this permit review report for the KCL land use permit. (See Section II for Full Recommendation)

### I. PROJECT SUMMARY

This is a public hearing for the County Planning Commission (CPC) to review the existing conditions of approval for Keller Canyon Landfill's (KCL) approved land use permit (LUP) and make recommendations to the Board of Supervisors (Board). This is the second permit review report prepared by staff in accordance with condition of approval 11.1. Permit Review Criteria approved by the Board in 1995 and condition 11.1 affords the Board of Supervisors the opportunity to approve new and/or modified conditions of approval to improve public health, safety, and welfare or to address inconsistencies resulting from court decisions or regulatory changes made since the permit was approved in July 1990. The CPC can recommend that modifications be made to the LUP's conditions, however only the Board has the authority to approve any proposed changes.

The first permit review, initially conducted in 2014, yielded several new conditions and modified many of the original conditions in order to update the LUP after 22 years to reflect the operation of a more mature landfill in the context of present day environmental and regulatory settings. County staff has not identified any need to propose any new or modified conditions of approval as a part of this permit review. This staff report is meant to serve as an update regarding landfill activities regulated by this LUP since the last permit review when the Board approved new and modified conditions, first in December 2014 and finalized in September 2015.

## **II. RECOMMENDATION**

- A. CONSIDER the information presented in this report and Exhibit D, which provides the background and context necessary to satisfy Part I of the 1995 Permit Review Criteria (Exhibit C) approved by the Board of Supervisors for KCL's Land Use Permit (File #LP98-2020).
- B. RECOMMEND that the Board of Supervisors ACCEPT this permit review report prepared by staff for the KCL land Use Permit, pursuant the 1995 Board approved Permit Review Criteria.
- C. RECOMMEND that the Board of Supervisors DIRECT DCD staff to schedule the next permit review in one year.

## **III. GENERAL INFORMATION**

- A. General Plan: Landfill, LF
- B. Zoning: Heavy Agricultural (A-3) and Agricultural Preserve (A-4)
- C. CEQA Status: This permit review does not involve any action that would cause a direct physical change in the environment. This permit review and the preparation and proposed acceptance of the staff report are purely administrative in nature and not subject to CEQA per Section 15061.(b)(3). This action does not constitute a project since staff is not recommending any new or modified conditions of approval for the existing LUP.
- D. Facility Location and Vicinity: KCL is located at 901 Bailey Road, approximately one-half mile south of State Highway 4 in the Pittsburg/Bay Point area. The landfill site covers an area of  $\pm$  2,628 acres (including landfill operations and buffer areas), of which, 244 acres are permitted for disposal (waste placement area). The facility and operations are entirely within

unincorporated Contra Costa County. In addition to the waste placement area, there are also numerous buildings, including administrative offices, maintenance garage, scale house and other installations which make up the complex network of environmental containment systems and facilities required in modern landfills. Those structures and installations include leachate and water storage tanks, enclosed landfill gas control flares, a landfill gas-to-energy power plant, and stormwater/sedimentation management facility. The remainder of the site is predominantly the Special Buffer Area which is undeveloped and helps isolate the landfill from surrounding land uses. The County accepted deeded development rights for the Special Buffer Area which can only be used for grazing or environmental mitigation. Exhibit B contains maps of the facility and vicinity.

#### **IV. BACKGROUND**

County File #LP89-2020 was approved by the Board of Supervisors on July 24, 1990, which allowed the development and operation of the landfill. The initial phase of landfill construction began in 1991 and the landfill opened in May of 1992. County Code Chapter 418-4 requires disposal facilities to obtain a permit approved by the Board of Supervisors. KCL's LUP serves as the permit required under County Code Chapter 418-4. The LUP was subsequently amended by the Board on November 1, 1994, resulting in the addition of a new (replacement) Mitigation Fee condition. Additional conditions governing the construction and operation of a landfill gas power plant were added to the Land Use Permit when the second amendment was approved by the Board on June 25, 2002.

KCL Permit Review: October 2014 - September 2015: The LUP was modified again through the first permit review process, which started with a full report that was presented to the CPC in October 2014. It was a substantive report as it reviewed the past 20 years of the landfill's operations, by addressing each condition of approval in the context of the Board approved Permit Review Criteria. Using said criteria (Exhibit C) staff recommended adding five new conditions and modifying 82 others.

The Board of Supervisors heard the first LUP review report from the CPC on December 16, 2014. Following a lengthy discussion at this meeting, the Board unanimously approved modifications to conditions of approval number 20.3, 25.4, and 31.5. These three conditions were modified from the original land use permit (County File #LP89-2020), and pertained to material used for alternative daily cover (ADC) at the landfill. The Board was not prepared to make a decision on the

remaining recommendations without considering additional information presented to the Board. The permit review was continued to March 3, 2015 as an open public hearing, because the Board directed staff to provide additional information they wanted to consider before acting on the remaining permit review modifications. Staff was directed to research and report back on several additional, separate but related items pertaining to on-site material recovery, legality of the City of Pittsburg taking over as the Local Enforcement Agency (LEA), potential franchise fee impacts expected from a reduction in direct haul loads, and any CEQA implications resulting from the proposed new and modified conditions of approval.

In response to Board direction, staff prepared a detailed report on the Keller Canyon Landfill Permit Review for the March 3, 2015 meeting. On March 3, 2015 the open public hearing was continued to March 31, 2015, and then again to July 21, 2015, at the request of the District V Supervisor. At that meeting, Department of Conservation and Development (DCD) staff recommended that the Board of Supervisors (Board) continue the item once more to September 22, 2015 so that the District V Supervisor could participate in the decision making process. Staff's report to the Board in September 2015 presented detailed explanations on the additional topics mentioned above. It also presented the Board with two separate sets of new and modified conditions as options for the Board to review and then make a decision. The primary difference between the two options were the proposed new conditions, one version allowed loads of mixed construction and demolition (C&D) material to be direct hauled to the landfill contingent upon the implementation of certain on-site waste recovery and the other option required those loads go through a transfer station first. The Board approved the option that limited the direct haul of materials that would be potentially recovered if first delivered to a transfer station in accordance with previously approved Board policy that had not been formerly integrated into the LUP. However, the Board did allow a grace period of 18 months for those four direct haul conditions to take effect following the September 22, 2015 hearing. The grace period allows time for the landfill operator to develop and implement a plan that would address the changes necessary to comply with the new conditions, including any notification process for the customers still hauling those restricted loads directly to the landfill.

**V. PERMIT REVIEW CRITERIA ADOPTED BY THE BOARD IN 1995**

This report serves as the second LUP permit review. The Permit Review Criteria, approved by the Board in 1995, is divided into two parts (see Exhibit C). Part I includes background research to be conducted by staff prior to conducting the public hearing. Part I also provides context related to the permit review authority

and intent, status of existing LUP conditions of approval and other matters. Additional details are provided below to illustrate staff's research as it relates to Part I. Part II outlines the criteria for the actual permit review hearing before the County Planning Commission. In addition, Part II specifies five circumstances that would allow the County to impose new or modified conditions, which are as follows: 1) changes required by new regulations, 2) changes required by court decisions, 3) correction of demonstrated significant health impacts, 4) correction of demonstrated significant safety impacts or 5) correction of demonstrated significant welfare impacts.

### **PART I OF PERMIT REVIEW CRITERIA**

As stated in the Permit Review Criteria, the context for the review is related to applicable laws and regulations that pertain to landfills and other regulatory permits (e.g. Solid Waste Facility Permit, Waste Discharge Requirements. This section includes ensuring that the permit is being implemented, consistent with CEQA and the certified EIR. This section also acknowledges the vested rights of the permittee, and calls for demonstration of compelling public necessity. The following subsections have headings that match the approved Permit Review Criteria (See Exhibit C).

A. Context for the Review: It is the intent of this section to provide a basic setting for this review process. This includes discussing applicable statutory and regulatory framework, relationships between the subject LUP and other regulatory agency permits (e.g. Solid Waste Facilities Permit, Waste Discharge Requirements), and compliance with CEQA.

1. **Applicable Laws and Regulations**: Condition 11.11 states that it "is **not** the Board's intent to establish rules or regulations which are stricter than the laws or regulations which are applied to this project by the other agencies with jurisdiction over aspects of this project." Furthermore, the condition states that the agency with primary jurisdiction has final word about determining if an action or inaction complies with or violates any such law/regulation.

The County acknowledged the rapidly changing regulatory environment related to solid waste management. Condition 11.11 provides some flexibility to help the County respond by allowing the implementation and enforcement of conditions to be adapted in response to regulatory changes which occur between permit reviews. The County has been obligated to adapt the implementation and enforcement of the LUP



conditions accordingly. The County is obligated to adhere to the current regulatory framework, so staff proposed and the Board approved modifications to numerous LUP conditions to address these regulatory inconsistencies in 2015.

Most of the ongoing activities the operator is responsible for in order to remain in compliance with their LUP involve operational requirements that overlap with permits or regulations enforced by Contra Costa Environmental Health (CCEH) and/or the Regional Water Quality Control Board (RWQCB). CCEH is designated as the LEA for the California Department of Resources Recycling and Recovery (CalRecycle). The LEA has direct oversight of the Solid Waste Facility Permit compliance. The LEA conducts unannounced inspections of the landfill each month. Any violations are noted in writing in their official inspection reports.

DCD does not take the lead in enforcing compliance with requirements in regulations or permits governed by other agencies. DCD acts as the enforcement lead when an alleged violation involves a requirement in the LUP conditions that does not overlap with any other regulations or permits. When a potential violation pertains to requirements in the LUP and other permits or regulations, DCD's approach to LUP enforcement is assessed and addressed on a case by case basis. A determination by the applicable authorities regarding the operator's compliance with applicable laws or permits is the best means to substantiate any decision the County may make with respect to a potential violation. If the violation involves a recurring situation that may lead to future undesirable outcomes, the County will clearly indicate what the permittee should do or not do to prevent or avoid similar violations from that point forward.

Generally, DCD defers to other permitting or regulatory agency oversight and determinations on matters for which they have primary jurisdictional authority and responsibility, consistent with the intent of LUP condition 11.11 (see Section IV above).

2. **Terms of Applicable Permits:** Permits and approvals of numerous local, state, and federal agencies were required to construct and operate the Keller Canyon Landfill. KCL is a Class II sanitary landfill and is subject to extensive requirements contained in various permits, laws, regulations and design/operational standards. Some permits were required prior to landfill construction or opening, while others are required for ongoing operations. Each agency permit listed below either discuss the original permit needed

to establish the landfill that has not required subsequent permits or provides the most recent update to that agency's permit.

- a. Solid Waste Facilities Permit (SWFP): The SWFP was last reviewed by County Health Services Department - Environmental Health (LEA) in 2014. According to the LEA, their monthly inspections have demonstrated a consistent track record of compliance since the last permit review. The LEA periodically receives complaints about the landfill, which are mostly about odor or litter. Details about complaints received are usually included in the notes for that monthly inspection report (available on CalRecycle's website). Staff has also included some discussion about complaints over all in Section VI.C of this report.
- b. Waste Discharge Requirements (WDR): RWQCB staff confirmed that the landfill is in compliance with the relevant regulatory/permit requirements. Furthermore, RWQCB staff indicated in September 2016 there are no problems or concerns related to design/construction issues, operational issues, nor had their agency received any complaints about the landfill since the last permit review. RWQCB staff relies on semi-annual self-monitoring reports to gauge KCL's operational compliance (accessible on-line using Geotracker), and they indicated the landfill's next monitoring report would be due in about six months.
- c. Permit to Operate (Air Quality): Authority to Construct/Permit to Operate Plant No. 4618 is reviewed annually by the Bay Area Air Quality Management District (BAAQMD). Additionally, Title V Permit Major Facility Review Plant No. A4618 was last issued on June 12, 2014 by the BAAQMD.
- d. U.S. Environmental Protection Agency: National Pollution Discharge Elimination System Permit #2-07S006887 was issued on September 17, 1992. There have been no changes since the last permit review.
- e. U.S. Army Corps of Engineers: Nationwide Permit No. 26t, Section 404 of the Clean Water Act, was issued on June 14, 1991. There have been no changes since the last permit review.
- f. California Department of Fish and Wildlife: A Streambed Alteration Agreement, No. 1461-90 was signed by the Warden on August 4, 1991 and executed by the Operator on October 18, 1991 for Lawlor Creek; for the sedimentation basin, drainages, and culverts (No. 1462-90); and

for the wetlands construction (No. 1463-90). There have been no changes since the last permit review.

3. **CEQA Compliance & Consistency with Final EIR:** Under the original LUP application approval, the Board of Supervisors adopted a Final EIR, along with a mitigation monitoring and reporting program (MMRP). KCL's development and operation are generally consistent with the original project EIR certified in 1990. Some of the more notable differences are identified below:
  - a. Only a fraction of the disposal tonnage accounted for in the 1990 project EIR was actually going to KCL during its initial years of operation. Although the entire County waste stream was expected to be disposed of at KCL, initially predominantly only Central County waste was going to KCL. The reduced rate of disposal has helped extend the landfill's operating life. The reduced rate of disposal of in-County waste tonnage was partially offset due to subsequent Supreme Court decisions prohibiting restrictions based on waste origin, thus resulting in more out-of-County waste being disposed of at KCL.
  - b. KCL does not entirely rely upon on-site soils as their sole source of daily cover material as assumed in the EIR, due primarily to regulatory changes allowing for the use of alternative daily cover (ADC) materials.
4. **Vested Rights of Permittee:** KCL may operate the Landfill within the parameters of the existing LUP's conditions of approval that were most recently modified on September 22, 2015. This is an entitlement granted by the County for the life of the landfill operation (until permitted capacity is reached). Modifications to the conditions of the permit must be made consistent with applicable legal requirements and in accordance with condition of approval 11.1 and the Board approved Permit Review Criteria. The landfill operator also has the right to request and apply for an amendment to this LUP. An application to amend this LUP was filed in 2008 and is being processed.
5. **Demonstration of Compelling Public Necessity:** As a result of AB 939 and associated revisions to the Public Resources Code (PRC), counties are burdened with the responsibility of maintaining at least a 15-year supply of disposal capacity for all of the waste generated throughout each county. Due to the difficulties and challenges (legal and otherwise) involved with siting a new landfill, the County included permit conditions

and contractual requirements intended to maintain authority to control the amount of out-of-county waste disposed of in the newly sited KCL. That authority has since been diminished as a result of a number of court decisions since 1992, including most recently in 2012/13. Since local jurisdictions can no longer control importation of waste to privately-operated landfills, a host County that receives a significant amount of waste from outside the County will have to undertake the difficult task of identifying new disposal capacity pursuant to the applicable State requirement sooner.

B. Existing Land Use Permit Conditions of Approval: Many of the LUP conditions of approval are intended to mitigate potential on-site and off-site environmental impacts of landfill design and operations. Some of these conditions of approval were the result of impacts/mitigations contained in the EIR prepared for KCL in 1989 and 1990. Additionally, other conditions of approval were developed as part of the Board of Supervisors special conditions, while others attempt to mirror regulatory requirements that are enforced by other agencies as discussed in earlier sections of this report. The LUP contains 288 conditions of approval which are organized into 36 sections (see Exhibit A).

1. **Status of Compliance**: Exhibit D to this staff report is a table listing the compliance status for all 288 conditions of approval. The first two columns are the number and condition. The other two columns reflect the status of each condition and any noteworthy details related to compliance including references to certain source documentation.

Over one-third of the conditions in KCL's LUP do not require any further action because the requirements have been fully satisfied, no longer applicable, informational, simply cross-reference another condition and not meant to be enforced, or serve as objectives for the remaining conditions in a specific section. The remaining conditions are still in effect and contain requirements which may currently apply or may become applicable sometime in the future. Staff has confirmed that the operator is in compliance with the vast majority of the currently applicable conditions.

There are five conditions for which the compliance status determinations are still pending, because they are either in process or require further review. In the context of compliance status, "in process" means that applicable compliance efforts are underway but not yet completed. The conditions which are currently "in process" are 11.1 – Permit Review (which

is the subject of this report), 31.5 – Composting Project, and 36.13 – Power Plant Landscaping Plan. “Further review required” means that the compliance status has yet to be confirmed pending further research and/or coordination with other agencies or parties. The conditions which currently require further review are 31.4 – Material Recovery and 31.6 – Wood Chipping. Details regarding the status of each of these conditions can be found in Exhibit D.

**2. LUP Enforcement:**

Penalties for LUP Violation: If the operator fails to remedy a violation after receiving reasonable notice, the County has two options with respect to penalties. In the case of most LUPs, the sole penalty available for on-going violations is revocation. However, the landfill Franchise Agreement includes a provision allowing the County to impose monetary penalties to aid with LUP enforcement. This provision was included in the Franchise because of the nature of the facility and the public need it serves, including satisfying the County’s obligation under state law to maintain 15-years of in-County disposal capacity.

**3. Monitoring:** Numerous conditions are based on and intended to mirror state or regional regulatory requirements. There are many areas of overlap between the LUP conditions and permits/requirements enforced by CCEH, and other regulatory agencies. Requirements related to landfill design and construction primarily fall under the jurisdiction of the RWQCB. Requirements that govern landfill operations primarily fall under the primary jurisdiction of Contra Costa Environmental Health as the LEA or BAAQMD.

County Code Section 418-4.018 calls for Environmental Health to take the lead for monitoring compliance with disposal site permits issued by the Board of Supervisors, which includes KCL’s LUP. DCD does not routinely inspect the landfill and instead reviews the LEA’s inspection reports. DCD’s monitoring of KCL’s LUP compliance predominantly addresses requirements that are either:

- a. triggered by a one-time or periodic action or event, including requests/proposals submitted by the operator (e.g. proposed construction of the next waste cell within the permitted footprint), or

- b. non-operational matters that primarily involve submittals/documentation, some of which relate to or supplement provisions in KCL's Franchise Agreement (e.g. fees, reporting, etc.)

C. Complaint Review

1. **Complaints to DCD and LEA:** Both agencies have received complaints related to the landfill's operation. The extent of DCD's complaint log about landfill operations is limited to 15 incidents of odor concerns and two incidents of litter control. All of these complaints generally involved coordinated communications between both agencies and follow up investigations by staff.
  - a. Odor Complaints: In early 2015 DCD set up a complaint form on the County's website ([www.cccounty.us/odor](http://www.cccounty.us/odor)) that allows for the electronic submittal of an odor complaint. Once a complaint form is submitted electronically, an email alert is sent to staff from DCD, CCEH, and KCL. DCD Staff worked with the LEA and KCL personnel to investigate and respond to each of the complaints. If a physical address of where the complaint originated or a method of contact was not included, staff could not follow up with a response. This occurred for approximately six out of the 15 on-line complaints, which were received predominantly in early autumn (September and October) and early spring (March and April). Since the complaints sometimes occur in the evening or early morning when the landfill is not operating, these complaints are generally received and responded to on the following day when the potential odor is not discernable and therefore the complaint cannot be verified.
  - b. Litter Complaints: DCD staff received two complaints about litter, one in April 2015 and the other in August 2015. Both complaints were from the same local resident who lives in the neighborhood directly north of the landfill. On both occasions, staff contacted the LEA and KCL personnel to investigate the complaints as well as request data from the on-site weather station in order to check wind speeds and direction. KCL staff and the LEA met with the resident to verify the complaints and address his concerns. After each of the incidents, KCL sent litter cleanup crews to the buffer area near the complainant's residence for several days following the complaints as a precautionary measure in addition to KCL's standard litter management practices,

including on and off-site litter policing and removing litter from the portable and permanent litter fences.

2. **Complaints to Regulatory Agencies:** The BAAQMD operates a toll-free odor complaint hotline which receives calls from throughout the Bay Area which are investigated by agency inspectors. Between January 1, 2015 and August 31, 2016 the District received a total of 37 odor complaints regarding KCL, none of which were confirmed. Limited information regarding these complaints are available to DCD staff, including date, time and one to two word descriptions of the odor (e.g. "bad", "garbage").

BAAQMD received 110 odor complaints between January 2011 and October 2014, which averages out to about 29 complaints per year, and three of those complaints were confirmed. BAAQMD receiving only 37 complaints in the last 20 month period reduces the average annual complaints to about 22, showing a definite reduction of about seven complaints per year.

3. **Complaints to other Local Agencies:** The City of Pittsburg has periodically received complaints about KCL in the past, usually from the residents during annual community meetings conducted near the landfill about night time or early morning odor. DCD staff has not been advised that the City received any complaints since the prior permit review.
4. **Complaints to the Landfill Operator:** Between January 2015 and August 2016, the operator received a total of 11 odor complaints. KCL has procedures for identifying, evaluating, and if confirmed, mitigating odors detected off-site. Site personnel routinely patrol the area including local neighborhoods seeking any indication of odors. Findings and results from the surveys are documented daily. All complaints submitted to KCL, whether by a call from a citizen, or referral by the DCD or BAAQMD, are followed up and investigated by KCL staff. All complaints are tracked and reviewed. If feasible, complainants or nearby neighbors are interviewed.

D. Issues Raised

1. **Construction Issues:**

Phased Construction: Phased Construction of the landfill is authorized by conditions 15.2 & 23.6. Landfill development is being phased over its operating life. Landfill development consists of eight major phases, each containing multiple individual phases. Each individual phase of the waste

placement area is designed/engineered consistent with detailed Design Reports reviewed and approved by the RWQCB. DCD authorizes construction of each individual phase only after it has been approved by the RWQCB. DCD has commissioned reviews by third-party engineering consultant in the initial development stages; recently there has been no need to supplement the RWQCB's review and approval process.

To date, 19 phases have been completed that includes a total of 129.8 acres. Currently, the landfill is working within the 20<sup>th</sup> individual phase, referred to as Phase 3B1 (11.8 acres), which is expected to be in use until 2019.

## 2. **Operating Issues:**

- a. Incoming Waste (Disposal Demand): The amount of waste disposed at KCL has increased substantially since it first opened. The trend of increasing demand for disposal is expected to continue because waste streams are directly impacted by increases in population and economic activity. However, this demand is compounded each time another landfill reaches its capacity because landfills around the state are closing at a rate that far exceeds the siting of new landfills. Another way of looking at this data is to compare the earliest to most recent reporting years, which shows that the amount disposed in 1995 was only 37% of the annual disposal in 2015.
- b. Cover Material: State law was changed after KCL's LUP was issued to allow alternatives to soil for covering disposed waste at the end of each operating day. KCL started a demonstration project using green waste as alternative daily cover (ADC) in 1999 pursuant to oversight by the LEA and CalRecycle. This was subsequently built into the KCL Solid Waste Facility Permit. DCD authorized use of green waste as ADC on an interim basis until such time as the cover requirement in the LUP condition was updated.

At the end of 2014 KCL submitted an application to the LEA to amend their Report for Disposal Information (RDSI) to formally allow unprocessed green waste and processed C&D waste to be used as ADC. In January 2015, the LEA approved the application, which was subsequently appealed by an interested party. The appeal was scheduled for a public hearing before CCEH's Independent Hearing Panel (IHP). The IHP upheld the application approval and denied the



appeal. That decision was also appealed to CalRecycle by the same party. In August 2015, CalRecycle denied the appeal and upheld the decision of the IHP and the LEA's application approval. The interested party has since filed a law suit against CalRecycle (State) and that case is still pending.

- c. Beneficial Reuse: Since the 1990 LUP approval, there have been multiple regulatory changes which opened the door for landfills to implement on-site diversion activities. Specifically, regulations allow operators to beneficially reuse waste derived materials for cover and other on-site uses. According to State regulations, beneficial reuse of solid wastes at a solid waste landfill includes the following: alternative daily cover, alternative intermediate cover, final cover foundation layer, liner operations layer, leachate and landfill gas collection system, construction fill, road base, wet weather operations pads and access roads, and soil amendments for erosion control and landscaping. KCL continues to take direct haul loads of eligible source-separated materials that can be used for beneficial reuse on-site.
- d. Application for LUP Amendment #3: Increases in disposal tonnage prompted the operator to file an application to amend the LUP in 2008 primarily seeking to increase the daily tons per day (TPD) limit. The subsequent economic downturn decreased the flow of incoming waste which has helped afford more time to work through a variety of time-consuming issues related to better defining and reviewing the request. The project description has also been changed a couple of times and may be changed again pending the outcome of the operator's assessment of the viability of implementing some type of on-site material recovery operation. The application is still in process, and will require additional CEQA review, including the preparation of a subsequent EIR.

### 3. **Special Waste Issues:**

- a. Limitation on Special Waste Disposal: In December 1993, the Board authorized the import of special wastes for disposal in Keller Canyon Landfill pursuant to specific guidelines. Such authorization included a limitation such that special wastes generated from within and outside of Contra Costa County together comprised no more than 40% of the total waste disposed at KCL in any 12-month period. In 2015, special

wastes (also referred to as Class II or designated wastes) only comprised 7% of the total disposal at KCL.

- b. PG&E Property Clean-up, Bay Point: Since the last permit review, PG&E contracted with a special waste hauler to assist cleaning up the Shell Pond site, east of the old Harris Yacht Harbor, located north of the railroad tracks, and east of the McAvoy Harbor in Bay Point. Part of the clean-up involved hauling non-hazardous, contaminated soil from this previous settling pond. In the process of hauling the soil material involved extracting the wet soil from the site, which had a very strong odor, stock piling the soil to dry then trucking the material to KCL for disposal. This special waste project consisted of hauling approximately 20-30 truckloads per day of this contaminated soil for about two weeks. DCD staff did not receive any complaints about odors or spilled material resulting from this project.
4. **Haul Route Issues:** There have been no issues with respect to the Haul Route since the last permit review.
5. **Transfer Station Issues:** A number of different Transfer Stations have sent waste to KCL over its operational life to date, including those in and outside of our County. Waste that is transferred for disposal from other transfer stations located outside the County changes periodically. Since the last permit review, all of the waste transferred for disposal from the four in-County transfer stations (Brentwood, unincorporated Martinez, North Richmond, and Pittsburg) was sent to KCL.
6. **Direct Haul:** The project description which served as the basis for issuance of KCL's LUP as well as the environmental analysis in its 1989/1990 EIR anticipated only small amounts of waste being direct hauled to KCL. All waste that could be processed at Transfer Stations was expected to be sent to such facilities and then subsequently accepted at KCL by way of a transfer trailer/van. This method of managing solid waste was integral to achieving waste diversion goals because processing at Transfer Stations enables the waste stream to be sorted. The transfer station method also effectively controlled traffic (and associated impacts). Although traffic has been controlled by the daily vehicle limit specified in the Solid Waste Facility Permit, no similar alternative solution is in place to address waste diversion.

The Board took actions in 1992-1993 to specifically address issues related to direct haul and import of special wastes. These parameters were used to develop new conditions (conditions 8.5-8.8), which were approved in 2015 as part of the prior permit review. These four conditions account for allowable materials that can still be direct hauled to the landfill, procedures necessary for processing direct hauled material(s), specific quarterly reporting requirements, and in the event of an emergency or natural disaster, how and what can be direct hauled to the landfill. These conditions do not take effect for 18 months (from 9/22/2016).

**VI. PART II OF PERMIT REVIEW CRITERIA FOR COUNTY PLANNING COMMISSION**

The permit review condition 11.1 was included to address the County's anticipated need for future flexibility to improve upon the conditions in KCL's LUP. LUP condition 11.1 states that conditions can be added or modified to improve public health, safety and welfare, which are three of the five criteria specified in Part II of the Permit Review Criteria that were approved by the Board of Supervisors in 1995 (Exhibit C). As it was expected when the permit was initially approved, the knowledge gained from actual experience working with and regulating an operating landfill has proven to be quite valuable when taking a critical look at the LUP to identify modifications needed to improve public health, safety and welfare. Such changes were approved in the prior permit review, but no such changes are recommended as a result of the current permit review.

Regulatory changes and court decisions are the last two of the five criteria specified in Part II of the Board approved 1995 Permit Review Criteria. Both criteria serve as key elements of the legal framework governing the manner in which the County and the landfill must operate. Unlike the other three criteria, these two may have a direct impact on numerous LUP conditions as originally written. In some cases these changes result in eliminating the County's ability to enforce certain requirements or created inconsistencies with regulations the specified conditions were intended to mirror or reinforce. These two criteria were added to condition 11.1 in 2015 during the prior permit review. Staff is not proposing to add or modify any new or existing conditions related to regulatory changes as part of this permit review.

**VIII. CONCLUSION**

Staff recommends that the CPC recommend that the Board of Supervisors accept this permit review report and Exhibit D as adequate to satisfy Parts I and II of the Board approved 1995 Permit Review Criteria.

**LIST OF EXHIBITS:**

- Exhibit A: Existing conditions from 2014/2015 Permit Review – September 2015
- Exhibit B: Maps
- Exhibit C: Permit Review Criteria - June 1995
- Exhibit D: Compliance Status Table -- September 2016

**LAND USE PERMIT 2020-89**  
**CONDITIONS OF APPROVAL**  
**KELLER CANYON LANDFILL**

Approved by the:  
*CONTRA COSTA COUNTY BOARD OF SUPERVISORS*  
JULY 24, 1990

As Amended or Modified by the:  
*CONTRA COSTA COUNTY BOARD OF SUPERVISORS*  
November 1, 1994 (Amendment 1)  
June 25, 2002 (Amendment 2)  
December 16, 2014 (Permit Review Modification)  
September 22, 2015 (Permit Review Modification)

## TABLE OF CONTENTS

<b>1.</b>	<b>SHORT TITLE .....</b>	<b>1</b>
1.1	Short Title .....	1
<b>2.</b>	<b>RESPONSIBILITY .....</b>	<b>1</b>
2.1	Ultimate Responsibility.....	1
2.2	Transfer of Ownership .....	1
2.3	Assignment of Responsibility .....	1
<b>3.</b>	<b>COMPLIANCE.....</b>	<b>2</b>
3.1	Compliance Objective .....	2
3.2	Design Standard .....	2
3.3	State Minimum Standards .....	2
3.4	Land Use Permits .....	2
3.5	Solid Waste Facilities Permit.....	2
3.6	Class II Landfill Requirements .....	2
3.7	Other Regulatory Agencies' Requirements .....	2
3.8	Utilities, Service Districts, and Government Agencies' Requirements.....	2
3.9	Notice Coordination .....	3
3.10	Monitoring and Inspection.....	3
3.11	Master Chart.....	3
<b>4.</b>	<b>VALIDITY PERIOD.....</b>	<b>3</b>
4.1	Validity Period.....	3
4.2	Operative Date.....	3
<b>5.</b>	<b>SERVICE AREA .....</b>	<b>3</b>
5.1	Area of Origin.....	3
5.2	Out-of-County Wastes .....	4
5.3	Sub-County Service Area .....	4
5.4	Reciprocal Capacity Agreement .....	4
5.5	Pre-Requisite Curbside Recycling Program.....	4
<b>6.</b>	<b>ELIGIBLE AND INELIGIBLE WASTES.....</b>	<b>4</b>
6.1	Eligible Wastes .....	4
6.2	Designated Wastes.....	5
6.3	Infectious Wastes .....	5
6.4	Ineligible Wastes.....	5
6.5	Emergency Use .....	5
6.6	Hazardous Waste Screening and Management .....	5
6.7	Area of Origin Restrictions .....	5
<b>7.</b>	<b>LOAD INSPECTION.....</b>	<b>6</b>
7.1	Eligible Vehicles and Loads .....	6
7.2	Load Covering .....	6
<b>8.</b>	<b>ELIGIBLE REFUSE TRANSPORT VEHICLES .....</b>	<b>6</b>
8.1	Eligible Vehicles.....	6

8.2	Service Area Restriction .....	7
8.3	Emergency Exemption.....	7
8.4	Reciprocal Use Exemption.....	7
8.5	Direct Haul.....	7
8.6	Direct Haul Procedures.....	7
8.7	Direct Haul Reports .....	9
8.8	Emergency Direct Haul.....	9
<b>9.</b>	<b>OPERATING PARAMETERS .....</b>	<b>9</b>
9.1	Hours of Operation .....	9
9.2	Operating Days.....	10
9.3	Maximum Daily Tonnage.....	10
9.4	Minimum Buffer Zone .....	10
9.5	Special Buffer Area.....	10
9.6	Dedication of Special Buffer Area .....	10
<b>10.</b>	<b>WASTE MEASUREMENT AND CHARACTERIZATION .....</b>	<b>11</b>
10.1	Volume Estimation.....	11
10.2	Scales.....	11
10.3	Waste Characterization.....	11
<b>11.</b>	<b>ADMINISTRATION.....</b>	<b>12</b>
11.1	Permit Review.....	12
11.2	Local Advisory Com.....	12
11.3	Insurance and/or Bonding.....	12
11.4	Notification Program .....	13
11.5	Development Coordinator.....	13
11.6	Compliance and Mitigation Monitoring Program .....	13
11.7	Pre-Annexation Notification .....	13
11.8	Fee and Surcharge Identification .....	14
11.9	Interpretation of Conditions.....	14
11.10	Conditions Requiring Franchise.....	14
11.11	Regulations Enforced by Other Agencies .....	14
11.12	Required Expenditures .....	14
11.13	Designation of Authority.....	15
<b>12.</b>	<b>RATE REVIEW .....</b>	<b>15</b>
12.1	Rate Approval.....	15
12.2	Rate Review .....	15
12.3	Form and Content of Rate Review Application .....	15
12.4	Rate Application Guidelines.....	16
12.5	Financial Statement .....	16
12.6	Scope of Rates .....	16
<b>13.</b>	<b>FRANCHISE AGREEMENT.....</b>	<b>16</b>
13.1	Franchise Compliance and Agreement.....	16
13.2	Assignment.....	17
13.3	Contents .....	17
13.4	Requirement .....	17
13.5	County Discretion .....	17

<b>14.</b>	<b>LAND USE PERMIT PLAN CONSTITUENTS.....</b>	<b>17</b>
14.1	Initial Development and Improvements Plan.....	17
14.2	Regulatory Agency Approvals.....	18
14.3	Improvements Requirements.....	18
<b>15.</b>	<b>DEVELOPMENT AND IMPROVEMENTS PLAN .....</b>	<b>19</b>
15.1	Final Development and Improvements Plan .....	19
15.2	In approving the Development and Improvements Plan .....	19
<b>16.</b>	<b>SLOPE AND SEISMIC STABILITY .....</b>	<b>20</b>
16.1	Landfill Slopes Objective.....	20
16.2	Seismic Design.....	20
16.3	Landslide Study .....	20
16.4	Geotechnical Inspector .....	20
16.5	Landfill Design Stability.....	20
16.6	Slope Monitoring.....	20
16.7	Settlement Program.....	21
16.8	Emergency Landslide and Earthquake Program .....	21
16.9	Settlement Pond Embankment Design.....	21
16.10	Settlement Pond(s) Monitoring Program.....	21
16.11	Stockpile Stability.....	21
16.12	Unstable Areas .....	21
<b>17.</b>	<b>GROUNDWATER PROTECTION.....</b>	<b>21</b>
17.1	Groundwater Protection Objective .....	21
17.2	Landfill Liner .....	22
17.3	Leachate Collection System .....	22
17.4	Surface Drainage System.....	22
17.5	Groundwater Monitoring .....	22
17.6	Downstream Well Monitoring.....	22
17.7	Baseline Water Characterization .....	23
17.8	Liquid Waste Disposal .....	23
17.9	Drainage Grading .....	23
17.10	Leachate Management.....	23
17.11	Water Balance Calculations.....	23
17.12	Leachate Holding Tanks .....	23
17.13	On-Site Water Supply Wells .....	24
17.14	Off-Site Water Well Contamination .....	24
17.15	Liner Installation Inspection.....	24
17.16	Secondary Containment .....	24
17.17	Working Face.....	24
<b>18.</b>	<b>SURFACE WATER PROTECTION .....</b>	<b>24</b>
18.1	Surface Water Protection Objective.....	24
18.2	Surface Drainage System.....	25
18.3	Creek Protection .....	25
18.4	Surface Water Management and Sediment Control Plan .....	25
18.5	Monitoring.....	26



<b>19.</b>	<b>HAZARDOUS WASTE</b> .....	<b>26</b>
19.1	Hazardous Waste Ineligible .....	26
19.2	Load Inspection .....	26
19.3	Household Hazardous Waste Program .....	27
19.4	Hazardous Waste Pre-screening.....	27
19.5	Regulatory Agency Approvals.....	27
<b>20.</b>	<b>AIR QUALITY PROTECTION</b> .....	<b>27</b>
20.1	Prevention of Air Quality Deterioration .....	27
20.3	Cover Frequency. ....	28
20.4	Odoriferous Loads .....	29
20.5	Dust Suppressants .....	29
20.6	Area of Operations.....	29
20.7	Air Flow Monitoring .....	29
20.8	Contingency Program .....	29
20.9	Revegetation.....	29
20.10	Tree and Shrub Planting .....	30
20.11	Gas Control and Collection .....	30
20.12	Landfill Gas Processing .....	30
20.13	Methane Recovery.....	30
20.14	Gas Monitoring .....	31
20.15	Lateral Gas Barriers.....	31
20.16	Settlement Protection.....	31
20.17	Landfill Gas Testing .....	31
20.18	Leachate Disposal .....	31
20.19	Cell Re-Opening .....	31
20.20	Fissure Repair .....	31
20.21	Permanent Road Paving.....	32
20.22	Temporary Road Paving.....	32
20.23	Speed Limits .....	32
20.24	Equipment Maintenance .....	32
<b>21.</b>	<b>NOISE CONTROL</b> .....	<b>32</b>
21.1	Noise Control Objective .....	32
21.2	Noise Monitoring Program .....	32
21.3	Toe Berm.....	33
21.4	Mitigation/Lift-Level Berms.....	33
21.5	Construction Hours .....	33
21.6	Truck Noise Suppression.....	33
21.7	Landfill Vehicles.....	33
21.8	Gas Flare Muffling .....	33
<b>22.</b>	<b>VISUAL QUALITY</b> .....	<b>33</b>
22.1	Visual Quality Objective .....	33
22.2	Landscape Plan.....	33
22.3	Toe Berm.....	34
22.4	Mitigation Berms .....	34
22.5	Lawlor Creek Corridor Plan.....	34
22.6	Entrance Screening .....	34
22.7	Jacqueline Drive Terminus .....	34
22.8	Auxiliary Facilities Screening .....	34

22.9	Architectural Treatment.....	34
22.10	Area of Operations.....	35
22.11	Interim Revegetation.....	35
22.12	Water Tank Screening.....	35
22.13	Final Cover .....	35
22.14	Lighting .....	35
<b>23.</b>	<b>AGRICULTURAL AND BIOTIC RESOURCES .....</b>	<b>35</b>
23.1	Biotics Protection Objectives .....	35
23.2	Range Management Plan.....	36
23.3	Lawlor Creek Corridor Restoration Plan .....	36
23.4	Sandstone Outcrop Area .....	37
23.5	Weed Control Program .....	37
23.6	Phased Construction .....	37
23.7	Vegetation Protection.....	37
23.8	Wildlife Exclusion and Vector Control .....	37
23.9	Supplemental Wildlife Surveys .....	37
<b>24.</b>	<b>BIRD AND VECTOR CONTROL .....</b>	<b>38</b>
24.1	Bird and Vector Control Objective.....	38
24.2	Soil Cover Frequency .....	38
24.3	Working Face.....	38
24.4	Bird Control.....	38
24.5	Rodent Control.....	38
24.6	Mosquito Control.....	39
24.7	Fly Control .....	39
<b>25.</b>	<b>LITTER CONTROL.....</b>	<b>39</b>
25.1	Litter Control Objective .....	39
25.2	Load Covering .....	39
25.3	Load Cover Enforcement.....	39
25.4	Contingency Litter Control .....	39
25.5	Portable Litter Fences.....	40
25.6	Permanent Litter Fence .....	40
25.7	On-Site Litter Policing .....	40
25.8	Off-Site Litter Policing .....	40
25.9	Littering Signs .....	40
25.10	Clean-Up Bond.....	40
25.11	Public access.....	40
<b>26.</b>	<b>PUBLIC HEALTH AND SAFETY .....</b>	<b>41</b>
26.1	Safety Objective.....	41
26.2	Emergency Plan .....	41
26.3	Employee Safety Equipment .....	41
26.4	Employee Training.....	41
26.5	First Aid Equipment .....	41
26.6	Emergency Communications.....	41
26.7	Emergency Eye Baths and Showers .....	41
26.8	Equipment Maintenance .....	42
26.9	Gas Migration Monitoring.....	42
26.10	Refuse Cover.....	42

26.11	Load Inspection .....	42
<b>27.</b>	<b>SITE SECURITY .....</b>	<b>42</b>
27.1	Security Objective .....	42
27.2	Security Fencing .....	42
27.3	Security Staffing .....	42
27.4	Security Lighting .....	42
<b>28.</b>	<b>CULTURAL RESOURCES .....</b>	<b>43</b>
28.1	Cultural Resource Preservation Objective .....	43
28.2	Employee Access .....	43
28.3	Archaeology .....	43
<b>29.</b>	<b>TRANSPORTATION AND CIRCULATION .....</b>	<b>43</b>
29.1	Traffic Objective .....	43
29.2	Access Route .....	43
29.3	Landfill Access Road .....	43
29.4	Landfill Entrance .....	44
29.5	Bailey Road, Pittsburg city limits to the Landfill Entrance .....	44
29.6	Bailey Road Pavement Study .....	44
29.7	Road Maintenance .....	45
29.8	Highway 4/Bailey Road Interchange .....	45
29.9	Peak Period Traffic Management .....	45
29.10	Bicycle and Pedestrian Improvements .....	46
<b>30.</b>	<b>SITE SERVICES AND UTILITIES PLAN .....</b>	<b>46</b>
30.1	Final Site Services and Utilities Plan .....	46
30.2	Water Service Component .....	46
30.3	On-site Water Wells .....	46
30.4	Public Water Supply Option .....	47
30.5	Fire Protection Component .....	47
30.6	Fire District Programs .....	47
30.7	Construction Timing .....	47
30.8	On-Site Water Storage .....	47
30.9	Fire Fighting Water Main .....	47
30.10	Fire Cover .....	48
30.11	Fire Fighting Appliance .....	48
30.12	Fire Breaks .....	48
30.13	Fire Extinguishers .....	48
30.14	Use of Reclaimed Water for Landscaping .....	48
30.15	Equipment and Cleaning .....	48
30.16	Smoldering Loads .....	48
30.17	Emergency Equipment Access .....	48
30.18	Smoking Prohibitions .....	49
30.19	Toilets .....	49
30.20	On-site Septic System .....	49
30.21	Sewer Line .....	49
<b>31.</b>	<b>WASTE REDUCTION AND RESOURCE RECOVERY .....</b>	<b>49</b>
31.1	Waste Reduction and Resource Recovery Objective .....	49
31.2	1990-1995 Resource Recovery Program .....	49

31.3	1996-2000 Resource Recovery Program .....	49
31.4	Materials Recovery .....	49
31.5	Composting Project .....	50
31.6	Wood Chipping .....	51
31.7	Methane Recovery.....	51
31.8	Equipment Maintenance .....	51
31.9	County Resource Recovery Management Program .....	51
31.10	Fund Recovery .....	51
<b>32.</b>	<b>CONSTRUCTION ACTIVITIES AND CONDITIONS .....</b>	<b>52</b>
32.1	Hours of Construction .....	52
32.2	Exemption.....	52
32.3	Access Roads.....	52
32.4	Phasing Plan.....	52
32.5	Unstable areas.....	52
32.6	Dust Suppression .....	52
<b>33.</b>	<b>CLOSURE AND POSTCLOSURE MAINTENANCE .....</b>	<b>53</b>
33.1	Submittal of Plan.....	53
33.2	Funding of Closure and Postclosure Maintenance Plan .....	53
33.3	Revision to Plan and Cost Estimates .....	53
33.4	Staged Closure of the Landfill.....	53
33.5	Use of Landfill Following Closure.....	53
33.6	Postclosure Maintenance .....	54
<b>34.</b>	<b>ABANDONED VEHICLE STORAGE.....</b>	<b>54</b>
34.1	Storage Requirement.....	54
34.2	Off-site Storage Option .....	54
<b>35.</b>	<b>SPECIAL CONDITIONS OF APPROVAL .....</b>	<b>54</b>
35.1	Transportation System Impact Fee.....	54
35.2	Open Space and Agricultural Preservation Fee.....	54
35.3	Property Value Compensation Program .....	55
35.4	Resource Recovery Program Fee .....	55
35.5	Violation of Prescribed Haul Route .....	55
35.6	Direct Property Acquisition Study.....	56
35.7	Adjoining Sites.....	56
35.8	Mitigation Fee .....	56
<b>36.</b>	<b>LANDFILL GAS POWER PLANT .....</b>	<b>57</b>
36.1	Power Plant Design .....	57
36.2	Ultimate Responsibility.....	57
36.3	Keller Canyon Landfill Land Use Permit .....	57
36.4	Violation/Revocation .....	57
36.5	System Safety.....	57
36.6	Equipment and System Monitoring .....	57
36.7	Engines.....	57
36.8	Hazardous Materials.....	57
36.9	Emergency Response .....	58
36.10	Notification of Plant Upset or Accidental Release .....	58
36.11	Stormwater Pollution Prevention Plan (SWPPP) .....	58

36.12	Facility Design .....	58
36.13	Power Plant Landscape Plan.....	58
36.14	Construction.....	58
36.15	Material Recycling. ....	58
36.16	Implementation & Compliance Monitoring. ....	58
36.17	Surcharge. ....	58
<b>History of Revisions .....</b>		<b>59</b>

## 1. SHORT TITLE

- 1.1 Short Title. The Keller Canyon Landfill project is henceforth referred to in this document as the Landfill.

## 2. RESPONSIBILITY

- 2.1 Ultimate Responsibility. The conditions of approval identify the Landfill developer as the party responsible for implementing conditions involving construction and improvements, and the Landfill operator for implementing conditions involving maintenance and management. Regardless of these identifications, the Landfill owner shall be responsible for complying with all conditions.
- 2.2 Transfer of Ownership. The Land Use Permit for the Landfill shall run with the land; however, a new owner shall be responsible for notifying the County Conservation and Development Department of any change in ownership. A change in ownership shall be interpreted to mean the acquisition of 5 percent or more of the value of the Landfill site covered by this Land Use Permit. (It is noted that other permits may not necessarily run with the land.)
- 2.3 Assignment of Responsibility.
- a) The Board may assign the responsibility of administering specific Conditions of Approval or provisions of this LUP, such as State Minimum Standards, to County Departments or other units of government.
  - b) The Board may suspend the implementation of conditions or provisions of this LUP where such conditions or provisions are inconsistent with the terms of a contract or agreement entered into between the Board and the operator or other units of government, or by the terms of a joint powers agreement where the County is a member of the joint powers agency. This would not alleviate the need to comply with the public approval process required when amending this LUP. Any Board approved suspension would automatically be nullified at such time as the contract or agreement no longer includes terms inconsistent with the specified condition.
  - c) For the purposes of Condition 2.3(b), the Franchise Agreement between the County and the Landfill Owner as amended in November 1994, is an eligible contract.
  - d) If no contract or agreement is in force, as referred to in Condition 2.3(b), the County retains authority to implement this LUP and all of its Conditions.

### **3. COMPLIANCE**

- 3.1 Compliance Objective. The Landfill developer and operator shall at all times comply with the requirements of laws and permits applicable to the facility. This condition is not intended to grant authority or assign responsibility to the County for the independent enforcement of regulatory and permitting requirements that fall within the primary jurisdiction of other agencies (see Condition 11.11).
- 3.2 Design Standard. The Landfill developer shall design the Landfill facility to meet the requirements of the San Francisco Regional Water Quality Control Board for a Class II waste disposal facility.
- 3.3 State Minimum Standards. The operation and maintenance of this facility shall at all times comply with Minimum Standards for Solid Waste Handling and Disposal (California Code of Regulations, Title 14 and Title 27).
- 3.4 Land Use Permits. The Landfill developer and operator shall at all times comply with the provisions and requirements of this Land Use Permit. A violation of any of these conditions may be cause for revocation of the Land Use Permit pursuant to County Code Section 418-4.020 following reasonable written notice. Alternatively, the County has the option of issuing formal notices and assessing penalties pursuant to Section 4.19 of the Landfill Franchise Agreement or County Code Chapter 14-6, Civil Enforcement.
- 3.5 Solid Waste Facilities Permit. The Landfill operator shall conform with all provisions and requirements of the Landfill's Solid Waste Facilities Permit, and any related directives of the California Department of Resources Recycling and Recovery (CalRecycle) or Contra Costa Environmental Health, as the Local Enforcement Agency for CalRecycle.
- 3.6 Class II Landfill Requirements. The Landfill operator shall at all times comply with the Class II waste disposal facility provisions and requirements of Article 3, Chapter 15 of Title 23 and Title 27 of the California Code of Regulations.
- 3.7 Other Regulatory Agencies' Requirements. The Landfill operator shall at all times comply with the provisions and requirements of other regulatory agencies having jurisdiction over the facility.
- 3.8 Utilities, Service Districts, and Government Agencies' Requirements. The Landfill developer or operator shall at all times comply with the regulations and requirements of utilities, districts, or agencies which have jurisdiction over the installation of improvements or provide services to the landfill.

- 3.9 Notice Coordination. The Landfill operator shall notify the Department of Conservation and Development (DCD) in writing at the time any report is submitted to other agencies concerning the design, operation, and maintenance of the Landfill. Copies shall be made available or mailed to DCD offices at 30 Muir Road in Martinez upon request.
- 3.10 Monitoring and Inspection. All monitoring reports and results of inspection or analysis shall be made available to the Contra Costa Environmental Health and Conservation and Development Departments. Any indication of an emergency or other serious problem relating to public health and safety shall be reported at once.
- 3.11 Master Chart. The Landfill operator will maintain for reference a master chart showing schedules and results of preparation, operation, monitoring and reporting in all major phases of the facility.

#### **4. VALIDITY PERIOD**

- 4.1 Validity Period. The Landfill developer shall install pre-requisite improvements and open the Landfill for receiving refuse within three years of the final approval of the project's Solid Waste Facilities Permit. This validity period shall be tolled while any appeal filed by parties other than the Landfill developer is pending. The Landfill developer may request from the Director of Community Development one or more one-year extensions of the Land Use Permit. If the Land Use Permit is not implemented within the specified time, it shall become null and void. The Director of Community Development may allow each one-year extension if the Director finds that there are changed circumstances which warrant the consideration of changes to the Conditions of Approval.
- 4.2 Operative Date. This Land Use Permit is valid upon approval by the Board of Supervisors. However, it shall not become operative until and unless the permittee (landfill owner, etc.) first obtains and the Board of Supervisors grants a franchise to or approves an agreement with permittee (see Section 13, Franchise Agreements).

#### **5. SERVICE AREA**

- 5.1 Area of Origin. The Landfill operator shall not refuse to receive eligible wastes or cover materials which originate in Contra Costa County provided such wastes or materials are delivered to the facility in accordance with these Conditions of Approval and the landfill's Solid Waste Facilities Permit,



and provided that the required governmental fees are paid. Rate setting requirements are specified in the Landfill Franchise Agreement and Section 12 of this Land Use Permit.

5.2 Out-of-County Wastes. *INVALIDATED BY LEGISLATURE*

5.3 Sub-County Service Area. If there is more than one Class II or Class III landfills operating in Contra Costa County, the Board of Supervisors may establish sub-County service areas for each on a temporary or long-term basis. If the Board has established a sub-County service area for the Landfill, the operator shall not accept waste for disposal from outside such area.

5.4 Reciprocal Capacity Agreement. The Landfill operator shall receive waste from outside Contra Costa County if in accordance with the terms and conditions of a Reciprocal Capacity Agreement entered into by Contra Costa County with another county. Waste shall be received upon reasonable notice to the Landfill operator and the Board of Supervisors and direction by the Board to the Landfill operator as to the terms and conditions under which the waste will be received. The Board may specify disposal charges which are applicable only to the waste received under the Reciprocal Capacity Agreement.

5.5 Pre-Requisite Curbside Recycling Program. The Landfill shall not admit for disposal waste loads from communities which do not have an eligible curbside recycling or equivalent program as determined by the Department of Conservation and Development. An eligible program shall recover a range of recyclable materials consistent with a curbside recycling program operating pursuant to a Board of Supervisors-approved franchise agreement.. The Board of Supervisors has the discretion to identify additional factors to be considered when determining eligibility. The Board retains the authority to approve community programs previously deemed to be ineligible by the Department of Conservation and Development.

## 6. ELIGIBLE AND INELIGIBLE WASTES

6.1 Eligible Wastes. The Landfill operator shall allow only wastes eligible for disposal in a Class II facility, as defined by the Regional Water Quality Control Board to be admitted to the landfill. The wastes admitted to the landfill shall also be consistent with the Solid Waste Facilities Permit (07-AA-0032), administered by Contra Costa Environmental Health, and consistent with the 1990 Environmental Impact Report and Board of Supervisors' policies and approvals (including the Board of Supervisors conditional authorization in 1992-93 to accept special wastes and limited direct haul –

see Conditions 8.5 through 8.7) and these conditions of approval. To the extent allowed by law, the Board of Supervisors may direct the Landfill operator not to accept wastes that do not meet State and County policies and regulations.

- 6.2 Designated Wastes. The Landfill operator shall allow only those designated wastes (as defined in Section 20210 of Title 27, of the California Code of Regulations and Section 13173 of the California Water Code) approved for this facility by the San Francisco Regional Water Quality Control Board, and shall be consistent with the waste types allowed for disposal pursuant to Condition 6.1. The Board of Supervisors may designate special rates for this waste to the extent allowed pursuant to the terms of the Landfill Franchise Agreement.
- 6.3 Infectious Wastes. The Landfill operator shall accept only those infectious wastes identified in, and disposed of in accordance with the Solid Waste Facilities Permit.
- 6.4 Ineligible Wastes. The Landfill operator shall not allow the following wastes to be disposed at the landfill:
  - a) Hazardous or toxic wastes.
  - b) Radioactive wastes.
  - c) Liquid wastes, other than utility sludges meeting Regional Water Quality Control Board requirements.
  - d) Other ineligible wastes specified in the Solid Waste Facilities permit administered by the Contra Costa Environmental Health.
- 6.5 Emergency Use. If the service area of the Landfill is determined to be a sub-area of the County, the County Department of Conservation and Development or Contra Costa Environmental Health may allow legal waste originating in areas of Contra Costa County, other than those stipulated in Section 5, to have access to the landfill for periods up to 180 days on an emergency basis. The department(s) may grant one extension for no longer than 180 days. The Board of Supervisors may allow the emergency use of the landfill to continue for any time period deemed necessary.
- 6.6 Hazardous Waste Screening and Management. See Condition 19.
- 6.7 Area of Origin Restrictions. See Condition 5.

## **7. LOAD INSPECTION**

- 7.1 Eligible Vehicles and Loads. The Landfill operator shall screen loads to limit to the extent practicable the intake of ineligible waste. Prior to receiving waste, the Landfill operator shall prepare in writing a program for identifying eligible vehicles and screening loads at the Landfill entrance, random sampling and inspection for ineligible wastes, and checking loads at the Landfill disposal area. The Load Inspection program shall include inspection for hazardous wastes and procedures for their handling and off-site disposal consistent with the Contra Costa County Hazardous Waste Management Plan. The program shall be subject to the approval of Contra Costa Environmental Health and the County Conservation and Development Department.
- 7.2 Load Covering. The Landfill operator shall spot check all incoming waste-hauling vehicles for proper covering or containerization consistent with the requirements of Section 418-2.008(a) of the County Code. The operator shall identify any waste loads which are susceptible to littering or leakage because of the lack of covering, inadequate covering, or disrepair of screens, covers or containers. Customers delivering any such waste loads shall be required to provide evidence that corrective actions have been taken to effectively cover and contain waste loads (e.g. waste adequately secured with covers and containers in good repair) in order to be eligible to deliver waste loads in the future. Landfill operator shall track and report applicable details about the occurrences and corrective actions taken to the County Department of Conservation and Development annually.

## **8. ELIGIBLE REFUSE TRANSPORT VEHICLES**

- 8.1 Eligible Vehicles. The Landfill operator shall admit only the following refuse transport vehicles:
- a) Transfer station trucks (vans). Transfer stations shall have a Waste Management Program, which includes hazardous waste screening and resource recovery operations. Program may be subject to the approval of the Board of Supervisors if deemed necessary for consistency with the Countywide Integrated Waste Management Plan.
  - b) Demolition and construction material trucks hauling debris that would not be recycled or otherwise diverted from disposal if processed at a local Transfer Station. There are waste reduction requirements that apply to such wastes generated by businesses and industries, therefore the operator shall assist the County to help ensure compliance with such requirements or goals through implementation

and compliance with Conditions 8.5 – 8.7.

- c) Incinerated sewage sludge-hauling trucks originating at utilities.
- d) Sewage and water treatment plant sludge and other byproduct trucks with loads complying with San Francisco Regional Water Quality Control Boards solids-to-liquid requirements.
- e) Trucks hauling Designated Wastes approved for this landfill by the Regional Water Quality Control Board.
- f) Other specialized waste transport trucks, hauling wastes identified in the Landfill's Solid Waste Facilities Permit which cannot be feasibly processed to increase diversion through a Transfer Station.

8.2 Service Area Restriction. See Section 5.

8.3 Emergency Exemption. See Condition 6.5.

8.4 Reciprocal Use Exemption. See Condition 5.4.



8.5 Direct Haul. Only wastes in the prescribed vehicles which would not be recycled or otherwise diverted from disposal if processed through a local transfer station may be considered for direct haul pursuant to the Procedures specified in Condition 8.6. At least once per year, the Landfill operator shall submit an updated list of waste and material types recovered prior to transfer for disposal at the landfill if contained in loads delivered to any of the local transfer stations open to the public. The annual list shall be subject to the review and approval of the Department of Conservation and Development and is intended to be used when screening direct haul eligibility pursuant to Condition 8.6(g). Loads containing materials that will be used as cover or otherwise beneficially reused on-site and treated as diversion under the Integrated Waste Management Act may be direct hauled without going through a transfer station.



***New Conditions 8.5 – 8.8 do not take effect until 18 months from September 22, 2015, pursuant to the Board of Supervisors approval in conjunction with the Permit Review for Land Use Permit 2020-89.***

8.6 Direct Haul Procedures. Direct haul process and materials shall be consistent with the Solid Waste Facility Permit (No. 07-AA-0032), this LUP, and applicable policies adopted by the Board of Supervisors including those identified in 8.6(k) below. The operator shall ensure new customers receive information consistent with i) and j) prior to gaining access to the site. The operator shall conduct screening procedures specified in a) through h) prior to allowing customers to direct haul waste/material loads to the landfill. Operator shall provide written confirmation that eligibility has been demonstrated consistent with these procedures prior to loads being accepted for disposal. Operator shall summarize results of direct haul

eligibility screening completed each quarter in the direct haul reports required under Condition 8.7.

- a) Name of company and physical location at which the waste or material was generated.
- b) Complete description of waste including chemical analysis and solids-to-liquid ratio when appropriate.
- c) Description of originator's in-house waste inspection program(s) to ensure screening for hazardous and/or toxic materials or originator's written confirmation that their practices comply with uniform waste inspection program prepared by the Landfill operator.
- d) Description of volume and expected frequency of waste to be hauled and a description of the specialized waste transport vehicle(s) to be utilized.
- e) Description of the waste originator's in-house waste reduction and recycling program(s) or originator's written confirmation that their practices comply with a uniform waste reduction and recycling plan to be prepared by Landfill operator and approved by the Department of Conservation and Development.
- f) Originator's or transporter's affirmation to adhere to County imposed haul route and peak hour hauling restrictions.
- g) Written confirmation by the Landfill operator that the waste or material is not on the approved annual list described in condition 8.5, and
- h) Written waste eligibility determination from Keller Canyon Landfill Company based on a) through g) above.
- i) Requirements of Keller Canyon Landfill Company describing contract for landfill use, rules and regulations of the landfill (e.g. on-site speed limit), prescribed haul route, load inspection program, driver training program, and any other such information as required.
- j) Requirements for proper load covering or containerization and consequences for non-compliance specified in Condition 7.2.
- k) Any other information required by the Director of Conservation and Development, or by the actions of the Board on August 11, 1992, October 27, 1992, November 24, 1992, August 17, 1993 and December 14, 1993.

☆ ***New Conditions 8.5 – 8.8 do not take effect until 18 months from September 22, 2015, pursuant to the Board of Supervisors approval in conjunction with the Permit Review for Land Use Permit 2020-89.***

8.7 Direct Haul Reports. The Landfill operator shall submit quarterly direct haul reports to the Department of Conservation and Development. The quarterly reports shall contain details about all direct haul loads, including the date accepted, customer (company) name, waste type, tonnage, location and jurisdiction of waste/material origin (city and county) and end use (disposal, cover or other on-site beneficial reuse). Summarized results of all direct haul eligibility screening conducted during each period shall be submitted in conjunction with the quarterly waste origin reports. The quarterly reports shall also identify the total tonnage of municipal solid waste (Class III waste) received that quarter, total tonnage of Class II wastes received that quarter, and the percentage of total waste received which is characterized as Class II. If determined necessary by DCD, additional reporting information or more frequent reporting may be required in the future.

☆ ***New Conditions 8.5 – 8.8 do not take effect until 18 months from September 22, 2015, pursuant to the Board of Supervisors approval in conjunction with the Permit Review for Land Use Permit 2020-89.***

8.8 Emergency Direct Haul. In the event that a natural disaster or other emergency prevents the timely processing of wastes through a transfer station before disposal at the landfill, such waste or loads may be considered for direct haul. The landfill operator shall submit a written request to the County Department of Conservation and Development when circumstances or conditions warrant, or may warrant, emergency direct haul to the landfill. The landfill operator shall not proceed with emergency direct haul until written approval has been provided by the Director of the Department of Conservation and Development. The landfill operator shall submit an incident report describing the basis for emergency direct haul and the contingency actions taken.

☆ ***New Conditions 8.5 – 8.8 do not take effect until 18 months from September 22, 2015, pursuant to the Board of Supervisors approval in conjunction with the Permit Review for Land Use Permit 2020-89.***

## 9. OPERATING PARAMETERS

9.1 Hours of Operation. The Landfill operator shall not open the landfill to receive waste loads before 7:00 a.m. or after 7:00 p.m. Refuse shall be covered by 7:30 p.m. at which time working lights shall be extinguished. Entry and security lights shall be dimmed at 7:30 p.m. Other hours of operation, within those parameters, may be specified by Contra Costa Environmental Health or in the Landfill's Solid Waste Facilities Permit. Special loads may be received at other times in accordance with procedures established by Contra Costa Environmental Health or the Department of Conservation & Development.

The Director of Conservation and Development may administratively shorten

or extend the hours of operations prescribed above after consultation with the Landfill operator, Contra Costa Environmental Health, and the City of Pittsburg, after holding a public hearing to obtain the comments of other interested parties. To shorten the hours of operation, the Director of Conservation and Development shall find that the changes are needed to mitigate substantial noise, traffic, or similar impacts arising from the operation of the Landfill which were not known when this Land Use Permit was adopted. To extend the hours of operation, the Director of Conservation and Development shall find that longer hours will not cause traffic, noise, glare, or similar impacts of Landfill operations to substantially increase in the vicinity of the Landfill. Exceptions to this limitation may be granted in response to natural disasters or other emergencies if deemed warranted by the Director of Conservation and Development if required to address any applicable officially declared disaster.

- 9.2 Operating Days. The landfill shall remain open for operation six days a week except on Holidays. It shall close on Sundays. Exceptions to this limitation may be granted in response to natural disasters or other emergencies if deemed warranted by the Director of Conservation and Development.
- 9.3 Maximum Daily Tonnage. The landfill may accept for disposal a maximum of 3,500 tons of refuse per day. The Board of Supervisors shall review and revise, if necessary, the maximum allowable tonnages per day. If the Board establishes sub-County service areas, maximum tonnages for each landfill may be prorated to reflect their service areas. The Board may increase the maximum daily tonnages, if necessary, to reflect Reciprocal Capacity Agreements or emergency measures. Exceptions to this limitation may be granted in response to natural disasters or other emergencies if deemed warranted by the Director of Conservation and Development. The Landfill operator shall submit quarterly reports to the Department of Conservation and Development solely showing daily waste tonnage accepted for disposal.
- 9.4 Minimum Buffer Zone. The Landfill developer shall reserve a minimum buffer of 2,000 feet from the closest place of permanent waste placement to the closest existing residence on Jacqueline Drive.
- 9.5 Special Buffer Area. No residential housing shall be permitted at any time in the special buffer area. See Condition 23.2.
- 9.6 Dedication of Special Buffer Area. At the time of the submission of the landfill's Development and Improvement Plan, pursuant to Government Code Section 7050, the landfill owner shall offer to dedicate the fee title of the land within the Special Buffer Area to the County of Contra Costa for recordation. The County may accept the fee title and complete the

dedication subsequent to the opening of the landfill for the disposal of waste. In making the offer of dedication the Landfill owner may reserve the rights to carry out mitigation programs required by these Land Use Permit Conditions of Approval, and as may be further detailed in implementation plans required to be prepared by these Conditions within the Special Buffer Area. The Landfill operator may perform grading and make installations, such as drainage ditches within the Special Buffer Area related to the landfill facility, provided that the grading and installations are consistent with the approved final Development and Improvements Plan and do not impair the capability of the Area to accommodate agricultural grazing and provide habitat mitigation consistent with these Conditions of Approval. Similarly, the Landfill operator shall be allowed to carry out closure and post-closure activities related to the landfill or the Special Buffer Area provided that such activities are consistent with a County-approved closure plan and with the uses of the land allowed by these Conditions of Approval.

The County may require the Landfill operator to maintain the Special Buffer Area, subsequent to dedication, at the operator's expense. Maintenance shall include security, weed control, erosion control and the provision of fire trails.

## **10. WASTE MEASUREMENT AND CHARACTERIZATION**

- 10.1 Volume Estimation. The Landfill operator shall prepare reports annually estimating the remaining landfill site life (years) and capacity (cubic yards and tons). Reports shall be submitted to the Department of Conservation and Development by March 1<sup>st</sup> of each year. The Landfill operator shall also submit an initial topographic map prior to receiving wastes.
- 10.2 Scales. The Landfill developer shall install certified scale(s) at the landfill to weigh incoming and outgoing trucks. A weighing program, subject to approval by Contra Costa Environmental Health and Director of Weights and Measures, shall be implemented to monitor incoming wastes.
- 10.3 Waste Characterization. The Landfill operator shall participate with transfer station operators serving the landfill in a tracking and reporting program to characterize incoming wastes by generator (customer) name, type, amount, and originating community and perform detailed load inspections on vehicles according to a program specified by the Department of Conservation and Development. Reports shall be submitted to the Department of Conservation and Development on a quarterly basis on or before the landfill reporting deadlines specified in the Disposal Reporting regulations (Title 14).



## 11. ADMINISTRATION

- 11.1 Permit Review. The Landfill operator shall submit reports to the Department of Conservation and Development summarizing the compliance status for these Land Use Permit Conditions of Approval annually unless otherwise specified by the Director of Conservation and Development. The Board of Supervisors will hold annual public hearings to review the Conditions of Approval for this Land Use Permit for three years beginning one year after the commencement of operations of the Landfill. The Board may refer proposed changes to the Land Use Permit to the County Planning Commission for processing. Thereafter, the County Planning Commission shall hold public hearings on the Land Use Permit at three-year intervals. As a result of a review and public hearing, the County Planning Commission may recommend to the Board of Supervisors new or modified conditions to improve the public health, safety, and welfare or in response to court decisions or regulatory changes. Nothing in this condition shall preclude the Landfill owner from applying for amendments to the Land Use Permit at any time or preclude the County from addressing emergency situations or new requirements imposed by State or Federal legislation or the courts.
- 11.2 Local Advisory Committee. The Department of Conservation and Development shall organize, and the Landfill developer shall participate in a local advisory committee, consisting of elected representatives of local residents and neighborhood associations, to comment and advise on the development of the landfill and its operations. The Board of Supervisors may sanction the Local Advisory Committee as an official County committee. The committee shall be established as soon as reasonably possible after the Board of Supervisors' approval of this Land Use Permit, if such approval is forthcoming. Meetings shall be initiated following the approval of a Land Use Permit and shall be held at least quarterly through the first two years of landfill operation. Subsequently, meetings may be held annually, but with the provision for meetings on call by the chair or the written request of 3 or more members unless otherwise specified by the County Board of Supervisors. Contra Costa Environmental Health shall be notified at least 10 days in advance of all meetings. Subjects for consideration at meetings will include, but shall not be limited to safety and emergency procedures, landfill fill-related traffic problems, screening of visual impacts and problems of litter, odor, and noise control. Meeting agenda also may include discussion of reports on the landfill construction, operation and maintenance. The Landfill operator shall provide reasonable access to the landfill arranged through the Conservation and Development Department. A surcharge on the tipping fee may be used to fund the advisory group's operations.
- 11.3 Insurance and/or Bonding. The applicant shall provide the insurance and bonds specified by the units of government having approval authority over

the project. The applicant/operator is obligated to comply with additional County specified insurance and bonding requirements pursuant to Article 12 of the First Amended Landfill Franchise Agreement. Subjects may include continuity of landfill operation, non-compliance, emergency measures, construction performance, landscaping and closure.

- 11.4 Notification Program. The Landfill operator shall prepare and implement a program to notify potential customers and periodically remind existing customers of the landfill's opening and closing times, and the conditions of its use, including waste reduction and recycling requirements, load covering requirements, site access regulations, truck maintenance to conserve fuel and a detailed list of prohibited hazardous wastes and alternative disposal options. Customers shall also be notified and periodically reminded of waste acceptance eligibility criteria so that refuse loads containing materials on the list approved annually pursuant to Condition 8.5 are not being brought directly to the landfill. The program should be prepared in conjunction with the operator(s) of the transfer station(s) serving the landfill consistent with the Board of Supervisors' policies on direct haul (see Conditions 8.5 through 8.7). It shall be approved by the County Department of Conservation and Development.
- 11.5 Development Coordinator. The Landfill owner shall provide a fund to support a County Landfill Development Coordinator, if the County establishes the position, through the period of construction and landfill operations. The Coordinator shall be a staff member or a consultant. The owner shall make quarterly advance payments.

The Landfill developer and operator shall provide such information as the Development Coordinator may require to review plans and installations under the purview of the County, except that any requirements for additional studies shall be subject to the approval of the County's Director of Community Development.

- 11.6 Compliance and Mitigation Monitoring Program. The Landfill operator shall fund the County Department of Conservation and Development's program for monitoring of compliance with these Conditions of Approval and the Environmental Impact Report's mitigation monitoring program.
- 11.7 Pre-Annexation Notification. If the Landfill owner decides to request annexation of the Landfill to a city, the owner shall notify the Board of Supervisors at least 180 days in advance of filing any application for such annexation. The Board may require the Landfill owner to consult with it or County staff to determine how solid waste management programs specified in these Conditions of Approval would be carried out subsequent to annexation. In no case shall the annexation relieve the Landfill operator of

the financial responsibilities, including payment to the County of mitigation fees, specified in these Conditions.

- 11.8 Fee and Surcharge Identification. The Landfill operator (permittee) shall not identify the costs of public agency (County, etc.) fees, charges, or surcharges on bills and receipts issued to landfill users without first obtaining the specific written approval of the County.
- 11.9 Interpretation of Conditions. The Conservation and Development Department Director is authorized to interpret these Conditions in the event that any clarification is needed.
- 11.10 Conditions Requiring Franchise. Conditions of Approval 4.2, Operative Date, and 13.4, Franchise Agreement Requirement, require a franchise or agreement to be established by this County. All of the terms of said franchise or agreement shall be subordinate to these Conditions of Approval, and these Conditions of Approval shall control in the case of any conflict unless otherwise provided for pursuant to Condition 2.3. There shall be no need to amend these Conditions of Approval or the franchise in the event of such a conflict.
- 11.11 Regulations Enforced by Other Agencies. Several of these Conditions of Approval relate, paraphrase or summarize laws and regulations which are imposed and enforced by other governmental agencies which have jurisdiction over particular aspects of this project. It is this Board's intent in adopting these Conditions of Approval to provide the applicant and the public with an overview of the scope of regulation applicable to this project and to provide this County with the authority to exercise enforcement power if deemed necessary in response to violations of such laws and regulations enforced by other agencies. Unless specifically stated in the Conditions of Approval, however, it is not this Board's intent to establish rules or regulations which are stricter than the laws or regulations which are applied to this project by the other agencies with jurisdiction over aspects of this project. If another agency primarily responsible for some aspect of this project finds that any action or inaction is in compliance with, or violates, any such law or regulation, that finding shall be conclusive. If these Conditions of Approval require some approval by any other agency and that agency declines to approve or disapprove the subject matter, such approval shall be deemed to have been given for purposes of these Conditions of Approval.
- 11.12 Required Expenditures. This Board does not intend, by requiring the applicant to fund various measures, to make any decision regarding whether or not, or how, any expenditures incurred may be recovered through the rate structure or otherwise by the applicant. Any such decision by this Board shall be reserved for its consideration in the franchise or agreement. No

inference regarding this issue is to be drawn from this Board's use of any particular terminology in these Conditions of Approval.

11.13 Designation of Authority. In any instance where a Condition of Approval provides that this Board will decide or act upon a certain matter, this Board may delegate the initial decision making or action with respect to that matter to the Director of Conservation and Development or such other designee as this Board determines to be appropriate, provided that there shall be a right of appeal to this Board from any decision to the Director of Conservation and Development or other designee.

## **12. RATE REVIEW**

12.1 Rate Approval.

- a) The Board of Supervisors may at its discretion review and approve all rates charged by the landfill operator at the landfill to the extent allowed by the terms of the applicable Franchise Agreement. The rates established by the Board shall be the maximum rates.
- b) The landfill operator shall at all times maintain on file with the County, a current schedule of Base Rates and Gate Rates charged to each customer as required in Section 6.6 of the Landfill Franchise Agreement.
- c) As provided for in Condition 2.3, where there is an inconsistency between the requirement(s) of this or any other rate setting Condition in Section 12 and the terms of the Landfill Franchise Agreement which granted the operator sole discretion over setting the base gate rate charged to customers, the terms of the Landfill Franchise Agreement shall supersede the applicable language in Condition 12.1(a) and 12.2 - 12.6 until such inconsistency no longer exists pursuant to Condition 2.3(d).

12.2 Rate Review. If the Board of Supervisors elects to review and approve rates, it should be done annually in accordance with the rate review procedure established by the County. More frequent review of rates may occur if requested by the landfill operator and if the Board determines that changing circumstances warrant such review. The Board may also review rates more frequently if the Board determines that it is in the public interest to do so pursuant to the terms of the Franchise Agreement for the landfill.

12.3 Form and Content of Rate Review Application. The landfill operator shall submit its rate application in a form and content as specified by the County. The Landfill operator shall provide any relevant rate and cost information

requested by the County. Such application may require the landfill operator to submit the application on forms and/or using computer software provided by or specified by the County. The County shall have the right to inspect and audit all records of the landfill operators which support its rate review application.

- 12.4 Rate Application Guidelines. The rate application shall be designed to ensure reconciliation of rates with audited company financial statements; detailed year-to-year cost comparisons; documented guidelines for allowable expense categories, accounting methodologies, allowable management costs and other cost elements; unit usage and unit cost data on major expense items; calculation and reporting of company productivity statistics by cost category; and full documentation of assumptions and source materials. The rate application process shall also provide for comparative rate surveys with other similar operations.
- 12.5 Financial Statement. The landfill operator shall maintain full and complete accounting records in conformity with generally accepted accounting principals applied on a consistent basis. A financial statement for the proceeding fiscal year, in such form and providing such information as the Board may require, shall be submitted with each rate review application. The financial statement shall be prepared and certified by a Certified Public Accountant currently licensed to practice in the State of California. The County, through a Certified Public Accountant appointed by the County for that purpose, shall at all reasonable times have the right to inspect and audit the records of the landfill operator that supports the financial statements. The County reserves the right to determine which records are relevant.
- 12.6 Scope of Rates. The Board of Supervisors may require that the landfill operator include in its rates collection for purposes other than disposal including but not limited to, charges for funding of inspections, charges relating to origin of waste such as out-of-county waste, franchise or agreement fees, closure and postclosure maintenance of other landfills, solid waste management programs such as general litter pick-up, abandoned vehicle removal, solid waste planning, and any other conditions of approval.

### **13. FRANCHISE AGREEMENT**

- 13.1 Franchise Compliance and Agreement. The Landfill operator shall be subject to the terms and conditions of any franchise or agreement established by the Board of Supervisors. A draft franchise or agreement shall be submitted with or before the Final Development and Improvements Plan.

- 13.2 Assignment. The landfill operator and the landfill owners shall not assign or subcontract the franchise or agreement, any part of the franchise or agreement or any obligation of the franchise or agreement without written prior consent of the Board of Supervisors. Unless otherwise specified in the franchise agreement, the term "assignment" shall include any dissolution, merger, consolidation or reorganization of the landfill's ownership or the sale or other transfer of the controlling percentage of the owner's stock in the landfill or the sale of 51% of the value of the assets of the landfill's owners.
- 13.3 Contents. The franchise or agreement may contain such provisions as the Board deems necessary, including but not limited to complete indemnification of the County, liability insurance by type and amount, performance bond by type and amount, rights of the County to acquire ownership of the landfill, funding for mitigation and reimbursement of County costs, funding for closure or post-closure costs, franchise or agreement fee fees) rate review and approval procedure and determination of and consequences of breaches of the franchise.
- 13.4 Requirement. Permittee shall not establish, operate or carry on the business of a solid waste facility pursuant to this permit unless and until it has been first granted a franchise (or entered an agreement with the Board of Supervisors).
- 13.5 County Discretion. Notwithstanding any other provision of this Permit, Permittee acknowledges that the County's discretion to grant or deny one or more said exclusive, non-exclusive or otherwise franchises or similar agreements is not limited or abridged in any manner by this Permit; and that this Permit does not require the approval of any such franchise or agreement. County reserves the right as part of the negotiation and entry of any such franchise or agreement to enter a public-private partnership with the Permittee for the project and/or to pursue the rights of the County to acquire ownership of the Landfill.

#### **14. LAND USE PERMIT PLAN CONSTITUENTS**

- 14.1 Initial Development and Improvements Plan. The Initial Development and Improvements Plan approved by this Land Use Permit, and modified by these Conditions of Approval, shall consist of the following schematic plans included in the applicant's January 31, 1989 entitlement application, the Keller Canyon Landfill Comprehensive Project Description (February 1989) and addendum (December 1989), and the 3-volume Site Characterization Report (September 1989).

- a) Grading/Excavation Plans with fill limits for each phase.
- b) Layout for Groundwater Collection System.
- c) Liner System Cross-section and Installation Sequence.
- d) Leachate Collection System Layout Plan.
- e) Gas Collection Layout Plans for each phase.
- f) Surface Water Drainage Plan.
- g) Facilities Site Plan for Operations and Maintenance.
- h) Leachate, Landfill, Gas and Water Storage Facility.
- i) Landfill Access Road Plans Profiles, Typical Section.
- j) Bailey Road Plan and Typical Section.
- k) Landscape Facilities Site Plan for Operations and Maintenance.
- l) Landscape Plan for Leachate, Landfill Gas and Water Storage Facilities.
- m) Landscape Plan.

14.2 Regulatory Agency Approvals. Subsequent to the approval of this Land Use Permit, the Landfill Developer shall obtain approvals from the regulatory agencies having jurisdiction over the project, and obtain their detailed requirements for building, serving, and operating the Landfill. The approvals shall include, but are not limited to:

- a) Waste Discharge Requirements from the Regional Water Quality Control Board.
- b) Authority to Construct (and Authority to Operate Requirements) from the Bay Area Air Quality Management District.
- c) Wetland Modification Permit from the Army Corps of Engineers.
- d) Streambed Alteration Agreement from the State Department of Fish and Wildlife.

The Landfill developer shall notify the Department of Conservation and Development if proposed or adopted permit conditions or requirements of other regulatory agencies do not appear to be consistent with this Land Use Permit or the Landfill's Environmental Impact Report. The Landfill operator shall submit to the County copies of all new and modified permits or entitlements at the time each is issued or approved by the applicable regulatory agency.

14.3 Improvements Requirements. Subsequent to the approval of this Land Use Permit, the Landfill developer shall obtain approvals from the agencies, utilities, and parties having jurisdiction or control over the on-site and off-site improvements required by this Land Use Permit or by agencies having regulatory jurisdiction over the project. The Landfill developer shall notify the Conservation and Development Department if proposed or adopted Conditions or requirements do not appear to be consistent with this Land Use

Permit or the Landfill's Environmental Impact Report.

## 15. DEVELOPMENT AND IMPROVEMENTS PLAN

15.1 Final Development and Improvements Plan. Subsequent to the approval of the Land Use Permit but prior to the commencement of any construction, the Landfill developer shall submit a Development and Improvements Plan to the Conservation and Development Department and obtain the approval of the Director of Community Development. The Development and Improvements Plan shall be consistent with the project approved by the Land Use Permit, but prepared to a level of detail appropriate for the review of the engineering and construction of the project's on-site and off-site improvements. It shall be internally consistent with the project's Environmental Impact Report findings, these Conditions of Approval, regulatory agencies and others having discretionary approvals over the project, and the Solid Waste Facilities Permit issued by Contra Costa Environmental Health. The Conservation and Development Department will coordinate the review of the plan by Contra Costa Environmental Health, the Public Works Department, and other appropriate units of government. The Landfill developer shall comply with all provisions of the final Developments and Improvements Plan.

The Development and Improvements Plan shall include:

- a) Site Development Plan, as described in the following sections.
- b) A Surface Water Management and Sediment Control Plan, (Section 18).
- c) An Agricultural and Habitat Enhancement Plan, (Section 23).
- d) A Waste Reduction and Resource Recovery Program, (Section 31).
- e) A Landscape (screening) Plan, (Section 22).
- f) A Landfill Gas Management/Air Quality Monitoring/Odor Control Plan, (Section 20).
- g) A Leachate Management Plan, (Section 17).
- h) A Site Services and Utilities Plan (Section 30).
- i) A Traffic/Circulation Plan, (Section 29).

15.2 In approving the Development and Improvements Plan, the Conservation and Development Department Director may allow the Landfill developer to phase construction of landfill modules and other features, except where timing is specified in these conditions. The submittal of the Development and Improvements Plan components may reflect this phasing.



## **16. SLOPE AND SEISMIC STABILITY**

- 16.1 Landfill Slopes Objective. Landfill slopes shall be engineered to provide static and dynamic (seismic) stability under design criteria for Class II Landfills.
- 16.2 Seismic Design. The Landfill, its drainage features and operating components (lifts, berms, liners, sediment pond, leachate and gas collection systems and major stockpiles) shall be designed to withstand earthquakes as specified in applicable regulations. The Landfill developer shall utilize a MCE (design earthquake) specified by the San Francisco Regional Water Quality Control Board. The Landfill developer shall provide substantiation in the Final Development and Improvements Plan that the Landfill design will withstand the MCE.
- 16.3 Landslide Study. The Landfill developer shall employ a licensed geotechnical consultant to conduct a supplementary study of landslides and slope stability in areas of the site affected by Landfill and improvements grading. The study shall be performed by a licensed geotechnical professional. The study shall be subject to the approval of the County and the San Francisco Regional Water Quality Control Board. The Landfill developer shall incorporate the results of the study into the site grading program and the designs of overlying structures, which shall be included in the Development and Improvements Plan.
- 16.4 Geotechnical Inspector. The Landfill operator shall fund the costs of an independent geotechnical consultant, who shall be selected by and be responsible to the County. The Inspector shall inspect the installation and condition of liners, leachate control facilities and other installations, identified by the County, as they are installed and periodically thereafter as directed by the County. This provision shall remain in force over the life of the landfill.
- 16.5 Landfill Design Stability. The Landfill developer shall provide a static and dynamic stability analysis of the final engineering design of the Landfill and its appurtenant improvements. The stability analysis method and the resulting analysis shall be approved by the County Conservation and Development Department and the San Francisco Regional Water Quality Control Board and included in the Final Development and Improvements Plan.
- 16.6 Slope Monitoring. The Landfill operator shall install and maintain slope monitoring stakes on landslides and sensitive slopes which could affect an operating Landfill. The monitoring program shall be approved by the County Department of Conservation and Development.

- 16.7 Settlement Program. The Landfill developer shall implement a program to prevent fill settlement and an inspection program to detect and correct settlement problems. The developer shall compact the refuse and cover materials to maximum strength and design and maintain the necessary slope gradient to ensure proper surface water drainage. A network of settlement platforms shall be installed to monitor fill settlement at critical points. The station specifications and locations shall be included in the Improvements and Development Plan. The Settlement program shall be subject to the approval of the County Conservation and Development Department and the San Francisco Regional Water Quality Control Board.
- 16.8 Emergency Landslide and Earthquake Program. The Landfill operator shall prepare and implement an emergency program for inspecting the Landfill facility, dealing with failures and providing for uninterrupted refuse handling for implementation following a landslide and/or earthquake. The program shall be subject to the approval of the County Department of Conservation and Development, Contra Costa Environmental Health and the Regional Water Quality Control Board.
- 16.9 Settlement Pond Embankment Design. The Landfill developer shall design the settlement pond to control foundation seepage through the means of a filter or other materials.
- 16.10 Settlement Pond(s) Monitoring Program. The Landfill operator shall prepare and implement a failure prevention and warning system, including daily monitoring and visual inspection, for the sedimentation ponds. The program shall be approved by the County Conservation and Development Department and shall be included in the Development and Improvements Plan.
- 16.11 Stockpile Stability. Commencing with the onset of stockpiling, the Landfill operator shall continually analyze daily cover material stockpiles for stability to determine allowable heights and/or slopes. The results shall be available to the County Conservation and Development Department and Contra Costa Environmental Health on demand.
- 16.12 Unstable Areas. Areas with landslide potential to affect landfill operations shall be stabilized through excavation or other methods such as compacting or the construction of retaining walls. Grading operations shall be performed in a manner which shall not destabilize slopes.

## **17. GROUNDWATER PROTECTION**

- 17.1 Groundwater Protection Objective. The Landfill shall not impair the

beneficial uses of groundwater on the Landfill site or in its vicinity. The design and monitoring of the Landfill shall be based upon the assumption of the existence of high permeability interconnecting cracks and fissures in the underlying strata allowing the potential of groundwater transmission.

- 17.2 Landfill Liner. The Landfill developer shall install a engineered liner system, including a clay liner and a high-density polyethylene liner, which meets State Class II Landfill standards. The liner shall be approved by the San Francisco Bay Regional Water Quality Control Board and its specifications and design shall be included in the Development and Improvements Plan. The liner shall be designed to withstand the Maximum Credible Earthquake as specified by the Regional Water quality Control Board. See Section 16.
- 17.3 Leachate Collection System. The Landfill developer shall install a leachate collection system which shall meet State Class II standards. The leachate collection system shall be approved by the San Francisco Bay Regional Water Quality Control Board, and its specifications and design shall be included in the Development and Improvements Plan. Leachate shall be contained by a double liner system consisting of a two-foot thick layer of clay overlain by a synthetic membrane liner. Enclosed storage tank design for leachate treatment shall meet hazardous waste storage requirements, which includes a double liner system with perimeter berms. An emergency connector shall be installed between the pre- and post-treatment tanks in the event of an overflow situation. A tanker truck shall be readily available for emergency purposes. Measures shall be taken to limit leachate formation, such as prompt covering of waste and provision of surface water drainage away from landfill areas.
- 17.4 Surface Drainage System. Water collected in the underdrain system beneath the landfill shall be monitored on a regular basis specified by the San Francisco Regional Water Quality Control Board. If contaminated, this water shall be treated as leachate. See Section 18.2.
- 17.5 Groundwater Monitoring. The Landfill developer shall install a groundwater monitoring system and implement a monitoring program, as required by the San Francisco Bay Regional Water Quality Control Board. The monitoring stations' specifications, locations, and their frequency of monitoring shall be included in the Development and Improvements Plan. The proposed monitoring program shall be subject to review by Contra Costa Environmental Health and the County Conservation and Development Department.
- 17.6 Downstream Well Monitoring. . The groundwater monitoring program shall include selected wells down gradient from the site. The wells shall be subject to approval by the San Francisco Regional Water Quality Control

Board. The Landfill operator shall sample and analyze water from these wells as required by the Regional Water Quality Control Board. The location of these wells shall be identified on the Development and Improvements Plan.

- 17.7 Baseline Water Characterization. The Landfill developer shall conduct a groundwater characterization study for at least a one-year period following the approval of the Land Use Permit. The procedures for the study shall be specified by the San Francisco Bay Water Quality Control Board and Contra Costa Environmental Health.
- 17.8 Liquid Waste Disposal. The Landfill operator shall comply with the requirements of the Regional Water Quality Control Board for disposal of de-watered sewage and other utilities' sludges in the Landfill to prevent excess liquid concentrations. The Landfill operator shall not accept other liquid wastes.
- 17.9 Drainage Grading. The Landfill developer shall grade completed fill areas to convey surface run-off to ditches at the fill perimeter to limit infiltration into the Landfill. The grading specifications shall be included in the Development and Improvements Plan.
- 17.10 Leachate Management. The Landfill operator may reapply leachate removed from the leachate collection sumps to the Landfill for absorption by solid waste, or arrange for its transportation (pretreated if necessary) to an appropriate treatment and disposal facility. If leachate is returned to the fill area, it shall be injected under the Landfill's cover rather than applied over its surface. The return of leachate to the Landfill shall be subject to the solids-to-liquids ratio restrictions defined by the San Francisco Bay Regional Water Quality Control Board and Contra Costa Environmental Health. If leachate is transported to an off-site disposal/treatment facility, it shall be pretreated on-site to meet all requirements of such facility before transport. If leachate build up becomes a problem, Contra Costa Environmental Health may require additional remedial measures, such as the placement of more soil cover, or the installment of a low-permeability earthen or synthetic cover. The Leachate Management Program shall be included as part of the Site Design Plan.
- 17.11 Water Balance Calculations. The Landfill operator shall provide water balance calculations, when requested by the Regional Water Quality Control Board or other applicable regulatory agency, to evaluate intermediate stages of Landfill operation to ensure the maintenance of a proper solids-to-liquid ratio.
- 17.12 Leachate Holding Tanks. Holding tanks for leachate shall be tested to

ensure chemical compatibility to prevent chemical degradation of said tanks. The Landfill developer shall submit test results to the Regional Water Quality Control Board and Contra Costa Environmental Health, prior to the submission of the Development and Improvements Plan.

- 17.13 On-Site Water Supply Wells. The Landfill developer shall construct the proposed on-site water supply wells after a hydro-geologic investigation has determined flow direction and relationship between water bearing strata if any. Water supply wells shall utilize separate water bearing strata, and shall be sealed to prevent communication between shallow and deep ground water. The locations and characteristics of water supply wells shall be described in the Development and Improvements Plan, and shall be subject to Contra Costa Environmental Health and San Francisco Regional Water Quality Control Board approval. Pump tests shall be provided for on-site wells located within 500 feet of any domestic well to evaluate interference between wells.
- 17.14 Off-Site Water Well Contamination. If the water quality of nearby domestic water supplies is impaired by Landfill leachate, the Landfill operator shall take immediate remedial action that is acceptable to Contra Costa Environmental Health and the San Francisco Regional Water Quality Control Board. The source of contamination shall be identified and immediately repaired. Remedial measures shall include but are not limited to extraction wells and slurry walls. The Landfill operator may be required to replace the impaired water supply.
- 17.15 Liner Installation Inspection. See Condition 16.4.
- 17.16 Secondary Containment. The Landfill developer shall construct a secondary containment system capable of containing 1.5 times the volume of each leachate-holding tank.
- 17.17 Working Face. The Landfill operator shall maintain a maximum daily working face of 3 acres or less in order to minimize surface water infiltration to the refuse, as well as to control dust and erosion, prevent vector proliferation, and minimize visual impacts. Exceptions to this limitation may be granted in response to natural disasters or other emergencies if deemed to be warranted by the Director of Conservation and Development.

## **18. SURFACE WATER PROTECTION**

- 18.1 Surface Water Protection Objective. The Landfill shall not impair the beneficial uses of water bodies in the vicinity of the Landfill site.

- 18.2 Surface Drainage System. The Landfill operator shall install and maintain a Landfill surface drainage system which shall be designed to meet State Class II standards. It shall accommodate a 1,000-year, 24-hour design storm, as specified by the County Public Works Department and the San Francisco Regional Water Quality Control Board (SFRWQCB). The drainage system shall convey surface water around the active fill area without contacting the working face or any solid waste. The surface drainage system shall be approved by the SFRWQCB and the County Department of Conservation and Development and included in the Development and Improvements Plan. Surface flow shall be evaluated further with groundwater levels and precipitation factors prior to construction, and findings incorporated into the final landfill design in order to lessen impacts to surface water flow. Flow rates and groundwater levels shall be monitored through the life of the landfill. If loss of surface flow is determined to have unforeseen impacts, a like amount of water shall be provided.
- 18.3 Creek Protection. The landfill shall be designed so leachate and other contaminated water does not flow into Lawlor Creek. See Section 23.3.
- 18.4 Surface Water Management and Sediment Control Plan. The Landfill developer shall prepare and implement a Surface Water Management and Sediment Control Plan, which shall be subject to the approval of the County Department of Conservation and Development. The plan shall include a Stability Analysis of proposed cut and fill slopes, and shall prevent substantial erosion on slopes on the project site and reduce the amounts of water-borne materials from reaching surface waters. It shall include the components listed below, and it shall be included in the Final Improvements and Development Plan.
- a) Primary Grading. The Landfill developer shall perform primary grading for the project's fill modules, cover, roads, paved areas, building sites, and the construction of site slopes during the April through October low rainfall season.
  - b) Temporary Flow Restriction. If grading must be done during rainy periods, or if erosion is occurring on previously graded areas, the Landfill developer shall take corrective actions, which may include the installation of ground cloth or the placement of hay bales.
  - c) Ground Cover. The Landfill developer shall plant ground cover on graded areas which are not to be developed within 90 days. The ground cover shall be consistent with the Landscaping Plan.
  - d) Ditch/Swale Liners. The Landfill developer shall line any ditches and swales for conveying surface runoff across sanitary Landfill areas to limit water infiltration. Drainage-ways across other areas shall be lined or planted to limit erosion.

- e) Sedimentation Ponds. The Landfill developer shall install and maintain a sedimentation pond system prior to other landfill development to hold and process drainage from the Landfill property which shall be designed to withstand the 1,000-year, 24-hour design storm and Maximum Credible Earthquake event. The Landfill developer shall develop a program for monitoring storage volumes in the sedimentation ponds and releasing water depending on expected rainfall. Flow rates for downstream discharge shall not exceed the 25-year, 24-hour design storm. The program shall include a preventive maintenance program which shall include a program for clearing of sedimentation ponds and maintenance of perimeter ditches and vegetative cover. The owner shall submit documentation to the Department of Conservation and Development to demonstrate that basin maintenance (e.g. dredging) has been completed as needed or required prior to the start of the rainy season (October 15<sup>th</sup>). The program shall be subject to approval from the County Department of Conservation and Development, Contra Costa Environmental Health, Public Works Department, and the San Francisco Regional Water Quality Control Board. The efficacy of the Landfill surface water control system in reducing downstream flooding shall be addressed in the annual and triennial reviews required by Condition 11.1.
- f) Runoff Conveyance. Erosion to ditches or gullies used to convey runoff shall be corrected by use of appropriate measures such as energy dissipators or rip rap.
- g) Equalization Basin. Water in contact with the working face area of the landfill shall be discharged into an equalization basin, monitored, and treated if necessary.

18.5 Monitoring. The Landfill developer shall prepare and implement a surface water monitoring program to check for possible contamination of off-site surface water drainage facilities. Baseline water quality shall be determined prior to project implementation. Sedimentation pond outflow shall be monitored. The monitoring program shall be subject to approval of Contra Costa Environmental Health, the County Conservation and Development Department, and the Regional Water Quality Control Board.

## **19. HAZARDOUS WASTE**

19.1 Hazardous Waste Ineligible. See Section 6.4.

19.2 Load Inspection. See Condition 7.1

- 19.3 Household Hazardous Waste Program. The Landfill operator shall develop a household hazardous waste collection and management program for the service area which is consistent with the County Hazardous Waste Management Plan and with the County Integrated Solid Waste Management Plan. The program shall be subject to the approval of the Contra Costa Environmental Health and Conservation and Development Departments. The household hazardous waste shall be managed in accordance with the "Waste Minimization Hierarchy" identified in the County Hazardous Waste Management Plan. The operator is encouraged to develop the program in cooperation with other waste management facilities and collection services. The proposed program, along with a schedule of proposed costs and funding sources, shall be submitted to the County departments no later than 6 months prior to the opening of the landfill. The program shall include mechanisms for removing household hazardous waste from the waste stream which arrives at the facility. If the household hazardous waste program (or a version of it) is approved by the County Board of Supervisors, the Landfill operator shall implement it. The Landfill household hazardous waste program shall include a public information and education program approved by the County Health Services Department/County Hazardous Materials Commission for notifying facility users and households in its service area of what constitutes hazardous waste and how such wastes are to be disposed of. The household hazardous waste program shall be amended if required by the County Board of Supervisors in their review of the Land Use Permit.
- 19.4 Hazardous Waste Pre-screening. The landfill entrance load screening procedures and a manual load check program during unloading operations shall be included in the load screening program required under Condition 7.1. Landfill employees shall be instructed to investigate suspicious containers for hazardous materials during bulldozing and other activities. Any hazardous materials found shall be set aside for proper collection and disposal.
- 19.5 Regulatory Agency Approvals. The collection and storage of toxic and hazardous wastes pursuant to this section shall be subject to County Health Services Department's Hazardous Materials Division, State Department of Health Services, and other regulatory agency approvals.

## **20. AIR QUALITY PROTECTION**

- 20.1 Prevention of Air Quality Deterioration. The Landfill operator shall manage the facility in a manner that does not result in the significant deterioration of air quality in the vicinity of the site or in the Bay Area. The condition shall be interpreted as a requirement that the Landfill comply with terms of the



Authority to Construct Permit to Operate permits issued by the Bay Area Air Quality Management District.

- 20.2 Odor Containment. The Landfill operator shall operate the Landfill in a manner that prevents odors from being detected off-site, pursuant to Regulations 7-101 and 7-102 of the Bay Area Air Quality Management District. If odors are reported to Contra Costa Environmental Health, or reports are relayed from the Bay Area Air Quality Management District, the Department of Conservation and Development or Contra Costa Environmental Health may require additional physical improvements or management practices as necessary to alleviate the problem. Contra Costa Environmental Health shall have the authority to cease disposal at a particular area of the Landfill, to control odors. A small daily working face (3 acres or less) shall be maintained. The leachate treatment system shall be enclosed and properly maintained to control odors from leachate. The landfill gas collection system and flare shall utilize BACT to reduce landfill gas as a source of toxics and odor.

The Landfill operator shall implement Best Management Practices of the industry to minimize odors from operations and emissions from equipment. If the operator is contacted about odors being detected off-site, the date, time and description of the odor complaint shall be logged and investigated promptly to expedite implementation of any necessary corrective action by the landfill operator. The Landfill operator shall contact Contra Costa Environmental Health or the Bay Area Air Quality Management District at minimum of once per year to obtain any information possible about odor complaints received by each agency. Any odor complaints received by the Landfill operator, Contra Costa Environmental Health or the Bay Area Air Quality Management District shall be included in the annual Activities Report required under the Landfill's Franchise Agreement unless otherwise specified by the Director of Conservation and Development. The landfill operator shall provide a means for receiving after hours odor complaints. Complaints shall be promptly investigated (after hours investigations required if/when multiple after hours complaints received on the same day or on multiple consecutive days) to identify whether the source of the odor is on the landfill site, in which case the problem should be corrected in a timely manner. A response to the person lodging the complaint shall be made within 48 hours and copied to the Department of Conservation and Development, detailing the problem and remedial action taken.

- 20.3 Cover Frequency. The Landfill operator shall cover newly disposed refuse with compacted soil or other cover material meeting state regulatory requirements enforced by Contra Costa Environmental Health and CalRecycle and approved in writing by the Department of Conservation and Development.

All working faces of the Landfill shall be covered by the end of the working day. Intermediate cover, meeting the requirements of the State shall be applied over each layer of cells ("lift"). The type of cover material and frequency of cover shall be modified in order to control odor, litter or birds, if necessary, or if required by the Director of Conservation and Development or the Landfill's Solid Waste Facilities Permit.

- 20.4 Odoriferous Loads. The Landfill operator shall identify potentially odoriferous loads prior to acceptance and make any arrangements needed to ensure that disposal of odoriferous loads is managed to avoid off-site detection, which may involve covering such incoming loads immediately.
- 20.5 Dust Suppressants. The Landfill operator shall apply water or proven environmentally safe dust suppressants at least twice daily to working faces of the landfill, unpaved access roads, storage pile disturbances and construction areas as determined to be necessary by Contra Costa Environmental Health. Contra Costa Environmental Health may require sprinklering more frequently for control of particulates.
- 20.6 Area of Operations. See Conditions 17.17 and 22.10.
- 20.7 Air Flow Monitoring. The Landfill operator shall monitor air flow on the site upon commencement of operations and shall provide background meteorological conditions including wind direction, wind velocity, and temperature. After the Landfill is in operation, data shall be used to correlate odor, dust, or litter management with meteorological conditions. Air flow monitoring reports shall be submitted or made available to the Contra Costa Environmental Health and the Department of Conservation and Development upon request.
- 20.8 Contingency Program. Prior to the start of filling operations, Landfill operator shall prepare a "bad days" contingency program for managing the Landfill during periods of unusual wind speeds or directions, rainfall or drought or other atypical situations. It shall apply specific site monitoring information. The Landfill operator shall consider the comments of the City of Pittsburg and consult with the Bay Area Air Quality Management District and the Regional Water Quality Control Board. The program shall be approved by the Department of Conservation and Development and Contra Costa Environmental Health, and it may be revised from time to time. See Condition 25.4.
- 20.9 Revegetation. The Landfill operator shall revegetate completed Landfill areas. Revegetation shall be in accordance with the Development and Improvements Plan and shall be consistent with State and local water conservation landscaping requirements. Intermediate and final cover areas

shall be reseeded with native grasses immediately. Excavations shall be reseeded with native grasses or filled immediately. Operating areas which will not be used for fill or construction for 90 days or longer shall be planted for dust and erosion control and for aesthetic purposes. Landfill operator shall provide the County Conservation and Development Department with written notice and documentation (e.g. photographs) of any inactive unvegetated areas of disturbance not being reseeded immediately whether due to on-site activity associated with the landfill (construction or operations) or naturally occurring (landslides, etc.). The Director of Conservation and Development may require that revegetation notices be submitted more frequently and/or on a fixed schedule.

- 20.10 Tree and Shrub Planting. The Landfill developer shall plant trees and shrubs downwind of the Landfill to aid in trapping dust. The planting plan shall be included in the Landscaping plan component of the Development and Improvements Plan.
- 20.11 Gas Control and Collection. The Landfill operator shall install a Landfill gas control collection system in accordance with the regulations of the Bay Area Air Quality Management District. The system shall have the capacity to operate in an active mode, using a mechanical vacuum, to withdraw gas from the Landfill. The system shall be operated in an active mode as soon as practical. The gas control and collection system shall be installed concurrently with the placement of wastes in the Landfill and shall be ready for operation when gas is produced. The gas collection and related recovery system shall utilize BACT and shall be subject to the approval of the Bay Air Quality Management District and County Conservation and Development Department and it shall be included in the Development and Improvements Plan.
- 20.12 Landfill Gas Processing. The Landfill developer shall install a flaring mechanism, in accordance with Bay Area Air Quality Management District guidelines/regulations, to combust collected landfill gas. The flare shall be of the nonilluminous type. Best Available Control Technology (BACT) shall be used, as defined and approved by the Bay Area Air Quality Management District. The flare shall be installed with staged combustion, operated under fuel-rich conditions, and be designed with flue gas recirculation.
- 20.13 Methane Recovery. The Landfill operator shall install a methane recovery system simultaneously with the construction of the gas collection system, preferably utilizing the Landfill gas to produce energy when the Landfill has developed enough gas to justify recovery. When required by the County Conservation and Development Department, the Landfill operator shall conduct a study to determine how methane could be recovered from the gas and used for fuel or as a commodity.

- 20.14 Gas Monitoring. The Landfill developer shall install gas migration detection probes and wells along the boundary of the Landfill footprint, near on-site buildings, and in other locations specified by the Bay Area Air Quality Management District or Contra Costa Environmental Health to monitor for subsurface and surface gas migration. The gas monitoring stations shall be described in the Development and Improvements Plan approved by the County Conservation and Development Department. If gas migration is found, the Landfill operator shall notify the County and take remedial actions. Training of employees for detection of gas migration shall be included in the employee training program.
- 20.15 Lateral Gas Barriers. The Landfill developer shall install a gas barrier or gas collection area on side slopes of the Landfill to prevent lateral gas migration through the sides of the Landfill. The barrier or gas collection area shall be approved by the Bay Area Air Quality Management District and shall be included in the Development and Improvements Plan.
- 20.16 Settlement Protection. The Landfill developer shall use flexible piping and lightweight backfill for the Landfill gas collection system to ensure that settlement of the fill will not affect operation of the system.
- 20.17 Landfill Gas Testing. The Landfill operator shall test Landfill gas for its toxic composition and for toxic constituents. The testing program shall be subject to the approvals of the Bay Area Air Quality Management District, Contra Costa Environmental Health and the Department of Conservation and Development. The Landfill operator shall provide the results to the County Department of Conservation and Development and Contra Costa Environmental Health on a bi-annual basis unless a more frequent interval is specified in the Solid Waste Facilities Permit.
- 20.18 Leachate Disposal. See Condition 17.10.
- 20.19 Cell Re-Opening. Previously-closed cells shall not be reopened without permission from Contra Costa Environmental Health. The Department of Conservation and Development shall be notified of any occurrence that potentially necessitates that one or more cells be re-opened.
- 20.20 Fissure Repair. The Landfill operator shall inspect the Landfill daily. Surface cracks, fissures, eroded areas, or inadequately covered areas on the Landfill may require repairs within 24 hours. The Department of Conservation and Development shall be notified in writing at the time the operator identifies any substantial surface cracks or fissures requiring repairs beyond the placement and compaction of additional clean soil. Photo of the crack should accompany the written notice which describes he

expected cause and corrective action plans and repair schedule. This activity shall be included in the employee training program.

- 20.21 Permanent Road Paving. The Landfill developer shall pave and maintain permanent access roads to control dust. A road used for one year or longer shall be considered to be a permanent road. Road construction shall be described in the Development and Improvements Plan.
- 20.22 Temporary Road Paving. The Landfill developer shall pave and maintain temporary road with gravel or crushed aggregate. Temporary roads shall be wetted or chemically treated when necessary to control dust. Road construction shall be described in the Development and Improvements Plan.
- 20.23 Speed Limits. The Landfill operator shall enforce speed limits set by the Contra Costa Environmental Health on internal site roads. The Landfill operator shall install appropriate signs and speed control devices. The maximum internal on-site speed limit shall be 20 mph unless otherwise specified by Contra Costa Environmental Health.
- 20.24 Equipment Maintenance. The Landfill operator shall maintain Landfill equipment in optimum working order to ensure that vehicle emissions are controlled and equipment shall be fitted with spark arrestors so potential for causing fires is minimized. Equipment shall not be left idling when not in use. Maintenance records shall be kept on all pieces of Landfill equipment. The records are subject to review by Contra Costa Environmental Health. Equipment shall be stored, serviced, and repaired in a maintenance area designated in the Development and Improvements Plan and approved by the County Conservation and Development Department.

## **21. NOISE CONTROL**

- 21.1 Noise Control Objective. The Landfill operator shall manage the facility in a manner that minimizes noise impacts to area residents.
- 21.2 Noise Monitoring Program. The Landfill operator shall prepare and implement a noise monitoring and abatement program, which shall be approved by the County Department of Conservation and Development and Contra Costa Environmental Health. The program shall monitor noise levels at sensitive receptor locations, one West of Bailey Road and South of West Leland Road, one near Bailey north of West Leland, and another in the Jacqueline Drive area south of West Leland Road. The Director of Conservation and Development may specify other monitoring locations. Noise monitoring reports shall be submitted to the County Conservation and Development Department on a quarterly basis unless otherwise specified by

the Director of Conservation and Development. If the monitoring noise levels at the Landfill boundary line or other monitored location exceed 60 dBA during daylight hours, or 50 dBA during the evening or at night, the County may require the operator to institute additional noise reduction measures to bring noise emanating from the Landfill to the forementioned levels or less.

- 21.3 Toe Berm. See Condition 22.3.
- 21.4 Mitigation/Lift-Level Berms. See Condition 22.4
- 21.5 Construction Hours. See Condition 32.1.
- 21.6 Truck Noise Suppression. The Landfill operator shall require transfer trucks and other waste hauling vehicles using the facility to be equipped with factory approved noise suppression equipment, including engine compartment insulation. The Landfill operator shall request the California Highway Patrol actively enforce muffler and vehicle noise standards as required in the California Vehicle Code if, for any reason, noise from heavy trucks becomes a source of complaints in the project area, whether project-related or not. Transfer trucks and other waste hauling vehicles with faulty mufflers shall be denied access to the landfill after one warning by a landfill operator at the landfill entrance.
- 21.7 Landfill Vehicles. The Landfill operator shall provide Landfill equipment with the best available noise suppressing equipment to minimize sound generation.
- 21.8 Gas Flare Muffling. If flaring is used to dispose of Landfill gas, the flares shall be contained in noise and glare-reducing housing. The housing shall be subject to the approval of the Contra Costa Environmental Health and Conservation and Development Departments and the Bay Area Air Quality Management District.

## **22. VISUAL QUALITY**

- 22.1 Visual Quality Objective. The Landfill developer shall construct and operate the facility in such a manner that the high visual value of the surrounding area is maintained.
- 22.2 Landscape Plan. The Landfill developer shall prepare and implement a site Landscaping Plan. The plan shall enhance the site's visual values as open space and its functional values as wildlife habitat. It shall minimize the visual impacts of the landfill operations and appurtenant facilities through revegetation and landscape screening. The plan shall show the plant

species, size, and locations to be used to blend in with the existing natural vegetation. Natural, drought tolerant species shall be used, in accordance with State and local water conservation landscaping requirements. A landscape maintenance program shall be part of the plan. A Weed Monitoring and Control Program shall be included, containing a listing of noxious weeds, a monitoring program, and abatement measure options. A Landscape Plan shall be included in the Development and Improvements Plan. The Landscape Plan shall assure no visual impact on the Cities of Concord and Clayton consistent with the Environmental Impact Report.

- 22.3 Toe Berm. The Landfill developer shall install the first phase of the toe berm prior to other landfill construction and development of the Landfill. Other sections of the toe berm shall be installed in stages (see condition 32.4). The toe berm shall be contoured to blend with existing topography. It shall be designed to screen the landfill access road. It shall be revegetated immediately with native grasses and other vegetation to blend in with the surrounding area.
- 22.4 Mitigation Berms. The Landfill developer shall install landscaped mitigation berms (lift-level peripheral berms) at the face of each lift in areas visible off the Landfill site, before beginning refuse disposal on the lift. The berms shall be landscaped to blend with existing terrain. Specific heights for the initial toe berm and each of its phases shall be established in the Final Development and Improvements Plan (Condition 15.1).
- 22.5 Lawlor Creek Corridor Plan. See Condition 23.3.
- 22.6 Entrance Screening. The Landfill developer shall install landscaping at the entrance of the landfill to screen the entrance facilities from Bailey Road users. Olive trees shall not be included as part of the entrance landscape plan.
- 22.7 Jacqueline Drive Terminus. The north terminus of Jacqueline Drive shall be landscaped, with native species, to shield near-views of the toe berm. Planting of the terminus area shall begin as soon as practicable. The outside access road berm shall be a minimum of 15 feet high to shield transfer truck traffic and noise from nearby residences.
- 22.8 Auxiliary Facilities Screening. The landscaping plan shall provide for the screening of auxiliary areas, such as the administrative buildings, parking lots, maintenance facilities, and screening of facilities shall occur during the first year of development. Enhancement of Lawlor Creek shall occur during the first year, to aid in screening facilities from Bailey Road users.
- 22.9 Architectural Treatment. Plans for buildings and other structures shall

include architectural sections showing design and materials to be used. Buildings shall be designed to blend into the rural agricultural setting.

- 22.10 Area of Operations. Except during construction of modules and other major installations, the Landfill operator shall limit unvegetated working areas of the landfill, including the daily working face, to 25 acres for appearance and to control dust and erosion. The restriction shall not apply to grading for foundations, cover, site roads, berms and other construction, providing these are carried out expeditiously.
- 22.11 Interim Revegetation. Interim revegetation shall be required on all areas that will be inactive for more than 90 days. Revegetation shall include native grasses, shrubs and trees to lend more variety and natural appearance to the finished landfill.
- 22.12 Water Tank Screening. The Landfill developer shall provide landscaping to screen the facility's water tanks. Where possible, the landscaping shall be installed prior to the installation of the tank. Consideration shall be given to subsurface or partially buried tanks, and to painting the structures with earth-tone colors.
- 22.13 Final Cover. Final cover shall be contoured and landscaped to blend with existing topography.
- 22.14 Lighting. The Landfill developer shall design and locate the lighting system to reduce glare and reduce impact to area residents. Focused directional security and operational lighting shall be installed. Operation lighting on the working face shall be turned off by 7:30 p.m. Security and entrance lighting shall be dimmed at 7:30 p.m.

## **23. AGRICULTURAL AND BIOTIC RESOURCES**

### **23.1 Biotics Protection Objectives.**

- a) The Landfill developer shall construct and operate the facility in such a manner that ensures, through protection and enhancement measures, that there is no net loss of significant habitat, wetland, woodland, or agricultural production.
- b) The Landfill developer shall provide at least twice the amount of mitigation wetland for significant wetland lost to the project (2-to-1 mitigation). A minimum of six acres of mitigation wetland shall be provided. Wetland loss shall be mitigated through the enhancement of stock ponds and sedimentation basins, or the creation of new



wetlands.

- 23.2 Range Management Plan. The Landfill operator shall design and develop a Range Management Plan in order to provide for continued grazing on portions of the site. The Special Buffer Area shall remain as Agricultural Preserve, and development rights shall be conveyed to the County. The buffer area and other site rangelands of the Primary Project Area not exempted for habitat protection and not in active landfill use shall be enhanced as grassland/oak woodland, and shall provide grazing for at least 270 head of cattle, approximately the same number of cattle which presently graze on the site. Stock watering ponds shall be enhanced through planting of trees and shrubs. Grazing shall be restricted for a 1 to 2 year period in order for grasses to get reestablished. It shall provide for adequate grazing range, and for native tree species such as oaks to be planted for animal protection and to replace trees removed during landfill construction, while controlling soil erosion. The plan shall be prepared in consultation with the Contra Costa County Resource Conservation District and the Agricultural Extension Service. It shall be coordinated with the Landscape Plan, the Habitat Preservation Plan, and the Erosion and Sediment Control Plan developed for the landfill facility. It shall be subject to the approval of the County Conservation and Development Department and it shall be included in the Improvements and Development Plan.
- 23.3 Lawlor Creek Corridor Restoration Plan. Enhancement of this riparian area shall replace habitat lost by the rerouting and covering of a portion of the unnamed drainageway within the waste placement area. This plan shall provide replacement for habitat lost to landfill construction. The Corridor Plan shall also provide screening of the landfill entrance and service facilities from Bailey Road. Livestock fencing shall be constructed around the perimeter of approximately 35 acres to exclude cattle from the riparian and oak woodland areas. Litter shall be removed from the creek and corridor, and fencing shall be established along Bailey Road to prevent unlawful disposal of trash. Riparian species of trees such as Willows, Fremont cottonwood, sycamore and other oak species, California Bay Laurel and shrubs shall be planted. The access road crossing of Lawlor Creek shall be designed and constructed in a manner that would be compatible with the aesthetics of the corridor and habitat enhancement. Installation of horizontal drainage pipes into hillsides may be provided to tap groundwater sources to improve creek flow conditions. A monitoring and maintenance program shall be established to insure wildlife habitat values are protected. Rock dams, overhangs, splash pools and erosion control structures shall be included in the corridor plan design. The detailed restoration plan shall be developed for Lawlor Creek in coordination with the County, the California Department of Fish and Wildlife, U.S. Fish and Wildlife Service, local Audubon and California Native Plant Society representatives and other environmental

organizations. A streambed alteration agreement shall be obtained if determined to be necessary by the CDF&G. A wetland modification permit shall be obtained from the Army Corps of Engineers if necessary. Implementation of the Restoration Plan shall take place during the initial development phase of the Landfill.

- 23.4 Sandstone Outcrop Area. Livestock fencing shall be constructed around the perimeter of the 72-acre sandstone area at the front of the Landfill to exclude cattle and preserve upland habitat area. Landfill personnel and construction operators shall be alerted regarding the protected area. Native trees such as Oak and California Buckeye shall be planted along the perimeter of this area. The adjoining equalization basin and toe berm shall be constructed to avoid damage to the protected area.
- 23.5 Weed Control Program. The landfill operator shall submit a weed control program to control introduced weedy species on the Landfill property as part of the Range Management Plan. The program is subject to approval by the County Conservation and Development Department. The weed control program shall include a list of noxious weeds, periodic monitoring of these species, and a weed control and removal program.
- 23.6 Phased Construction. The Landfill operator shall construct and operate the Landfill in phases in order to reduce the acute impact to vegetation and wildlife habitat. Mature trees should be removed only as needed, not more than one year in advance of module development. Black walnut and other heritage tree cuttings shall be taken with the direction of a research organization such as the University of California's botanical garden.
- 23.7 Vegetation Protection. The Landfill developer shall employ dust suppression measures to prevent damage from dust loading on vegetation. Periodic watering of vegetation adjacent to the fill working area shall be developed as part of the Range Management Plan.
- 23.8 Wildlife Exclusion and Vector Control. The Landfill operator shall construct fences around the working area of the site, limit the size of the working face, and cover refuse at least daily in order to exclude wildlife and control vectors at the working area of the site.
- 23.9 Supplemental Wildlife Surveys. The Landfill developer shall conduct additional surveys to establish the presence or indicate the absence of the following species at the landfill site.
  - a) San Joaquin Pocket Mouse. The survey shall be conducted according to USFWS recommendations. If found, the developer shall follow USFWS guidelines regarding appropriate mitigation

procedures.

- b) The California Tiger Salamander and the Alameda Whipsnake. The salamander study shall take place during the rainy season. If salamanders are found to exist in the unnamed creek, they shall be trapped and released to the Lawlor Creek area. If the Alameda Whipsnake is encountered, then facilities such as the equalization basin, and the access road shall be relocated further from the outcrop area. The outcrop reserve shall be expanded to include the easternmost outcrops. Consideration shall be taken in siting facilities and any activities north of access road. Lighting shall be shielded and shall illuminate only paved areas in this vicinity.

## **24. BIRD AND VECTOR CONTROL**

- 24.1 Bird and Vector Control Objective. The Landfill operator shall manage the facility in such a manner that prevents and controls the attraction and/or generation of birds and vectors at the site.
- 24.2 Soil Cover Frequency. See Condition 20.3.
- 24.3 Working Face. See Condition 17.17
- 24.4 Bird Control. If birds become a problem at the Landfill in the judgement of Contra Costa Environmental Health, the Landfill operator shall institute a contingency bird control program. Such a program may consist of monofilament or wire lines suspended in the air at appropriate intervals over and around the active disposal area. The Landfill operator shall retain a biologist during the initial period of operation to (1) assess the effectiveness of the monofilament line for bird control and (2) assess the effect of the line on avian predator species. If necessary, additional corrective measures shall be taken at that time. Such measures may include a reduction in the size of the working face of the landfill, the use of nets over the working face, or the use of a habitat manipulation and modification program.
- 24.5 Rodent Control. If waste compaction does not eliminate live rodents from the Landfill footprint, or if rodents (other than small numbers of field mice, etc.) occupy facility landscaping or agricultural areas, the operator shall work with the local enforcement agency to identify the reasons for the presence of rodents and make appropriate changes in operational procedures. If an eradication program is necessary, the use of alternative rodent control programs such as sustained live trapping using nonpoisonous baits, and natural biological control shall be considered. Anti-coagulants shall be administered by a pest management professional in a manner which minimizes exposure to avian predators. Class 1 pesticides shall not be

used.

- 24.6 Mosquito Control. The Landfill operator shall grade areas within the Landfill property to prevent ponding of water which could harbor mosquitos (except for sedimentation ponds and riparian habitat areas). Sedimentation ponds shall be stocked with mosquito fish unless otherwise specified by the Mosquito & Vector Control District. If a mosquito problem persists, Contra Costa Environmental Health may require the preparation and implementation of additional mosquito control measures, such as spraying of non-toxic larval suppressant.
- 24.7 Fly Control. The Landfill operator shall limit the size of the working face and shall cover refuse daily in order to prevent fly proliferation. If an eradication program is necessary, the use of a pest-control specialist shall be considered and a plan implemented pursuant to approval by Contra Costa Environmental Health.

## **25. LITTER CONTROL**

- 25.1 Litter Control Objective. The Landfill operator shall manage the facility in a manner which confines litter to the working face of the Landfill, which prevents litter from accumulating another parts of the site, and which prevents litter from being blown off the site.
- 25.2 Load Covering. The Landfill operator shall implement a program requiring landfill users (customers) to securely containerize their load to avoid littering and exclude uncovered loads from arriving at the Landfill consistent with the requirements of Section 418-2.008 of the County Code. The program shall be subject to the approval of the County Department of Conservation and Development and Contra Costa Environmental Health. See also Condition 7.2.
- 25.3 Load Cover Enforcement. If routine enforcement of load cover requirements is not effective, the Landfill operator shall offer to contract with the Sheriff's Department to enforce regulations requiring the covering of trucks and trailers.
- 25.4 Contingency Litter Control. Under windy conditions, the Landfill operator shall cover the refuse with County approved cover materials as often as necessary to control blowing litter. Other options shall be considered as necessary, including the alignment of unloading areas away from the prevailing wind direction, increasing the number of compactors, decreasing the active face size, and reducing the number of vehicles tipping at one time. The Contingency Litter Control measures shall be contained in the Litter

Control and Prevention Program that is subject to review and approval of the Department of Conservation and Development and Contra Costa Environmental Health. Contra Costa Environmental Health shall have the authority to enforce this requirement. See Section 20.8.

- 25.5 Portable Litter Fences. The Landfill operator shall install portable fencing near the working face of the Landfill to intercept wind-blown debris.
- 25.6 Permanent Litter Fence. The Landfill operator shall install a permanent fence of wire around the current fill area of the Landfill. The location shall be subject to the approval of Contra Costa Environmental Health.
- 25.7 On-Site Litter Policing. The Landfill operator shall remove litter from the litter fences and planting screens at least once each day. On-site roads, including 500 feet of Bailey Road south of the site entrance, shall be policed at least daily. Contra Costa Environmental Health may require more frequent policing to control the accumulation of litter.
- 25.8 Off-Site Litter Policing. The Landfill operator shall provide weekly (or more frequent) litter clean-up along Bailey Road from Highway 4 to at least 500 feet south of the site entrance. Based on experience, the County Department of Conservation and Development or Contra Costa Environmental Health may modify frequency of clean-up and/or area of coverage. If wind-blown litter from the landfill reaches other properties, the Director of Environmental Health or the Director of Conservation and Development may require the Landfill operator to remove the litter and the Director(s) may require the operator to institute additional measures to prevent recurrence of the problem.
- 25.9 Littering Signs. The Landfill operator shall post signs, as determined necessary by the County Public Works Department, along access roads to the Landfill noting littering and illegal dumping laws. The Landfill operator shall post signs at the Landfill entrance noting the hours when the Landfill is open. The operator should periodically publish these laws and operating hours in mailings to Landfill clientele.
- 25.10 Clean-Up Bond. The Landfill developer shall deposit a surety bond for \$10,000 payable to the County to use for clean-up in the event of emergency or disputed littering or spills.
- 25.11 Public access. Public access to the landfill shall be prohibited unless such access is provided for special events, such as tours, open house functions or wetland field trips for local schools.

## **26. PUBLIC HEALTH AND SAFETY**

- 26.1 Safety Objective. The Landfill operator shall manage the facility in a manner which does not impair the safety of persons living in its vicinity, Landfill users, or Landfill employees.
- 26.2 Emergency Plan. The Landfill operator shall prepare an emergency plan specified by the Solid Waste Facilities Permit and approved by Contra Costa Environmental Health. The emergency plan shall include the following:
- (a) A fire and explosion component.
  - (b) A seismic component.
  - (c) A hazardous waste spills and contamination containment component.
  - (d) An evacuation component.
- 26.3 Employee Safety Equipment. The Landfill operator shall provide or require employees to provide safety equipment, such as safety glasses, hard hats, safety shoes, gloves, coveralls, and noise reducers as required by state and federal safety agencies and Contra Costa Environmental Health.
- 26.4 Employee Training. The Landfill operator shall develop and implement training and subsequent refresher training programs covering accident prevention, safety, emergencies and contingencies ("bad-day" scenarios), gas detection, identification of hazardous materials and ground fissures, first aid, and instruction in the use of equipment. The programs shall be subject to the approval of Contra Costa Environmental Health.
- 26.5 First Aid Equipment. The Landfill operator shall provide and maintain supplies located in easily accessible areas. The first aid supplies shall be consistent with the Occupational Safety and Health Administration requirements and subject to the approval of Contra Costa Environmental Health.
- 26.6 Emergency Communications. The Landfill operator shall provide radio phones or telephones for employee use to call for medical and other emergency assistance. Phone numbers to use for outside emergency assistance shall be clearly posted on the Landfill and in other work areas. The communications system shall be subject to the approval of Contra Costa Environmental Health.
- 26.7 Emergency Eye Baths and Showers. The Landfill operator shall provide facilities for emergency eye baths and emergency showers. The facilities shall be subject to the approval of Contra Costa Environmental Health.

- 26.8 Equipment Maintenance. The Landfill operator shall prepare and implement an equipment maintenance program which shall be approved by Contra Costa Environmental Health prior to the commencement of operations. The program shall address transfer vehicles and other refuse-conveying vehicles stored on the site as well as the station's refuse-moving vehicles and mechanical equipment. Vehicles and equipment shall be regularly cleaned to reduce the risk of fires.
- 26.9 Gas Migration Monitoring. The Landfill operator shall prepare and implement a gas migration monitoring program to detect underground gas migration. Landfill buildings and paved areas within 1,000 feet of the Landfill disposal area shall be monitored unless otherwise specified in state regulations. The monitoring program shall be approved by Contra Costa Environmental Health.
- 26.10 Refuse Cover. See Condition 20.3.
- 26.11 Load Inspection. See Condition 7.1.

## **27. SITE SECURITY**

- 27.1 Security Objective. The Landfill operator shall manage the facility in a manner which prevents unauthorized persons from having access to the working areas of the Landfill both during and after operating hours.
- 27.2 Security Fencing. The Landfill developer shall install a security fence around the perimeter of the site with lockable gated entrances and exits. The fence shall be located to minimize its visual impacts. It shall be included in the Development and Improvements Plan.
- 27.3 Security Staffing. The Landfill operator shall staff the Landfill 24 hours per day. Private security services may be retained when the site is not open to patrol and/or aid with investigating after hours odor complaints (see Condition 20.2) as needed.
- 27.4 Security Lighting. The Landfill developer shall install and operate adequate lights at the entrance area to the Landfill. The lighting shall be provided in a manner which minimizes glare to nearby residents and road users. The security lighting shall be covered in the Development and Improvements Plan.

## **28. CULTURAL RESOURCES**

- 28.1 Cultural Resource Preservation Objective. The Landfill developer shall construct the facility in such a manner that preserves important archaeological or historic sites.
- 28.2 Employee Access. Employee access to the buffer area, the Lawlor Creek area, or the sandstone outcrop area shall be limited to duties associated with landfill maintenance. Artifact collection or vandalism in these areas shall be strictly prohibited.
- 28.3 Archaeology. The Landfill operator shall cease work in the immediate area if buried human remains or archaeological features (e.g., petroglyphs) are uncovered during construction or operation. Work in the immediate area shall cease until a qualified archaeologist is consulted and approves resumption of work. Should human remains which may be of Native American origin be encountered during the project, the County Coroner's Office shall be contracted pursuant to the procedures set forth in the Health and Safety Code. The County Conservation and Development Department shall also be notified.

## **29. TRANSPORTATION AND CIRCULATION**

- 29.1 Traffic Objective. The Landfill operator shall manage the facility in such a manner that provides safe, efficient transport of solid waste, while minimizing impacts to County residents.
- 29.2 Access Route. Access to the landfill facility shall be via State Highway 4, and Bailey Road unless alternate routes are approved by the County Department of Conservation and Development on an interim basis. No waste-hauling traffic shall be allowed entrance to the landfill from Bailey Road south of the site. The Landfill operator shall specify use of the prescribed route in all user contracts and shall notify non-contract users of the requirement. At the request of the Board of Supervisors, the Landfill Operator shall reimburse the County for the cost of enforcement of this Condition on the access route. The Board of Supervisors may also request the Landfill operator to reimburse the City of Concord for an access control police inspection stop on Bailey Road should it become necessary to enforce this access route condition.
- 29.3 Landfill Access Road. The Landfill developer shall install a paved, two-lane access road between Bailey Road and the edge of the current working lift of the landfill. A facility parking lot, a bridge across Lawlor Creek, a 12-foot turnaround lane, and parking/turn-off lanes shall be provided. the traffic



lanes shall be built to a suitable Traffic Index (between 10.0 and 10.5). The roadway shall be constructed of all-weather driving surfaces of not less than 20 feet of unobstructed width, and not less than 13'-6" of vertical clearance, to all landfill areas within the site. The road shall not exceed 20% grade, shall have a minimum centerline turning radius of 30 feet, and must be capable of supporting the imposed loads of fire apparatus (20 tons). The access road shall be operational when the landfill opens. All costs shall be borne by the Landfill developer. The design and specifications of the roadway shall be approved by the County Public Works and Conservation and Development Department in consultation with the applicable Fire Protection District.

- 29.4 Landfill Entrance. The Landfill developer shall construct the Bailey Road entrance to the site in a manner that provides safe access into the landfill. This improvement shall include the following for proper sight distance and intersection design: a separate left turn lane at least 150 feet in length and an acceleration lane, at least 1200 feet in length, leading north on Bailey Road, away from the site. The landfill developer shall also become responsible for a traffic signal at a later date, if warranted. The County Public Works Department shall approve the design of the entrance and estimate its cost. All costs shall be borne by the Landfill developer.
- 29.5 Bailey Road, Pittsburg city limits to the Landfill Entrance. The Landfill developer shall reconstruct the sections of Bailey Road between the city limits and the landfill entrance. The reconstructed roadway shall provide the sight distance, and roadway geometrics (including shoulder widening) specified by the County Public Works Department for truck use. This shall include two twelve-foot lanes with eight-foot shoulders. These improvements shall be in place prior to commencement of landfill operations. The Landfill developer shall upgrade the pavement capacity to reflect a 20-year life (an estimated Traffic Index of 10.0 - 10.5) along Bailey Road between the Pittsburg city limits and the landfill entrance. The County Public Works Department shall approve the design of the roadway and pavement reconstruction and estimate its cost. All costs shall be borne by the Landfill developer.
- 29.6 Bailey Road Pavement Study. The Landfill developer shall conduct a study of the Bailey Road roadway from the Pittsburg city limits to the Highway 4 interchange to determine the improvements necessary to re-construct the right hand (outside) traffic lanes of the road to a 20-year pavement standard to be an estimated Traffic Index of 10.0 to 10.5. The County Public Works Department, in consultation with the City of Pittsburg, shall estimate the costs of the improvements, estimate the longevity of the existing roadway under increased traffic conditions, and determine a per-ton refuse disposal surcharge adequate to fund the improvements when reconstruction is

necessary. The Landfill operator shall impose the surcharge and pay it quarterly into a segregated account established by the County. The design of the improvements, their costs, the surcharge and its disbursement shall be approved by the Board of Supervisors.

- 29.7 Road Maintenance. Subsequent to the funding of the above traffic lane upgrading improvements, the landfill operator shall impose a surcharge for the maintenance of Bailey Road between the Highway 4 interchange and the Landfill intersection. The surcharge shall be estimated by the County Public Works Department in consultation with the City of Pittsburg and shall be based on the landfill's proportionate share of traffic on the road corridor adjusted for vehicle weight and number of axles. The fees shall be paid quarterly into a segregated account established by the County. The design of the improvement, its cost, the surcharge and disbursements from the segregated account shall be approved by the Board of Supervisors.
- 29.8 Highway 4/Bailey Road Interchange. The Landfill developer shall participate in an improvements district, benefit area, or other cooperative arrangement with the County, the City of Pittsburg, and Caltrans which may be created to improve the Highway 4/Bailey Road Interchange. The developer shall be required to pay an amount for the improvements and maintenance proportionate to the traffic generated by the landfill, adjusted for truck use. If necessary, the developer shall advance the money for the interchange design and improvements. The County Public Works Department shall approve the design of the interchange and estimate its cost. The fees shall be paid quarterly into a segregated account established by the County. The design of the improvements, their costs, the surcharge, and disbursements from the segregated account shall be approved by the Board of Supervisors.
- 29.9 Peak Period Traffic Management. The Landfill operator shall prepare a study, in conjunction with the local transfer station(s) serving the landfill, for managing transfer vehicle traffic to reduce peak period conflicts with traffic on Highway 4. The study shall address the restricted departure periods from the Landfill identified in the Environmental Impact Report (6:30 - 8:30 a.m. and 3:30 - 6:30 p.m.) and shall identify any changes to the conditions of approval needed to implement a peak-period traffic reduction program. The study shall be approved by the County Public Works and Conservation and Development Departments and shall be provided with the Development and Improvements Plan. The Director of Conservation and Development has imposed the peak period traffic restrictions identified in a) and b) below. The Director of Conservation and Development may specify any additional peak period traffic restrictions deemed to be warranted. The Landfill operator shall comply with such restrictions, and shall require compliance in contracts with Landfill users.

- a) The A.M. peak period departure from the landfill shall commence at 7:10 a.m.
- b) A three minute interval shall be maintained between waste hauling vehicles en route to Highway 4 westbound during the period of 7:10 a.m. and 8:30 a.m.
- c) Waste hauling vehicles en route to eastbound Highway 4 (the uncongested “reverse commute” direction) may be released without restriction.

29.10 Bicycle and Pedestrian Improvements. The Landfill developer shall incorporate into the Transportation and Circulation Plan a bicycle and pedestrian path system along Bailey Road in the vicinity of the landfill.

### **30. SITE SERVICES AND UTILITIES PLAN**

Site Services and Utilities Objective. The Landfill developer shall design, develop and manage the facility in such a manner that services and utilities adequately meet the landfills requirements, while ensuring the protection of site employees, area residents, and the surrounding environment.

30.1 Final Site Services and Utilities Plan. The landfill developer shall prepare and submit a final Site Services and Utilities Plan, and obtain the approval of the County Conservation and Development Department prior to beginning construction. The Site Services and Utilities Plan shall be included in the Development and Improvements Plan. The final Site Services and Utilities Plan shall include:

- a) A water service component. (see Condition 30.2)
- b) A fire protection component. (see Condition 30.5)

30.2 Water Service Component. The Landfill developer shall prepare and implement a Water Service Component, covering available water resources, estimated total water needs and supplies, landfill construction and operation, landscaping, fire protection, employee hygiene, and human consumption water needs, and water supply sources. Potable water shall be provided for hygiene and consumption. Potable water may be trucked onto the Landfill.

30.3 On-site Water Wells. The Landfill operator shall install wells for water supply with a minimum pumping capacity of 1,000 gallons per minute, or must have on-site storage which produces this capacity. The County Conservation and Development Department and Contra Costa Environmental Health shall be furnished pumping test information which

shall be submitted with the Development and Improvement Plan.

- 30.4 Public Water Supply Option. The Landfill operator may substitute water service from a public water supply system for the use of wells, if arrangements can be made with the Contra Costa Water District and, where applicable with the cities of Concord or Pittsburg. The water supply may be potable or non-potable. Annexation to the Contra Costa Water District probably would be required, as well as an approval for annexation from the Local Agency Formation Commission, and would have to be obtained prior to the submission of the Water Service Plan as part of the Final Development and Improvements Plan. The size and placement at the water supply line shall be included in the Water Service Plan and shall be subject to the approval of the Contra Costa Environmental Health and Conservation and Development Departments.
- 30.5 Fire Protection Component. The Landfill operator shall develop and implement a Fire Protection Component meeting the requirements of the applicable Fire Protection District to contain and extinguish fires originating on the landfill property and off-site fires caused by Landfill operations. It shall include training for all employees. The program shall be subject to the approval of Contra Costa Environmental Health.
- 30.6 Fire District Programs. The Landfill developer shall participate in the applicable Fire Protection Districts Benefit Assessment Program and the New Development Fees program.
- 30.7 Construction Timing. Access roads and water supply systems shall be installed and in service prior to any combustible construction and/or related landfill activity. No construction, excavation, or grading work shall be started on this landfill facility until a plan for water supply system has been submitted to and approved by Contra Costa Environmental Health and the County Conservation and Development Department. Water may be transported onto the site during construction activities, but trucked water shall not be used for ongoing landfill activities.
- 30.8 On-Site Water Storage. The Landfill developer shall provide an adequate and reliable water supply for fire protection which shall include on-site storage. The storage tank(s) shall have a useable capacity of not less than 240,000 gallons of water and shall be capable of delivering a continuous flow of 1,000 gallons per minute.
- 30.9 Fire Fighting Water Main. If the Landfill developer exercises the alternative of utilizing public water supply, an above-ground main of sufficient size and quantity shall be provided, which when connected to the respective storage tank, shall be capable of supplying the required portable monitor (see

Condition 30.11) with a minimum fire flow of 1,000 GPM delivered to the working face of any open cell in the landfill operation.

- 30.10 Fire Cover. The Landfill operator shall store a supply of soil nearby the working face to be used for fire suppressant. The adequacy of the cover stockpile shall be determined by Contra Costa Environmental Health in cooperation with the applicable Fire Protection District.
- 30.11 Fire Fighting Appliance. The Landfill operator shall provide a minimum of one (1) approved portable master-stream firefighting appliance (monitor) located within fifty (50) feet of each working face of any open cell in the landfill.
- 30.12 Fire Breaks. The Landfill developer shall provide and maintain firebreaks as follows: a) A minimum 100-foot firebreak around the perimeter of each landfill disposal area, b) A minimum 60-foot firebreak around the perimeter of the entire site and around any buildings or similar structures. The firebreaks shall be placed to minimize any adverse visual effects. Their locations shall be subject to the approval of the applicable Fire Protection District. The firebreaks shall be included in the Development and Improvements Plan.
- 30.13 Fire Extinguishers. The Landfill operator shall provide landfill equipment with fire extinguishers large enough to fight small fires on the equipment or on the landfill. The extinguishers and their distribution shall be subject to the approval of Contra Costa Environmental Health and the applicable Fire Protection District.
- 30.14 Use of Reclaimed Water for Landscaping. The Landfill Developer shall make every effort to use treated waste water from a district sewage treatment plant for landscape maintenance. The Landfill Developer shall report on this matter to the Conservation and Development Department.
- 30.15 Equipment and Cleaning. See Condition 20.24.
- 30.16 Smoldering Loads. The Landfill operator shall check incoming loads and direct vehicles hauling smoking or burning trash to a designated place apart from the current fill area. The loads shall be dumped immediately and the fire extinguished before the waste is incorporated into the fill.
- 30.17 Emergency Equipment Access. The Landfill operator shall designate access points for local fire protection agency access to all parts of the landfill and routes. The access points shall be included in the Development and Improvements Plan and shall be subject to the approval of the applicable Fire Protection District.

- 30.18 Smoking Prohibitions. The Landfill operator shall prohibit smoking on the landfill except in designated areas. In no event shall smoking be allowed near the working face of the landfill and the fuel storage area. Signs shall be clearly posted and enforced.
- 30.19 Toilets. The Landfill operator shall provide portable chemical toilets near the active disposal area for use of workers and drivers. Their placement and maintenance shall be subject to the approval of Contra Costa Environmental Health.
- 30.20 On-site Septic System. Septic systems shall be designed to County Department of Health Service Standards, and State Health and Safety Code requirements. The Landfill developer shall pay for any treatment plant fees.
- 30.21 Sewer Line. In the event that the Landfill developer elects to connect to a sewer line, the developer shall pay for any capacity studies required, and any resultant equipment and/or facilities.

## **31. WASTE REDUCTION AND RESOURCE RECOVERY**

- 31.1 Waste Reduction and Resource Recovery Objective. The Landfill operator shall manage the facility in such a manner that complies with the State's waste management hierarchy of source reduction, recycling and composting, and environmentally safe transformation and land disposal; and that is consistent with the Countywide Integrated Waste Management Plan.
- 31.2 1990-1995 Resource Recovery Program. The Landfill Operator shall participate with the transfer station(s) operators(s), route collection companies and direct haulers in designing and implementing a resource recovery and recycling program for the service area which is consistent with the goal of diverting 25 percent of all solid waste generated in the County from landfill facilities by January 1, 1995.
- 31.3 1996-2000 Resource Recovery Program. Prior to 1995, the Landfill operator shall prepare and submit for review and approval by the County Conservation and Development Department a resource recovery and recycling program for the service area covering the period from 1996-2000. This shall be consistent with the Countywide Integrated Waste Management Plan's goal of diverting a total of 50 percent of all solid waste generated in the County from landfill facilities by January 1, 2000.
- 31.4 Materials Recovery. The Landfill operator shall prepare and implement a Material Recovery Program for recovering recyclable materials (e.g.

construction and demolition debris) from refuse loads brought directly to the landfill. The Program shall describe in detail all existing and proposed on-site recovery activities and the associated percent of waste diversion for each, including materials diverted for use as cover, on-site beneficial reuse as well as transported off-site (e.g. biomass facilities). The Program shall include proposed on-site recovery activities intended to handle source separated loads and comingled loads to be sorted on-site to increase diversion, if applicable. The Program shall be consistent with the Countywide Integrated Waste Management Plan. The landfill operator shall record and report the weight of all material(s) recovered through the Material Recovery Program. Each type of recovered material being diverted must be weighed for reporting purposes. Materials accepted for beneficial reuse or ADC, which are subsequently deemed unsuitable and must therefore be disposed of, shall be weighted and reclassified for the purposes of reporting and fee calculation. Incoming quantities required to be tracked and reported by waste type and jurisdiction of origin, pursuant to Conditions 8.7 and 10.3 must accurately differentiate between the tons disposed, beneficially used on-site or sent off-site. Quarterly disposal reports must also accurately reflect the destination and tonnage of each type of recovered material sent off-site, if applicable. The Program shall be subject to the approval of the County Department of Conservation and Development.

- 31.5 Composting Project. The Landfill operator shall develop and implement a program for composting organic material. The program may occur at the landfill site, off-site or in coordination with third party(ies), and shall be approved by Contra Costa Environmental Health and the Department of Conservation and Development. The compost shall be used for landfill landscaping, cover material or other approved on-site uses; alternatively, compost can be made available or sold off-site. The purpose of the composting program shall be to implement a cost effective and feasible means of providing adequate local organics diversion capacity through large-scale composting. The composting operations shall be subject to regulatory and permitting requirements enforced by Contra Costa Environmental Health, the Air District and the Water Board. No later than January 1, 2016, the Landfill operator shall submit substantiation that they have applied for the required regulatory approvals (permits) processes necessary to conduct large-scale composting or demonstrate that arrangements are underway to implement an equivalent off-site program. The Landfill operator shall make all feasible efforts to assist the County in ensuring that there will be adequate composting capacity available to readily divert the organics waste stream generated in Contra Costa County which is currently used as Alternative Daily Cover (ADC) prior to the sunset of the ADC diversion credit on January 1, 2020.

- 31.6 Wood Chipping. The Landfill operator shall establish a program to encourage landscape services and construction/demolition debris haulers to segregate wood material for chipping and diversion from landfill disposal. The program may occur off-site, however unless and until there is on-site recovery (waste diversion as defined in the Integrated Waste Management Act) the Landfill operator shall direct these customers to deliver loads of landscaping and construction/demolition debris to facility(ies) that recover and chip wood material. The program shall be submitted for review and approval by the County Department of Conservation and Development and implemented on an ongoing basis following approval.
- 31.7 Methane Recovery. The Landfill operator shall explore the use of methane in landfill gas collected for air pollution reduction as a fuel commodity. The operator shall report findings to the Conservation and Development Department at the time of the landfill's periodic reviews. If there is an economic use found for recovered methane, and if the County subsequently includes the use in its Integrated Waste Management Plan, the Landfill operator shall implement a methane recovery program.
- 31.8 Equipment Maintenance. The Landfill operator shall maintain motorized landfill equipment to assure maximum fuel efficiency.
- 31.9 County Resource Recovery Management Program.
- a) When directed by the County, the Landfill operator shall impose a tonnage surcharge adequate to support a County Resource Recovery Management Program. The cost of the program to be supported by the surcharge shall not exceed \$100,000 at 1987 levels. If other solid waste disposal facilities are subject to this or a similar condition, the County may pro-rate the cost of the program among them according to a formula approved by the Board of Supervisors.
  - b) As provided for in Condition 2.3, where there is an inconsistency between this condition and the terms of the Landfill Franchise Agreement which effectively suspended the collection of this Resource Recovery Management Program Fee, the terms of the Landfill Franchise Agreement shall supersede Condition 31.9 (a) until such inconsistency no longer exists pursuant to Condition 2.3(d).
- 31.10 Fund Recovery. The Landfill owner may recover funds provided to the County in advance of the opening of the Landfill through subsequent rate adjustments or surcharges approved by the County. The County may pro-rate the cost of the program among other waste disposal facilities it approves which are subject to similar conditions.



## **32. CONSTRUCTION ACTIVITIES AND CONDITIONS**

- 32.1 Hours of Construction. The Landfill developer shall restrict outdoor construction activities to the period from 8:00 a.m. to 6:00 p.m. Monday through Saturday.
- 32.2 Exemption. The Landfill developer may request, in writing, and the Director of Conservation and Development may grant, exemptions to Condition 32.1 for specific times for cause. An example is the placing of concrete.
- 32.3 Access Roads. Before commencing landfilling operations, the Landfill developer shall install and pave the site access road from Bailey Road to the Phase I excavation area (see Initial Facilities Site Plan drawing of the Initial Development and Improvements Plan, Condition 16.1). This installation shall include the new bridge over Lawlor Creek and the turnaround lane. An area which can be used by the California Highway Patrol for vehicle inspection/weighing shall also be constructed.
- 32.4 Phasing Plan. The Landfill developer shall design a Phasing Plan setting forth a schedule of construction activities and projects, with detailed information provided on sensitive installations such as the landfill liner and the leachate collection and gas management systems. Sensitive installation projects shall be subject to inspection by the Geotechnical Inspector (Condition 23.6). The necessary installations of the Surface Drainage System (Condition 18.2) and Soil Erosion and Control Plan (Condition 18.4) shall be in place before major excavations commence in order to ensure controlled surface water runoff. Sediment in the sedimentation pond shall be monitored to control quality of runoff. Construction activities shall be timed to coincide with the dry season and low surface water flows.
- 32.5 Unstable areas. Areas determined to be unstable by the Stability Analysis performed for the landfill (condition 18.4) shall be excavated or retaining walls installed under the supervision of a Certified Engineering Geologist or a Registered Geotechnical Engineer.
- 32.6 Dust Suppression. The developer shall sprinkle or chemically treat graded areas, borrow sites, stock piles, and temporary pavements to control dust, as determined necessary by Contra Costa Environmental Health and the Bay Area Air Quality Management District.

### **33. CLOSURE AND POSTCLOSURE MAINTENANCE**

- 33.1 Submittal of Plan. The Landfill operator shall submit to the San Francisco Regional Water Quality Control Board, the California Department of Resources Recycling and Recovery, and Contra Costa Environmental Health a plan for the closure and the postclosure maintenance of the landfill as required by State law, but no later than upon application for a Solid Waste Facilities Permit. A copy of the closure and postclosure maintenance plan shall be submitted to the County Conservation and Development Department.
- 33.2 Funding of Closure and Postclosure Maintenance Plan. The Landfill operator shall submit to the Board of Supervisors or California Department of Resources Recycling and Recovery (CalRecycle) evidence of financial ability to provide for the cost of closure and postclosure maintenance in an amount not less than the estimated cost of closure and 15 years of postclosure maintenance as contained in the submitted closure and postclosure maintenance plan unless otherwise required by the State. Evidence of financial ability shall be in the form of a trust fund approved by the Board of Supervisors in which funds will be deposited on an annual basis in amounts sufficient to meet closure and postclosure costs when needed unless an equivalent financial arrangement is identified as acceptable to the Board of Supervisors. The Board of Supervisors determined that the State required financial guarantees approved and periodically reviewed by CalRecycle are equivalent and therefore adequate to satisfy this condition. The Landfill operator shall maintain a trust fund balance that equals or exceeds the requirements of state law or regulation notwithstanding, however, the trust fund balance shall be at least equal to the then current closure and postclosure cost estimate at such time the landfill has reached one-half of its permitted capacity. The Trust Fund balance requirement shall be appropriately adjusted if the landfill is closed in stages under Condition 33.4.
- 33.3 Revision to Plan and Cost Estimates. Should State law or regulation regarding the closure and postclosures maintenance plan or funding of the plan change at any time, the owner of the landfill shall submit any required changes to the closure and postclosure maintenance plan and/or evidence of financial ability to the Board at the same time as submittal to the applicable state or regional agency.
- 33.4 Staged Closure of the Landfill. The landfill owner or operator shall close the landfill in stages if compatible with the filling sequence and the overall closure plan.
- 33.5 Use of Landfill Following Closure. After active landfill operations have

ceased, the site shall be utilized for grazing purposes. The Board may require the owner of the landfill to deed all development rights for the landfill site to the County to ensure fulfillment of this condition.

- 33.6 Postclosure Maintenance. The Landfill operator shall institute a postclosure maintenance program to ensure that containment and monitoring facilities retain their integrity. If damaged areas are found, the operator shall notify the County and take remedial actions to prevent odor and landfill gas problems.

### **34. ABANDONED VEHICLE STORAGE**

- 34.1 Storage Requirement. The Landfill operator shall provide a minimum 10-acre area on the landfill site for the storage of abandoned vehicles awaiting salvaging, if required by the Board of Supervisors. The storage site operator shall accept only vehicles directed to the site by a law enforcement agency operating in Contra Costa County, which shall be responsible for the vehicle until its title is conveyed to a salvager. The site would provide storage only; operations of disposing, salvaging, and security of abandoned vehicles shall not be the responsibility of the operator. The site may be subject to further planning and development approvals, and would be subject to the California Environmental Quality Act. The storage of abandoned vehicles shall be subject to conditions set by Contra Costa Environmental Health, and may be subject to the approvals of regulatory agencies having jurisdiction.
- 34.2 Off-site Storage Option. The Landfill operator may establish the abandoned vehicle storage area at another location, which shall be subject to the approval of the County Conservation and Development Department.

### **35. SPECIAL CONDITIONS OF APPROVAL**

35.1 Transportation System Impact Fee. The Landfill operator shall pay to the County of Contra Costa a Transportation Impact Fee of \$2.00 per ton of waste received at the Landfill to mitigate the general impacts of the Landfill-generated traffic on the County's road system. The operator shall deposit the fee monies quarterly in a segregated account established by the County. The fee shall be considered to be a pass-through business cost for the purposes of rate setting. The fee shall be adjusted annually to reflect the current Consumer Price Index.



*The Board of Supervisors approved Amendment 1 to Land Use Permit 2020-89 on November 1, 1994 which stayed the operation of Conditions 35.1 and 35.2 as long as the new Condition 35.8 remains in full force and operation.*

- 35.2 Open Space and Agricultural Preservation Fee. The Landfill operator shall

pay to the County of Contra Costa an Open Space and Agricultural Preservation Fee of \$2.00 per ton on solid wastes received at the Landfill to mitigate the general impacts of the Landfill on open space, existing and proposed recreational facilities, and agriculture. The operator shall deposit the fee monies quarterly in a segregated account established by the County. The fee shall be considered to be a pass-through business cost for the purposes of rate setting. The fee shall be adjusted annually to reflect the current Consumer Price Index.

☆ *The Board of Supervisors approved Amendment 1 to Land Use Permit 2020-89 on November 1, 1994 which stayed the operation of Conditions 35.1 and 35.2 as long as the new Condition 35.8 remains in full force and operation.*

35.3 Property Value Compensation Program. The Landfill operator shall provide funding for the preparation of a property value compensation program study when requested by the County of Contra Costa. The study will address the means of determining the extent of property value losses or reductions attributable to Landfill impacts, such as aesthetics, noise, traffic, or pollution, and the means of compensating property owners for said losses or reductions. When a compensation program is adopted by the Board of Supervisors, the Landfill developer shall fund it in the manner specified by the Board. If the Board of Supervisors determines that progress on the implementation of a compensation program is not proceeding in a timely manner, the Board may require the use of a facilitator and/or an arbitrator. The fee shall be considered to be a pass-through business cost for the purposes of rate setting.

35.4 Resource Recovery Program Fee.

- a) The Landfill developer or operator shall pay to the County of Contra Costa a resource recovery program fee of \$200,000 annually, beginning July 1, 1990. The developer or operator shall deposit the monies in a segregated account established by the County. The extent of the fee shall be subject to reconsideration when a franchise or agreement is established for the Landfill. The resource recovery program fee from its inception shall be a pass-through business cost for the purpose of rate setting. The fee shall be adjusted annually to reflect the current Consumer Price Index.
- b) As provided for under Condition 2.3, where there is an inconsistency between this condition and the terms of the Landfill Franchise Agreement which effectively suspended this Resource Recovery Program Fee, the terms of the Landfill Franchise Agreement shall supersede Condition 35.4 (a) until such inconsistency no longer exists pursuant to Condition 2.3(d).

35.5 Violation of Prescribed Haul Route. Upon a receiving a written

determination from the County that a user of the Landfill has violated Condition 29.2 by using a prohibited access route, the Landfill operator shall impose on that user the sanction that is directed by the County. Such sanction may include a surcharge on the tipping fee, prohibition against accepting waste from that user for a designated period of time, revocation of County refuse-hauling license, or other sanction directed by the County. A system for reporting alleged violation and for monitoring enforcement data shall be established by the County and implemented by the Landfill operator.

35.6 Direct Property Acquisition Study. The Landfill operator shall study the appropriateness of direct acquisition of properties immediately adjacent to the project, and shall fund any acquisition program ordered by the Board of Supervisors. The study shall be consistent with the Environmental Impact Report and shall be completed prior to the issuance of a franchise agreement.

35.7 Adjoining Sites. This permit authorizes the use of the Keller Canyon Landfill site only for its specified waste disposal uses as set forth in these Conditions of Approval, and for no other uses. In particular, during the effective and operative periods of this Permit, the Keller Canyon site covered by this Permit shall not be used to provide access to, or to accommodate in any way the use of, any adjoining property for landfill purposes, unless the County has approved the use of such adjoining property for landfill purposes.

☆ 35.8 Mitigation Fee. The Landfill operator shall pay to the County of Contra Costa a fee, the amount of which may be set by the Board of Supervisors by a Board Order from time to time, which amount shall not be less than \$3.00 per ton and shall not be more than \$4.00 per ton, on solid waste received at the Landfill. The fee shall be used as directed by the Board in its sole discretion: 1) to mitigate general impacts of the Landfill-generated traffic on the County's road system, 2) to mitigate the general impacts of the Landfill on open space, existing and proposed recreational facilities, and agriculture, or 3) to mitigate any general impacts of the Landfill upon the surrounding community.

Conditions 35.1 and 35.2 of Land Use Permit 2020-89 are hereby stayed in their operation as long as Condition 35.8 remains in full force and operation. Should Condition 35.8 (or any portion of it) for any reason be set aside or stayed in its operation, then Conditions 35.1 and 35.2 shall be in full force and operation.

☆ ***Condition 35.8 was added when Amendment 1 to Land Use Permit 2020-89 was approved. The Board of Supervisors approved Amendment 1 on November 1, 1994 which stayed the operation of Conditions 35.1 and 35.2 as long as the new Condition 35.8 remains in full force and operation.***

## **36. LANDFILL GAS POWER PLANT**

- 36.1 Power Plant Design. The design of the Landfill Gas Power Plant project as approved is generally shown on the plans submitted to the Conservation and Development Department on October 16, 2001.
- 36.2 Ultimate Responsibility. These conditions of approval identify the Landfill Gas Power Plant operator as the party primarily responsible for implementing conditions involving the design, construction, improvements, maintenance and management of the power plant. However, ultimate responsibility for compliance with these conditions lies with the owner of the landfill.
- 36.3 Keller Canyon Landfill Land Use Permit. The construction and operation of the Landfill Gas Power Plant is also subject to all other conditions in Land Use Permit 2020-89 for the Keller Canyon Landfill, as appropriate.
- 36.4 Violation/Revocation. The Landfill Gas Power Plant owner and operator shall at all times comply with the provisions and requirements of these Conditions of Approval. A repeated violation of any of these Conditions as a result of the construction or operation of the Power Plant is cause for revocation of the Land Use Permit for the power plant.
- 36.5 System Safety. Risk of fire (from gas, oil, or electrical sources) shall be controlled through the use of flame sensors, ultraviolet (UV) radiation and methane detectors, and fire extinguishers. These components shall be installed at a minimum, in the power modules, exhaust and cooling packages, and other locations as required by Code.
- 36.6 Equipment and System Monitoring. Instrumentation shall be provided for all power plant equipment and systems which provide for a fully automated monitoring and warning system. This will include an automated switch to combustion flare if necessary. Additionally, routine monitoring of the gas extraction system and power plant facility shall be performed during normal business hours by at least one on-site operator.
- 36.7 Engines. Power plant facilities shall use lean burn internal combustion engines to meet BAAQMD regulations for oxides of nitrogen (NO<sub>x</sub>), carbon monoxide (CO) and volatile organic compounds (VOC).
- 36.8 Hazardous Materials. Landfill Gas Power Plant operator shall prepare and submit a Hazardous Materials Business Plan for the Power Plant in compliance with requirements of the Hazardous Materials Division of Contra Costa County's Health Services Department.

- 36.9 Emergency Response. Landfill Gas Power Plant operator shall submit a facility specific Emergency Response Plan and then implement and update as needed, said Plan.
- 36.10 Notification of Plant Upset or Accidental Release. Landfill Gas Power Plant operator shall notify the Conservation and Development Department immediately of any plant upset or accidental leakage or release of landfill gas. A written report of the cause of any plant upset and the corrective measures taken by the facility operator, shall be provided to the Conservation and Development Department within 72 hours after resolving an emergency.
- 36.11 Stormwater Pollution Prevention Plan (SWPPP). Landfill Gas Power Plant operator shall implement the Keller Canyon SWPPP (prepared in 1996 and as may be amended from time to time), for water resources protection measures in case of spill of coolant, oil, or other lubricant.
- 36.12 Facility Design. Power Plant facilities shall be painted Bronze Olive or other suitable color as approved by the Conservation and Development Department. Power Plant operator shall install a perimeter security fence to enclose the power plant.
- 36.13 Power Plant Landscape Plan. A Landscape Plan for the Power Plant site shall be submitted subject to the approval of the Conservation and Development Department. The location and types of landscaping proposed along the security fence shall be specified.
- 36.14 Construction. Upon completion of construction, all construction materials, including packaging materials, worker facilities, and debris will be removed from the site. Additionally during construction all excess materials shall be removed periodically, as needed.
- 36.15 Material Recycling. Whenever feasible, all oils, lubricants, and coolant shall be recycled rather than disposed. Prior to issuance of a building permit, the applicant shall submit a Debris Recovery Plan. Upon completion of construction, the applicant shall submit a Debris Recovery Report.
- 36.16 Implementation & Compliance Monitoring. The operator shall provide payment for costs associated with the Conservation and Development Department's monitoring of implementation and compliance with these Conditions of Approval.
- 36.17 Surcharge. A surcharge, if established by the County Board of Supervisors,

shall be paid to the County, by the operator, related to the sale of landfill gas or the sale of electricity produced by burning said gas.

### **History of Revisions**

*7/24/1990 – Original Approval*

*11/1/1994 – Amendment 1 (added COA 35.8)*

*6/25/2003 – Amendment 2 (added Section 36 “Landfill Gas Power Plant” – LP012115)*

*12/16/2014 – Permit Review Modification (modified conditions 20.3, 25.4, and 31.5)*

*9/22/2015 – Permit Review Modification (modified multiple COAs and added COAs 2.3, 8.5, 8.6, 8.7, and 8.8)*

M:\Keller\LUP COAs\KCL-LUPCOA\_Modification 9-22-2015.docx



# EXHIBIT B

SEC 25 & POR SEC 23,24,26,35,36 T2N R1W &  
POR SEC 19,30,31 T1N R1E MDB&M  
1-POR 32PM42 3/8/87A MS73-243  
2-POR 15PM44 1/22/89I MS89-15

## CITY OF PITTSBURG

1"=2000'

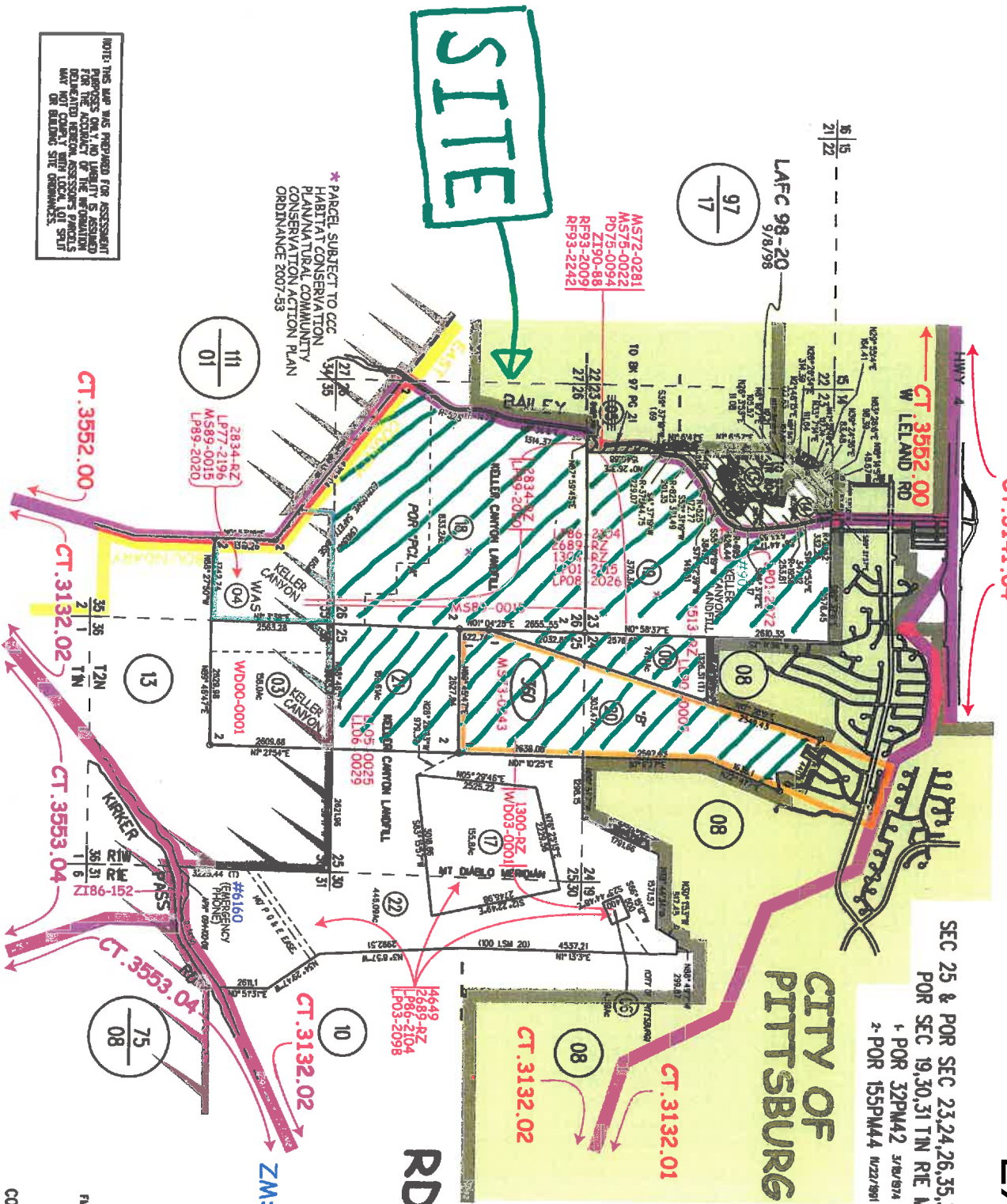

# RD. FEES

094 - 360 - 012  
BOOK PAGE PCL  
ZM: F-17/F-18/F-19  
G-17/G-18/G-19  
H-17/H-18/H-19  
J-18I

360  
22  
6200

NOTE: THIS MAP WAS PREPARED FOR ASSESSMENT PURPOSES ONLY. NO LIABILITY IS ASSUMED FOR THE ACCURACY OF THE INFORMATION DELIVERED HEREON. ASSESSOR'S PARCELS MAY NOT CORRELATE WITH LOCAL LOT SURVEY OR BUREAU SITE ORDINANCES.

\* PARCEL SUBJECT TO CCC HABITAT CONSERVATION PLAN/ANNUAL COMMUNITY CONSERVATION ACTION PLAN ORDINANCE 2007-93



Zoning: Heavy Agricultural, A-3 / Agricultural Preserve, A-4



Scale 1:15,131

Contra Costa Internet GIS Map  
Printed: Oct 13, 2014 1:37:47 PM





# General Plan: Landfill, LF / Open Space, OS

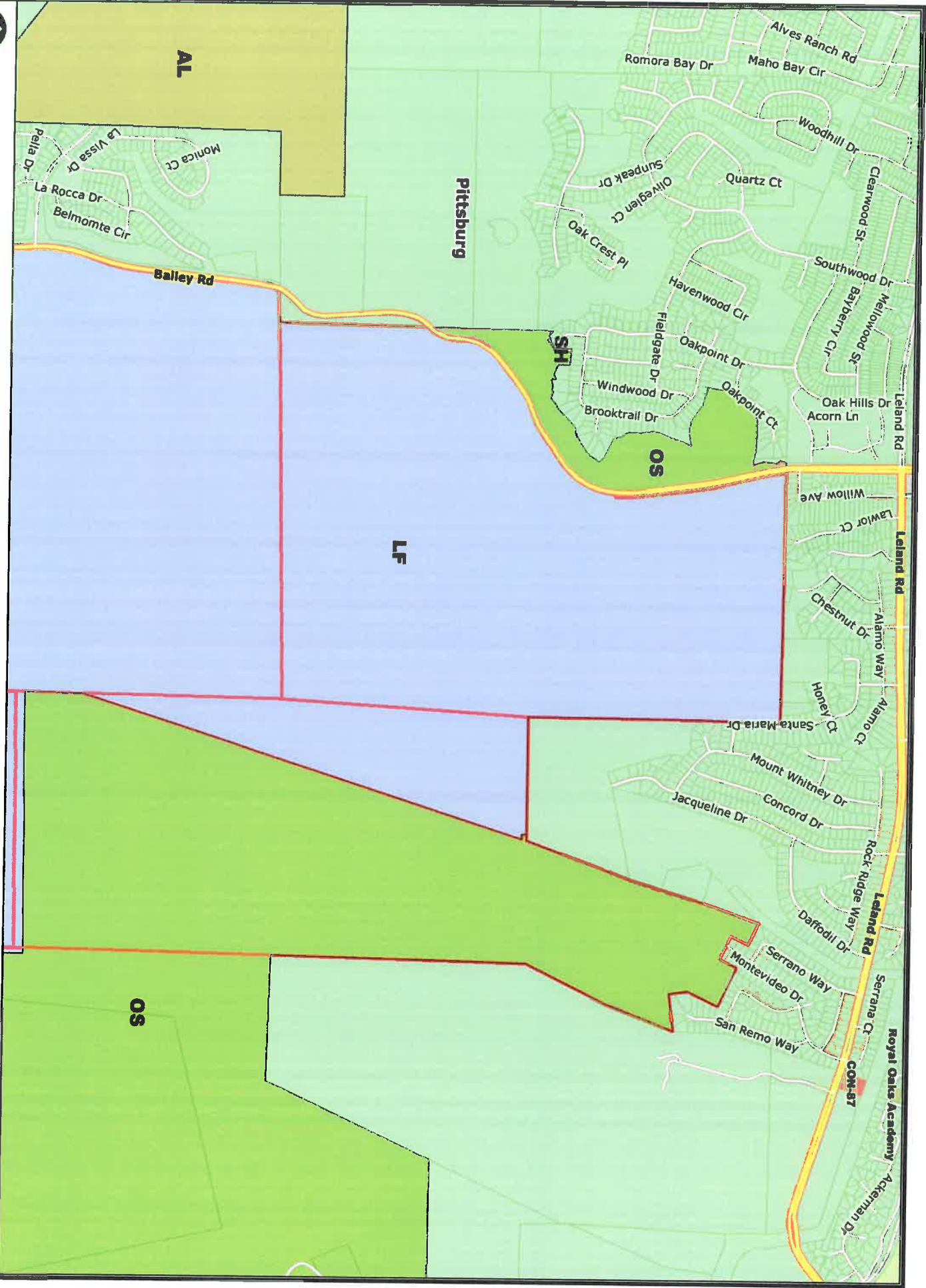

Scale 1:15,131  
 Contra Costa Internet GIS Map  
 Printed: Oct 13, 2014 1:39:23 PM



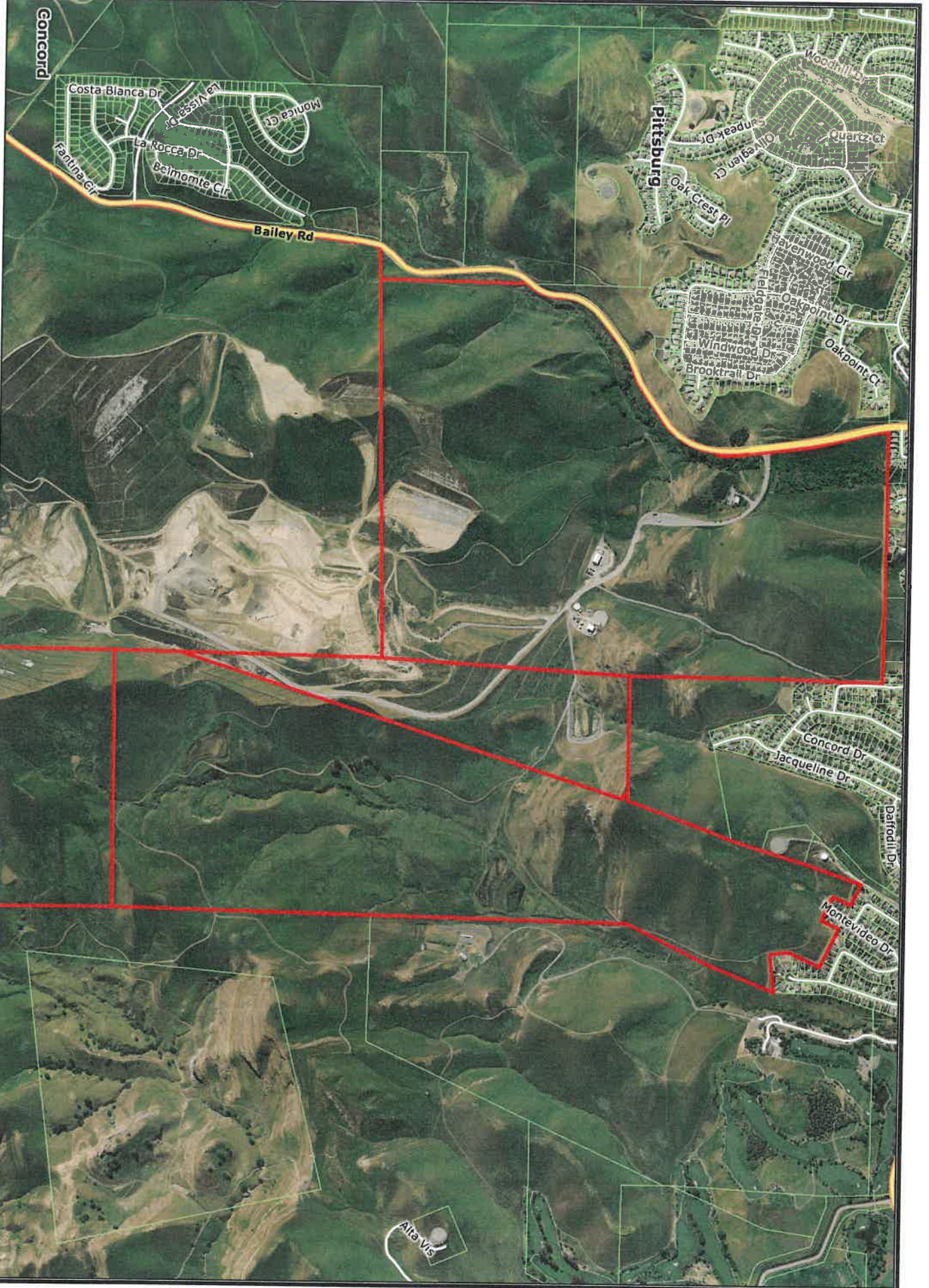

# Aerial Photograph

Scale 1:15,131  
Contra Costa Internet GIS Map  
Printed: Oct 13, 2014 1:41:20 PM



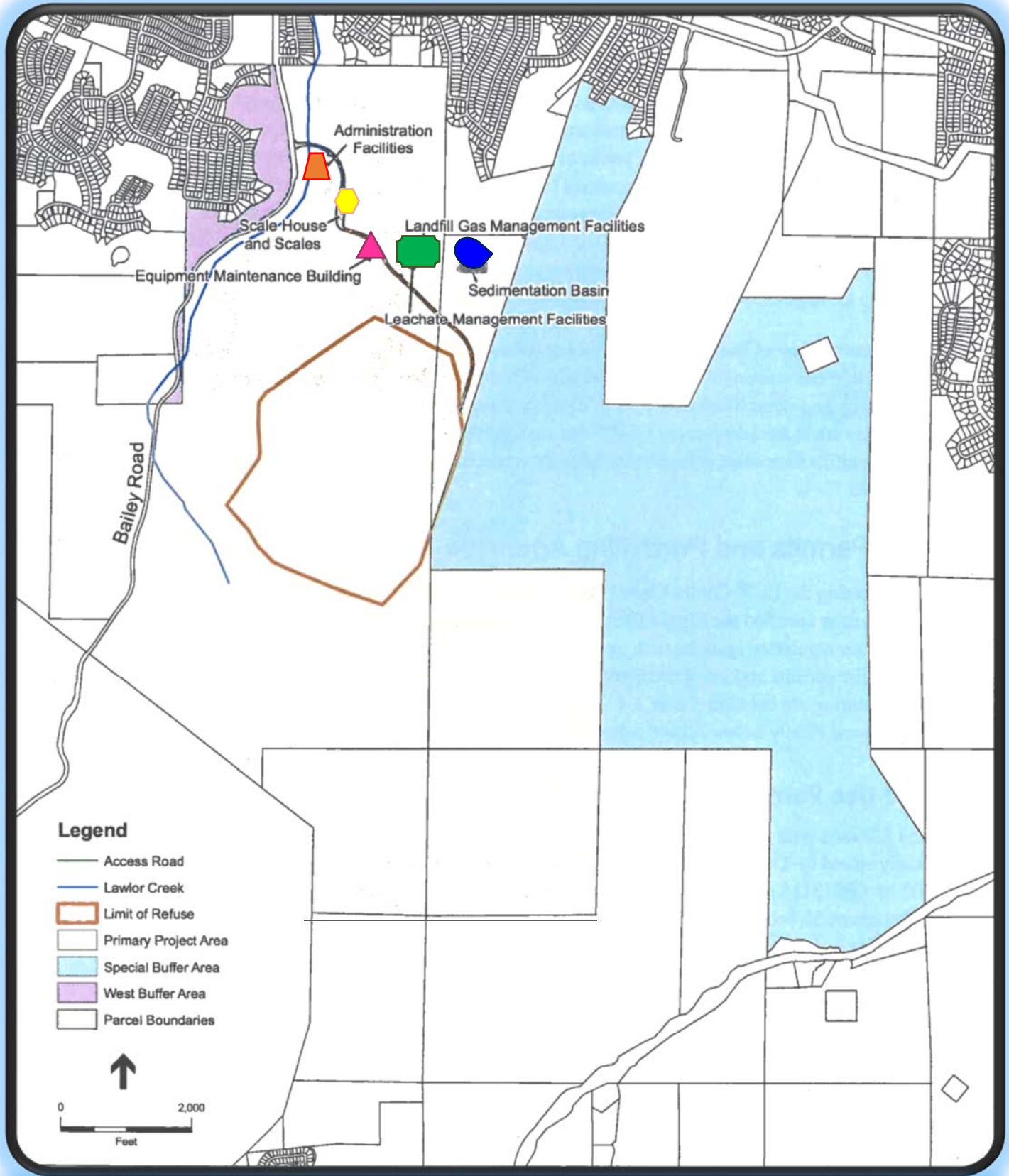

# Keller Canyon Landfill Site Map

901 Bailey Road, Unincorporated Pittsburg  
 Landfill Facilities & Disposal Area and Special Buffer Area



## Keller Canyon Landfill Aerial View

901 Bailey Road, Unincorporated Pittsburg  
Landfill Site and Surrounding Vicinity

TO: BOARD OF SUPERVISORS
FROM: VAL ALEXEEFF, DIRECTOR, GROWTH MANAGEMENT & ECONOMIC DEVELOPMENT AGENCY
DATE: June 20, 1995
SUBJECT: CRITERIA FOR REVIEW ON KELLER CANYON LANDFILL LAND USE PERMIT (LUP 2020-89)



SPECIFIC REQUEST(S) OR RECOMMENDATION(S) & BACKGROUND AND JUSTIFICATION

RECOMMENDATIONS:

- 1. Accept the staff submittal entitled Outline of Criteria, Review of Land Use Permit Conditions for Keller Canyon Landfill (Attachment 1).
2. Adopt criteria for the review of the Keller Canyon Landfill Land Use Permit Conditions of Approval at the Board meeting of June 20, 1995.
3. Refer the Conditions of Approval for the Keller Canyon Landfill Land Use Permit to the County Planning Commission for review pursuant to the Board's review criteria.
4. Direct staff to prepare a staff report on the above referred for consideration by the County Planning Commission.

FISCAL IMPACT

No General Fund impact. The review will be paid for by the permittee as a Land Use Permit Implementation/Mitigation Monitoring Program (I/MM) cost.

BACKGROUND:

The Board of Supervisors, on June 6, 1995, determined that a review of the Keller Canyon Landfill Land Use Permit Conditions of Approval should be performed through a referral to the County Planning Commission. Accordingly, the Board directed staff to prepare criteria to guide the review and to have the criteria considered by the Board at a public meeting. Staff's submittal is the attached document entitled Outline of Criteria, Review of Land Use Permit Conditions for Keller Canyon Landfill.

CONTINUED ON ATTACHMENT:

X YES

SIGNATURE:

[Handwritten signature]

RECOMMENDATION OF COUNTY ADMINISTRATOR APPROVE
RECOMMENDATION OF BOARD COMMITTEE OTHER

SIGNATURE(S):

ACTION OF BOARD ON June 20, 1995 APPROVED AS RECOMMENDED X OTHER X

Following presentation by Dennis Barry, Community Development Department, of the report on the above matter, and Board discussion of the issues, IT IS BY THE BOARD ORDERED that the recommendations 1,2,3, and 4 are APPROVED: AND THE City of Pittsburg and Browning Ferris Industries are INVITED to discuss whether to activate the Keller Canyon Landfill Advisory Committee or another process for community/citizen input in this process; and DIRECTED the Growth Management and Economic Development (GMEDA) staff to address the issue of definitions of classifications of waste.

VOTE OF SUPERVISORS

X UNANIMOUS (ABSENT)
AYES:
ABSENT:
ABSTAIN:

I HEREBY CERTIFY THAT THIS IS A TRUE AND CORRECT COPY OF AN ACTION TAKEN AND ENTERED ON THE MINUTES OF THE BOARD OF SUPERVISORS ON THE DATE SHOWN.

Attachment:

Contact: Charles A. Zahn (510) 646-2096
cc: Community Development Department (CDD)
County Administrator
County Counsel
County Health Services Department
Central and East County Cities
Central County Waste Management Authority
Browning-Ferris Industries
Citizens' United

ATTESTED June 20, 1995

PHIL BATCHELOR, CLERK OF THE BOARD OF SUPERVISORS AND COUNTY ADMINISTRATOR

BY: [Handwritten signature] DEPUTY

**ATTACHMENT 1**

**OUTLINE OF CRITERIA  
REVIEW OF LAND USE PERMIT CONDITIONS FOR  
KELLER CANYON LANDFILL**

**PART I  
BACKGROUND FOR REVIEW**

**A. AUTHORITY**

**1. Land Use Permit**

Condition 11.1 of Land Use Permit 2020-89 states the following:

**11.1 ADMINISTRATION**

Permit Review. The Board of Supervisors will hold annual public hearings to review the Conditions of Approval for this Land Use Permit for three years beginning one year after the commencement of operations of the Landfill. The Board may refer proposed changes to the Land Use Permit to the County Planning Commission for processing. Thereafter, the County Planning Commission shall hold public hearings on the Land Use Permit at three-year intervals. As a result of a review and public hearing, the County Planning Commission may recommend to the Board of Supervisors new or modified conditions to improve the public health, safety, and welfare. Nothing in this condition shall preclude the landfill owner from applying for amendments to the Land Use Permit at any time or preclude the County from addressing emergency situations or new requirements imposed by State or Federal legislation or the courts.

**2. Intent of Review**

**B. CONTEXT FOR THE REVIEW**

**1. Applicable Laws and Regulations**



2. Terms of Applicable Permits
  - a. Solid Waste Facilities Permit (LEA)
  - b. Waste Discharge Requirements (RWQCB)
  - c. Permit to Operate (BAAQMD)
  - d. Other Regulatory Agency Requirements
3. Compliance with CEQA; Consistency with Keller EIR
4. Vested Rights of Permittee
5. Demonstration of Compelling Public Necessity

C. STATUS OF EXISTING LAND USE PERMIT CONDITIONS OF APPROVAL  
(IMPLEMENTATION/MITIGATION MONITORING PROGRAM)

D. COMPLAINTS REVIEW

1. Complaints to CCDD and LEA
2. Complaints to Regulatory Agencies
3. Complaints to other Local Agencies

E. ISSUES RAISED

1. Construction Issues
2. Operating Issues (Except Special Wastes)

3. Special Wastes Issues
  - a. Direct Haul of Non-transferable MSW
  - b. Direct Haul of Designated Wastes
  - c. Contaminated Soils as Proposed Cover
  - d. Proposed Disposal of Asbestos Waste
4. Haul Route Issues
5. Other Transfer/Direct Haul Issues

**PART II  
REVIEW CRITERIA FOR  
COUNTY PLANNING COMMISSION**

**F. REVIEW CRITERIA FOR EXISTING CONDITIONS OF APPROVAL**

1. Changes Required by New Regulations
2. Changes Required by Court Decisions
3. Correction of Demonstrated Significant Health Impacts
4. Correction of Demonstrated Significant Safety Impacts
5. Correction of Demonstrated Significant Public Welfare Impacts

**EXHIBIT D - Compliance Status Table: Keller Canyon Landfill Land Use Permit 2020-89 Conditions of Approval**

<b>Status Types</b>	<b>Status Description</b>	<b># of COAs</b>
<b>Completed</b>	requirements were satisfied and no further action or monitoring expected. Brief remarks are provided in the adjoining Comments column.	43
<b>Completed. On-Going</b>	initial required action or submittal was completed and continuing landfill operations must be conducted in conformance with applicable submittal/requirements on an on-going basis.	32
<b>Completed. Updated As Needed</b>	submittal requirement was satisfied, but submittal addresses on-going or future activities and may be updated if/when warranted based on operating experience or requirements imposed by regulations or another permit/regulatory agency.	8
<b>Cross-Reference</b>	solely refers to one or more other conditions and does not contain any additional requirements.	19
<b>Further Review Required</b>	compliance status has not yet been confirmed pending completion of further review and/or coordination with other regulatory agencies.	2
<b>In Compliance. On-Going</b>	compliance with general requirements of conditions involving facility design standards, daily operations, or scheduled monitoring.	124
<b>Informational</b>	primarily informational and does not require specific actions.	13
<b>In Process</b>	applicable compliance efforts are underway but not yet completed.	3
<b>No Longer Applicable</b>	determined to be unenforceable or infeasible subsequent to issuance of the KCL LUP in 1990. Examples include conditions superseded by regulations; conditions that no longer apply due to U.S. Supreme Court decisions. Explanation is provided in the adjoining Comments column.	8
<b>Not in Compliance</b>	further action is required by the operator to fully satisfy requirement(s), includes any that were only partially satisfied but not enough to be deemed substantially in compliance.	0
<b>Not Yet Required</b>	no action is required of the Landfill owner/operator until such time that circumstances or events occur that are specified in the condition of approval (e.g. upon request by the County). Explanation is provided in the adjoining Comments column.	23
<b>Objective</b>	objectives which are intended to be achieved by complying with the conditions in that section.	13

**288**

<b>Highlighted Condition #</b>	condition #s highlighted in yellow were either added or modified as a result of the first Permit Review in 2014-15.
Notes in <b>bold text</b>	<b>bolded text</b> in the Notes column reflects <b>UPDATES</b> provided for this second Permit Review in 2016.

**EXHIBIT D - Compliance Status Table: Keller Canyon Landfill Land Use Permit 2020-89 Conditions of Approval**

Condition	Condition Description	Compliance Status	Comments
1.1	<b>Short Title.</b> The Keller Canyon Landfill project is henceforth referred to in this document as the Landfill.	Informational	Condition Acknowledged.
2.1	<b>Ultimate Responsibility.</b> The conditions of approval identify the Landfill developer as the party responsible for implementing conditions involving construction and improvements, and the Landfill operator for implementing conditions involving maintenance and management. Regardless of these identifications, the Landfill owner shall be responsible for complying with all conditions.	Informational	Condition Acknowledged.
2.2	<b>Transfer of Ownership.</b> The Land Use Permit for the Landfill shall run with the land; however, a new owner shall be responsible for notifying the County Conservation and Development Department of any change in ownership. A change in ownership shall be interpreted to mean the acquisition of 5 percent or more of the value of the Landfill site covered by this Land Use Permit. (It is noted that other permits may not necessarily run with the land.)	Completed. On-Going	The First Amended Landfill Franchise Agreement contains assignment requirements pertinent to a change in ownership. The Keller Canyon Landfill Company (KCLC) was owned by Browning Ferris Industries (BFI) at the time the Landfill began operations in 1992. In 1999, BFI sold/transferred KCLC and other local assets to Allied Waste Industries. In 2008, Allied Waste Industries merged with Republic Services, Inc.
2.3	<p><b>Assignment of Responsibility.</b></p> <p>a) The Board may assign the responsibility of administering specific Conditions of Approval or provisions of this LUP, such as State Minimum Standards, to County Departments or other units of government.</p> <p>b) The Board may suspend the implementation of conditions or provisions of this LUP where such conditions or provisions are inconsistent with the terms of a contract or agreement entered into between the Board and the operator or other units of government, or by the terms of a joint powers agreement where the County is a member of the joint powers agency. This would not alleviate the need to comply with the public approval process required when amending this LUP. Any Board approved suspension would automatically be nullified at such time as the contract or agreement no longer includes terms inconsistent with the specified condition.</p> <p>c) For the purposes of Condition 2.3(b), the Franchise Agreement between the County and the Landfill Owner as amended in November 1994, is an eligible contract.</p> <p>d) If no contract or agreement is in force, as referred to in Condition 2.3(b), the County retains authority to implement this LUP and all of its Conditions.</p>	Informational	<b>This is a new condition approved by the Board of Supervisors in conjunction with the Permit Review for County File LP2020-89 on September 22, 2015.</b>
3.1	<b>Compliance Objective.</b> The Landfill developer and operator shall at all times comply with the requirements of laws and permits applicable to the facility. This condition is not intended to grant authority or assign responsibility to the County for the independent enforcement of regulatory and permitting requirements that fall within the primary jurisdiction of other agencies (see Condition 11.11).	In Compliance. On-Going	Operation has generally been conducted in compliance with all local, State, and federal laws and regulations. The Department of Conservation and Development (DCD) is not aware of any violations that were not corrected in a timely manner. The Landfill operator and any Vendors/operators subcontracted to work at KCL is required to comply with this LUP and all other permits with regulatory authority over landfill operations. See Condition 14.2 for a listing of approved permits.

**EXHIBIT D - Compliance Status Table: Keller Canyon Landfill Land Use Permit 2020-89 Conditions of Approval**

Condition	Condition Description	Compliance Status	Comments
3.2	<b>Design Standard.</b> The Landfill developer shall design the Landfill facility to meet the requirements of the San Francisco Regional Water Quality Control Board for a Class II waste disposal facility.	In Compliance. On-Going	KCL is a Class II waste disposal facility that has been classified by the Regional Water Quality Control Board (RWQCB) according to the provisions of Title 27, Environmental Protection--Division 2, Solid Waste Chapter 3. Criteria for All Waste Management Units, Facilities, and Disposal Sites . Keller Canyon Landfill's design, construction, and operation comply with all State Minimum Standards for solid waste handling and disposal specified in Title 27 of the California Code of Regulations (CCR). The design for each phase of the landfill is subject to RWQCB review and approval prior to construction being authorized by DCD.
3.3	<b>State Minimum Standards.</b> The operation and maintenance of this facility shall at all times comply with Minimum Standards for Solid Waste Handling and Disposal (California Code of Regulations, Title 14 and Title 27).	In Compliance. On-Going	In 1997, California Code of Regulations (CCR) Title 14 and 23 for the Solid Waste Facilities Permit, were modified into CCR Title 27. KCL complies with all Minimum Standards for Solid Waste Handling and Disposal. The LEA has local enforcement authority over KCL and conducts monthly inspections of the landfill site to ensure compliance with the Minimum Standards for Solid Waste Handling and Disposal. See Condition 3.10.
3.4	<b>Land Use Permits.</b> The Landfill developer and operator shall at all times comply with the provisions and requirements of this Land Use Permit. A violation of any of these conditions may be cause for revocation of the Land Use Permit pursuant to County Code Section 418-4.020 following reasonable written notice. Alternatively, the County has the option of issuing formal notices and assessing penalties pursuant to Section 4.19 of the Landfill Franchise Agreement or County Code Chapter 14-6, Civil Enforcement.	In Compliance. On-Going	Landfill owner/operator is in compliance with the vast majority of LUP conditions of approval currently in effect. This table reflects DCD staff's assessment of landfill operator's current status of compliance for each LUP Condition of Approval.
3.5	<b>Solid Waste Facilities Permit.</b> The Landfill operator shall conform with all provisions and requirements of the Landfill's Solid Waste Facilities Permit, and any related directives of the California Department of Resources Recycling and Recovery (CalRecycle) or Contra Costa Environmental Health, as the Local Enforcement Agency for CalRecycle.	In Compliance. On-Going	<p><b>UPDATE: The Solid Waste Facility Permit was reviewed by Contra Costa Environmental Health in 2014. The next permit review is scheduled for 2019. CalRecycle conducted unannounced inspections in October and November of 2014. CalRecycle returned in November to focus on the receipt of the curbside collected residential green waste materials and the deployment of the ADC at the end of operating day. CalRecycle staff observed employees removing contaminants at the active face (plastic containers and bags, plastic buckets, cardboard and larger tree branches) from the received piles. The site operator explained that due to the location of the work face (tight corner fill), they were not able to spread the pile for the employees in order to remove contaminants that may be hidden inside the material pile. The observation that contaminants were not removed prior to placement of the ADC material at the active face is inconsistent with the ADC protocols approved by the LEA and described in its letter dated February 24, 1999. This practice is also not allowed under 27 CCR 20690, as material must be processed before application of the ADC to the active face. The RDSI requirements for ADC have changed since the 2002 RFI Amendment. The RDSI does not adequately fulfill the current regulation requirements. The RDSI needs to be amended to describe the operations observed at the landfill in October 2014. Tile 27 CCR 21600 (b)(6)(B) requires that specific information be described which are currently not in the governing RDSI. Specifically, the RDSI contains no information regarding processing methods for curbside collected residential green waste material to remove contaminants and material larger than 4 feet and 3 inches in diameter and the methods for the application of the material over the daily compacted refuse or other specification as approved by the LEA during the demonstration project. An RDSI Amendment was approved in late 2014 and in 2015 in response to an appeal, the RDSI amendment approval was upheld by CalRecycle.</b></p> <p>The landfill operator submitted a Report of Disposal Site Information (RDSI) and formal application for a Solid Waste Facility Permit (SWFP) on 1/3/1992 (see letter from S. Gordon (KCLC) to C. Nicholson (HSD), dated 1/3/1992. SWFP 07-AA-0032 was issued April 29, 1992, and is reviewed every five years. <b>The last revision was in 2014.</b> The LEA conducts monthly inspections.</p>

**EXHIBIT D - Compliance Status Table: Keller Canyon Landfill Land Use Permit 2020-89 Conditions of Approval**

Condition	Condition Description	Compliance Status	Comments
3.6	<b>Class II Landfill Requirements.</b> The Landfill operator shall at all times comply with the Class II waste disposal facility provisions and requirements of Article 3, Chapter 15 of Title 23 and Title 27 of the California Code of Regulations.	In Compliance. On-Going	In 1997, California Code of Regulations (CCR) Title 14 and 23 for the Solid Waste Facilities Permit, were modified into CCR Title 27. Title 27 allows for preparation of a <i>Joint Technical Document (JTD)</i> to include the Report of Disposal Site Information (RDSI), Report on Waste Discharge, Preliminary Closure Plan, and Postclosure Maintenance Plan. These documents formerly were submitted separately.
3.7	<b>Other Regulatory Agencies' Requirements.</b> The Landfill operator shall at all times comply with the provisions and requirements of other regulatory agencies having jurisdiction over the facility.	In Compliance. On-Going	The landfill operator has generally been in compliance with all facility permits. There is no history or evidence of on-going non-compliance with other permits of other agencies with regulatory jurisdiction over landfill design and operations.
3.8	<b>Utilities, Service Districts, and Government Agencies' Requirements.</b> The Landfill developer or operator shall at all times comply with the regulations and requirements of utilities, districts, or agencies which have jurisdiction over the installation of improvements or provide services to the landfill.	In Compliance. On-Going	<b>UPDATE: There were no recorded permit violations in 2015 and 2016 to-date. The Landfill Operator is in compliance with all facility permits.</b>
3.9	<b>Notice Coordination.</b> The Landfill operator shall notify the Department of Conservation and Development (DCD) in writing at the time any report is submitted to other agencies concerning the design, operation, and maintenance of the Landfill. Copies shall be made available or mailed to DCD offices at 30 Muir Road in Martinez upon request.	In Compliance. On-Going	<b>UPDATE: All of the reports submitted to agencies in 2015 and 2016 (to date) have been sent to DCD either electronically or in hardcopy form.</b>  Original compliance with this condition was approved by CDD on 10/15/1991. See Community Development Department Memo, V. Conklin to C. Zahn, dated 10/15/1991, and as updated through 10/25/1991.  Copies of all reports concerning landfill design, construction, operation, and maintenance that are submitted to other agencies are available upon request. Reports submitted to some agencies are available on-line (e.g. RWQCB – Geotracker).
3.10	<b>Monitoring and Inspection.</b> All monitoring reports and results of inspection or analysis shall be made available to the Contra Costa Environmental Health and Conservation and Development Departments. Any indication of an emergency or other serious problem relating to public health and safety shall be reported at once.	In Compliance. On-Going	The landfill operator coordinates with both CCEH and DCD in reporting any potential problems relating to public health and safety. All monitoring and inspection reports are on-file at the Landfill owner/operator's office and available for review by interested agencies during normal business hours. Inspection reports produced by County Environmental Health and CalRecycle are posted and available on-line.  Contra Costa Environmental Health operates as the solid waste Local Enforcement Agency (LEA) for the California Department of Resources Recycling and Recovery (CalRecycle) with the primary responsibility to ensure correct operation and closure of solid waste facilities in the State of California, including the proper storage and transportation of solid wastes. The LEA enforces SWFP #07-AA-0032 for Keller Canyon Landfill. Also see comments in condition of approval 14.2.

**EXHIBIT D - Compliance Status Table: Keller Canyon Landfill Land Use Permit 2020-89 Conditions of Approval**

Condition	Condition Description	Compliance Status	Comments
3.1.1	<p><b>Master Chart.</b> The Landfill operator will maintain for reference a master chart showing schedules and results of preparation, operation, monitoring and reporting in all major phases of the facility.</p>	Completed. On-Going	<p>An initial Master Chart was approved by CDD in 1991. An update of the original development plan for the landfill prepared in 1991 was necessitated by changes that occurred from landfill operations and site development. A Conceptual Master Plan for the landfill was submitted to CDD in July 2002. The Master Plan was comprehensive and addressed important aspects of landfill design and operation. The Master Plan also demonstrated that the original permitted air space volume of 75 million cubic yards was maintained after landslide repairs and other site development.</p> <p>Landfill development sequencing for the remaining lifespan of the landfill was prepared consisting of eight (8) groupings of phases. The phases within the first two groupings, collectively known as Phases 1 and 2 respectively, had all been completed by 2002. Currently the Phase 3 is being implemented. A revised development plan for the remaining undeveloped portions of the landfill was presented in Figure 8 of the Master Plan. The revised plan accounts for mitigation of landslides, stability of containment systems and waste mass, and other design and operations parameters required to meet regulatory requirements.</p> <p>Over time, a Master Chart as described in this condition has been superseded by modern computerized project management systems. Similar information is already conveyed in periodic reports on landfill activities and site development that are submitted to regional/state agencies (copies provided to the County and also available for review during normal business hours).</p> <p>See Community Development Department Memo, V. Conklin to C. Zahn, dated 10/15/1991, and as updated through 10/25/1991.</p>
4.1	<p><b>Validity Period.</b> The Landfill developer shall install pre-requisite improvements and open the Landfill for receiving refuse within three years of the final approval of the project's Solid Waste Facilities Permit. This validity period shall be tolled while any appeal filed by parties other than the Landfill developer is pending. The Landfill developer may request from the Director of Community Development one or more one-year extensions of the Land Use Permit. If the Land Use Permit is not implemented within the specified time, it shall become null and void. The Director of Community Development may allow each one-year extension if the Director finds that there are changed circumstances which warrant the consideration of changes to the Conditions of Approval.</p>	Completed	<p>The Contra Costa County Board of Supervisors approved LUP 2020-89 on July 24, 1990.</p> <p>The Solid Waste Facility Permit was issued on April 29, 1992. KCL became operational on May 7, 1992, within the specified time period of this condition.</p>
4.2	<p><b>Operative Date.</b> This Land Use Permit is valid upon approval by the Board of Supervisors. However, it shall not become operative until and unless the permittee (landfill owner, etc.) first obtains and the Board of Supervisors grants a franchise to or approves an agreement with permittee (see Section 13, Franchise Agreements).</p>	Completed	<p>The original Franchise Agreement was issued on December 4, 1990. The Franchise Agreement was amended on September 13, 1994 as the First Amended Landfill Franchise Agreement. Amendment No. 1 to the First Amended Franchise Agreement was executed on November 1, 1994. Amendment No. 2 to the First Amended Franchise Agreement was executed on February 27, 1996.</p>
5.1	<p><b>Area of Origin.</b> The Landfill operator shall not refuse to receive eligible wastes or cover materials which originate in Contra Costa County provided such wastes or materials are delivered to the facility in accordance with these Conditions of Approval and the landfill's Solid Waste Facilities Permit, and provided that the required governmental fees are paid. Rate setting requirements are specified in the Landfill Franchise Agreement and Section 12 of this Land Use Permit.</p>	No Longer Applicable	<p>Judicial and legislative decisions have since overturned restrictions on disposal in local landfills to protect from too early filling. Waste origin restrictions were also nullified through the First Amended Franchise Agreement in 1994. The Board of Supervisors authorized KCL to accept certain special handling wastes (non-hazardous and non-toxic) originating outside of Contra Costa County pursuant to guidelines for direct haul originally approved by the Board on 10/27/1992. See report to the Board of Supervisors dated December 7, 1993 and approved on December 14, 1993.</p>

**EXHIBIT D - Compliance Status Table: Keller Canyon Landfill Land Use Permit 2020-89 Conditions of Approval**

Condition	Condition Description	Compliance Status	Comments
5.2	<b>Out-of-County Wastes.</b> <i>INVALIDATED BY LEGISLATURE</i>	No Longer Applicable	The prohibition on import of waste from outside the County was rendered No Longer Applicable by U.S. Supreme Court decisions in June 1992 that reinforced that solid waste is a business commodity subject to federal commerce clause protection.
5.3	<b>Sub-County Service Area.</b> If there is more than one Class II or Class III landfills operating in Contra Costa County, the Board of Supervisors may establish sub-County service areas for each on a temporary or long-term basis. If the Board has established a sub-County service area for the Landfill, the operator shall not accept waste for disposal from outside such area.	Not Yet Required	Sub-County service areas have not been established.
5.4	<b>Reciprocal Capacity Agreement.</b> The Landfill operator shall receive waste from outside Contra Costa County if in accordance with the terms and conditions of a Reciprocal Capacity Agreement entered into by Contra Costa County with another county. Waste shall be received upon reasonable notice to the Landfill operator and the Board of Supervisors and direction by the Board to the Landfill operator as to the terms and conditions under which the waste will be received. The Board may specify disposal charges which are applicable only to the waste received under the Reciprocal Capacity Agreement.	Not Yet Required	Reciprocal Capacity Agreements with other jurisdictions have not been established.
5.5	<b>Pre-Requisite Curbside Recycling Program.</b> The Landfill shall not admit for disposal waste loads from communities which do not have an eligible curbside recycling or equivalent program as determined by the Department of Conservation and Development. An eligible program shall recover a range of recyclable materials consistent with a curbside recycling program operating pursuant to a Board of Supervisors approved franchise agreement. The Board of Supervisors has the discretion to identify additional factors to be considered when determining eligibility. The Board retains the authority to approve community programs previously deemed to be ineligible by the Department of Conservation and Development.	In Compliance. On-Going	<p><b>UPDATE: A recent review by the landfill operator of waste accepted by origin in 2015 revealed that all but one of the jurisdictions had an acceptable curbside recycling program, either certified in the CalRecycle database or verified by jurisdiction. Staff reviewed disposal reporting data that revealed 99.972% of the disposed tonnage came from jurisdictions within the Bay Area. Bay Area cities and municipalities have well established curbside recycling programs in place. KCL only accepted one load of contaminated soil from the singular jurisdiction that did not appear to have a fully acceptable curbside recycling program.</b></p> <p>The landfill operator uses CalRecycle's database of certified curbside recycling programs as a means of determining if a community has curbside recycling in place. Operator intends to institute a pre-acceptance procedure to ensure verification of curbside recycling occurs prior to loads being accepted from new jurisdiction.</p>
6.1	<b>Eligible Wastes.</b> The Landfill operator shall allow only wastes eligible for disposal in a Class II facility, as defined by the Regional Water Quality Control Board to be admitted to the land-fill. The wastes admitted to the landfill shall also be consistent with the Solid Waste Facilities Permit (07-AA-0032), administered by Contra Costa Environmental Health, and consistent with the 1990 Environmental Impact Report and Board of Supervisors' policies and approvals (including the Board of Supervisors conditional authorization in 1992-93 to accept special wastes and limited direct haul – see Conditions 8.5 through 8.7) and these conditions of approval. To the extent allowed by law, the Board of Supervisors may direct the Landfill operator not to accept wastes that do not meet State and County policies and regulations.	In Compliance. On-Going	<p><b>UPDATE: No ineligible waste was accepted in 2015 or early 2016.</b></p> <p>Signage is posted at the gate and scale house outlining all prohibited material.</p>



**EXHIBIT D - Compliance Status Table: Keller Canyon Landfill Land Use Permit 2020-89 Conditions of Approval**

Condition	Condition Description	Compliance Status	Comments
6.2	<p><b>Designated Wastes.</b> The Landfill operator shall allow only those designated wastes (as defined in Section 20210 of Title 27, of the California Code of Regulations and Section 13173 of the California Water Code) approved for this facility by the San Francisco Regional Water Quality Control Board, and shall be consistent with the waste types allowed for disposal pursuant to Condition 6.1. The Board of Supervisors may designate special rates for this waste to the extent allowed pursuant to the terms of the Landfill Franchise Agreement.</p>	In Compliance. On-Going	Facility is in compliance with regulations in Title 27 of the CCR and conditions related designated wastes. On December 14, 1993, the Board of Supervisors authorized KCL to accept certain designated wastes (special handling wastes, that are non-hazardous and non-toxic) originating outside of Contra Costa County, subject to specific conditions related to volume limitations, rates, waste inspection, and laboratory testing among others. See Recommendation from Val Alexeeff, GMEDA Director, to the Board of Supervisors dated December 7, 1993. The Board approved as recommended on December 14, 1993. Many of these designated wastes have since been incorporated into the SWFP as described in Condition 6.1 Eligible Wastes above.
6.3	<p><b>Infectious Wastes.</b> The Landfill operator shall accept only those infectious wastes identified in, and disposed of in accordance with the Solid Waste Facilities Permit.</p>	In Compliance. On-Going	All potentially infectious waste are disposed of in accordance with Section 14 Prohibitions of the SWFP.
6.4	<p><b>Ineligible Wastes.</b> The Landfill operator shall not allow the following wastes to be disposed at the landfill:</p> <ul style="list-style-type: none"> <li>a) Hazardous or toxic wastes.</li> <li>b) Radioactive wastes.</li> <li>c) Liquid wastes, other than utility sludges meeting Regional Water Quality Control Board requirements.</li> <li>d) Other ineligible wastes specified in the Solid Waste Facilities permit administered by the Contra Costa Environmental Health.</li> </ul>	In Compliance. On-Going	<p><b>UPDATE: No ineligible wastes were accepted at the landfill since the last permit review.</b></p> <p>All incoming loads are routinely screened in accordance with the most recent Load Check Program (updated in September 2013) and Condition 17j (Hazardous Waste Screening) of the SWFP. See Condition 6.1 &amp; 7.1.</p>
6.5	<p><b>Emergency Use.</b> If the service area of the Landfill is determined to be a sub-area of the County, the County Department of Conservation and Development or Contra Costa Environmental Health may allow legal waste originating in areas of Contra Costa County, other than those stipulated in Section 5, to have access to the landfill for periods up to 180 days on an emergency basis. The department(s) may grant one extension for no longer than 180 days. The Board of Supervisors may allow the emergency use of the landfill to continue for any time period deemed necessary.</p>	Not Yet Required	Sub-County service areas have not been established.
6.6	<p><b>Hazardous Waste Screening and Management.</b> See Section 19.</p>	Informational	This condition cross-references to another LUP condition.
6.7	<p><b>Area of Origin Restrictions.</b> See Section 5.</p>	Informational	This condition cross-references to another LUP condition.

Condition	Condition Description	Compliance Status	Comments
7.1	<p><b>Eligible Vehicles and Loads.</b> The Landfill operator shall screen loads to limit to the extent practicable the intake of ineligible waste. Prior to receiving waste, the Landfill operator shall prepare in writing a program for identifying eligible vehicles and screening loads at the Landfill entrance, random sampling and inspection for ineligible wastes, and checking loads at the Landfill disposal area. The Load Inspection program shall include inspection for hazardous wastes and procedures for their handling and off-site disposal consistent with the Contra Costa County Hazardous Waste Management Plan. The program shall be subject to the approval of Contra Costa Environmental Health and the County Conservation and Development Department.</p>	In Compliance. On-Going	<p><b>UPDATE: CCEH reviewed and approved the Load Check Program as part of the LEA's 2014 review of the RDSI. DCD received and reviewed the Program and no deficiencies were identified, formal approval is still pending.</b></p> <p>The Eligible Vehicles and Loads Program was developed to conform with the requirements of 27 CCR, Section 20870, and the WDRs [Wastes and Their Classification (Part 11)] for KCL. The Eligible Vehicles and Loads program is designed to identify and remove hazardous and prohibited wastes from the waste stream coming to the landfill. Incoming wastes are verified based on visual inspection, questioning by staff, physical assessment, and waste characterization analysis. If an incoming load is suspected of containing ineligible waste, based on the visual inspection, the hauler will be questioned by landfill personnel about the contents of the load. If there is still a question about the acceptability of the waste, the hauler will not be permitted to unload the waste.</p> <p>The original Load Check Program, dated April 25, 1993 was approved by the Health Services Department and CIWMB as part of the RDSI pursuant to issuance of the SWFP. The Load Check Program was revised in September 2013. Condition 17j (Hazardous Waste Screening) of the SWFP specifies procedures for hazardous waste inspection. Landfill personnel are trained in the implementation of identifying non-eligible vehicles and ineligible waste. Ineligible hazardous waste materials are not accepted at the landfill per conditions in this LUP and the SWFP. A Health Services Department Memo from C. Nicholson to C. Zahn (CDD) dated 3/10/1992, states this condition was reviewed and certified.</p> <p>Also see Condition 19.4.</p>
7.2	<p><b>Load Covering.</b> The Landfill operator shall spot check all incoming waste-hauling vehicles for proper covering or containerization consistent with the requirements of Section 418-2.008(a) of the County Code. The operator shall identify any waste loads which are susceptible to littering or leakage because of the lack of covering, inadequate covering, or disrepair of screens, covers or containers. Customers delivering any such waste loads shall be required to provide evidence that corrective actions have been taken to effectively cover and contain waste loads (e.g. waste adequately secured with covers and containers in good repair) in order to be eligible to deliver waste loads in the future. Landfill operator shall track and report applicable details about the occurrences and corrective actions taken to the County Department of Conservation and Development annually.</p>	In Compliance. On-Going	<p><b>UPDATE: Republic Services removed the "How's My Driving?" stickers from their trucks and replaced them with "Together for Safer Roads" stickers. Incidents of litter bounce out from Republic trucks can still be recorded using the truck number which identifies every truck, and using the local phone number printed on all trucks. Republic Services is a member of Together for Safer Roads, an organization made up of private sector companies dedicated to improving traffic safety on the nation's roads. Republic is implementing a program of Best Practices for its fleet of vehicles related to road safety management, safer roads and mobility, safer vehicles, and safer road users. Republic trucks and trailers are numbered. Complainants must call Keller directly to report concerns.</b></p> <p>Every incoming load is inspected to ensure all waste-hauling vehicles are covered; waste loads are screened for excessive littering and inadequate covering. Transfer vehicles with inadequate screens or containers are repaired as they are identified. Republic's trucks <b>should</b> have phone number for others to call if litter is observed so corrective actions are taken in a timely manner (like "How's my driving"). Also see Condition 25.3.</p> <p>On May 14, 1991, the Board of Supervisors amended County Ordinance Code 91-26 (Requirements for Vehicles Transporting Refuse <b>codified as Chapter 418-2</b>) to require all waste-carrying vehicles transporting refuse to solid waste facilities in the County to have their loads covered. On September 9, 1991 the Board of Supervisors approved additional recommendations that included but was not limited to requiring <b>DCD</b> to include off-site litter policing in new permits for waste disposal and processing facilities; and directed County staff to work with the Sheriff's Department and California Highway Patrol to assure enforcement of covered load and anti-littering requirements.</p>

**EXHIBIT D - Compliance Status Table: Keller Canyon Landfill Land Use Permit 2020-89 Conditions of Approval**

Condition	Condition Description	Compliance Status	Comments
8.1	<p><b>Eligible Vehicles.</b> The Landfill operator shall admit only the following refuse transport vehicles:</p> <ul style="list-style-type: none"> <li>a) Transfer station trucks (vans). Transfer stations shall have a Waste Management Program, which includes hazardous waste screening and resource recovery operations. Program may be subject to the approval of the Board of Supervisors if deemed necessary for consistency with the Countywide Integrated Waste Management Plan.</li> <li>b) Demolition and construction material trucks hauling debris that would not be recycled or otherwise diverted from disposal if processed at a local Transfer Station. There are waste reduction requirements that apply to such wastes generated by businesses and industries, therefore the operator shall assist the County to help ensure compliance with such requirements or goals through implementation and compliance with Conditions 8.5 – 8.7.</li> <li>c) Incinerated sewage sludge-hauling trucks originating at utilities.</li> <li>d) Sewage and water treatment plant sludge and other byproduct trucks with loads complying with San Francisco Regional Water Quality Control Boards solids-to-liquid requirements.</li> <li>e) Trucks hauling Designated Wastes approved for this landfill by the Regional Water Quality Control Board.</li> <li>f) Other specialized waste transport trucks, hauling wastes identified in the Landfill's Solid Waste Facilities Permit which cannot be feasibly processed to increase diversion through a Transfer Station.</li> </ul>	In Compliance. On-Going	Only eligible vehicles, as outlined in this condition and/or the operating permits, are allowed admittance into the Keller Canyon Landfill. In-county waste origin requirements of this condition are unenforceable as a result of U.S. Supreme Court decisions in June 1992 (see also the First Amended Franchise Agreement in 1994). See Condition 5.1.
8.2	<b>Service Area Restriction.</b> See Section 5.	Cross-Reference	This condition solely cross-references another LUP section. See Section 5.
8.3	<b>Emergency Exemption.</b> See Condition 6.5.	Cross-Reference	This condition solely cross-references another LUP condition. See Condition 6.5.
8.4	<b>Reciprocal Use Exemption.</b> See Condition 5.4	Cross-Reference	This condition solely cross-references another LUP condition. See Condition 5.4.
8.5	<p><b>Direct Haul.</b> Only wastes in the prescribed vehicles which would not be recycled or otherwise diverted from disposal if processed through a local transfer station may be considered for direct haul pursuant to the Procedures specified in Condition 8.6. At least once per year, the Landfill operator shall submit an updated list of waste and material types recovered prior to transfer for disposal at the landfill if contained in loads delivered to any of the local transfer stations open to the public. The annual list shall be subject to the review and approval of the Department of Conservation and Development and is intended to be used when screening direct haul eligibility pursuant to Condition 8.6(g). Loads containing materials that will be used as cover or otherwise beneficially reused on-site and treated as diversion under the Integrated Waste Management Act may be direct hauled without going through a transfer station.</p>	Not Yet Required	<p><b>UPDATE: New Conditions 8.5 – 8.8 pertaining to direct haul take effect 18 months from September 22, 2015 approval by the County Board of Supervisors as part of the initial KCL Permit Review conducted in 2014/15.</b></p>

**EXHIBIT D - Compliance Status Table: Keller Canyon Landfill Land Use Permit 2020-89 Conditions of Approval**

Condition	Condition Description	Compliance Status	Comments
8.6	<p><b>Direct Haul Procedures.</b> Direct haul process and materials shall be consistent with the Solid Waste Facility Permit (No. 07-AA-0032), this LUP, and applicable policies adopted by the Board of Supervisors including those identified in 8.6(k) below. The operator shall ensure new customers receive information consistent with i) and j) prior to gaining access to the site. The operator shall conduct screening procedures specified in a) through h) prior to allowing customers to direct haul waste/material loads to the landfill. Operator shall provide written confirmation that eligibility has been demonstrated consistent with these procedures prior to loads being accepted for disposal. Operator shall summarize results of direct haul eligibility screening completed each quarter in the direct haul reports required under Condition 8.7.</p> <p>a) Name of company and physical location at which the waste or material was generated.</p> <p>b) Complete description of waste including chemical analysis and solids-to-liquid ratio when appropriate.</p> <p>c) Description of originator’s in-house waste inspection program(s) to ensure screening for hazardous and/or toxic materials or originator’s written confirmation that their practices comply with uniform waste inspection program prepared by the Landfill operator.</p> <p>d) Description of volume and expected frequency of waste to be hauled and a description of the specialized waste transport vehicle(s) to be utilized.</p> <p>e) Description of the waste originator’s in-house waste reduction and recycling program(s) or originator’s written confirmation that their practices comply with a uniform waste reduction and recycling plan to be prepared by Landfill operator and approved by the Department of Conservation and Development.</p> <p>f) Originator’s or transporter’s affirmation to adhere to County imposed haul route and peak hour hauling restrictions.</p> <p>g) Written confirmation by the Landfill operator that the waste or material is not on the approved annual list described in condition 8.5, and</p> <p>h) Written waste eligibility determination from Keller Canyon Landfill Company based on a) through g) above.</p> <p>i) Requirements of Keller Canyon Landfill Company describing contract for landfill use, rules and regulations of the landfill (e.g. on-site speed limit), prescribed haul route, load inspection program, driver training program, and any other such information as required.</p> <p>j) Requirements for proper load covering or containerization and consequences for non-compliance specified in Condition 7.2.</p> <p>k) Any other information required by the Director of Conservation and Development, or by the actions of the Board on August 11, 1992 October 27, 1992, November 24, 1992, August 17, 1993 and December 14, 1993.</p>	Not Yet Required	<p><b>UPDATE: New Conditions 8.5 – 8.8 pertaining to direct haul take effect 18 months from September 22, 2015 approval by the County Board of Supervisors as part of the intial KCL Permit Review conducted in 2014/15.</b></p>
8.7	<p><b>Direct Haul Reports.</b> The Landfill operator shall submit quarterly direct haul reports to the Department of Conservation and Development. The quarterly reports shall contain details about all direct haul loads, including the date accepted, customer (company) name, waste type, tonnage, location and jurisdiction of waste/material origin (city and county) and end use (disposal, cover or other on-site beneficial reuse). Summarized results of all direct haul eligibility screening conducted during each period shall be submitted in conjunction with the quarterly waste origin reports. The quarterly reports shall also identify the total tonnage of municipal solid waste (Class III waste) received that quarter, total tonnage of Class II wastes received that quarter, and the percentage of total waste received which is characterized as Class II. If determined necessary by DCD, additional reporting information or more frequent reporting may be required in the future.</p>	Not Yet Required	<p><b>UPDATE: New Conditions 8.5 – 8.8 pertaining to direct haul take effect 18 months from September 22, 2015 approval by the County Board of Supervisors as part of the intial KCL Permit Review conducted in 2014/15.</b></p>

**EXHIBIT D - Compliance Status Table: Keller Canyon Landfill Land Use Permit 2020-89 Conditions of Approval**

Condition	Condition Description	Compliance Status	Comments
8.8	<p><b>Emergency Direct Haul.</b> In the event that a natural disaster or other emergency prevents the timely processing of wastes through a transfer station before disposal at the landfill, such waste or loads may be considered for direct haul. The landfill operator shall submit a written request to the County Department of Conservation and Development when circumstances or conditions warrant, or may warrant, emergency direct haul to the landfill. The landfill operator shall not proceed with emergency direct haul until written approval has been provided by the Director of the Department of Conservation and Development. The landfill operator shall submit an incident report describing the basis for emergency direct haul and the contingency actions taken.</p>	Not Yet Required	<p><b>UPDATE: New Conditions 8.5 – 8.8 pertaining to direct haul take effect 18 months from September 22, 2015 approval by the County Board of Supervisors as part of the initial KCL Permit Review conducted in 2014/15.</b></p>
9.1	<p><b>Hours of Operation.</b> The Landfill operator shall not open the landfill to receive waste loads before 7:00 a.m. or after 7:00 p.m. Refuse shall be covered by 7:30 p.m. at which time working lights shall be extinguished. Entry and security lights shall be dimmed at 7:30 p.m. Other hours of operation, within those parameters, may be specified by Contra Costa Environmental Health or in the Landfill's Solid Waste Facilities Permit. Special loads may be received at other times in accordance with procedures established by Contra Costa Environmental Health or the Department of Conservation &amp; Development.</p> <p>The Director of Conservation and Development may administratively shorten or extend the hours of operations prescribed above after consultation with the Landfill operator, Contra Costa Environmental Health, and the City of Pittsburg, after holding a public hearing to obtain the comments of other interested parties. To shorten the hours of operation, the Director of Conservation and Development shall find that the changes are needed to mitigate substantial noise, traffic, or similar impacts arising from the operation of the Landfill which were not known when this Land Use Permit was adopted. To extend the hours of operation, the Director of Conservation and Development shall find that longer hours will not cause traffic, noise, glare, or similar impacts of Landfill operations to substantially increase in the vicinity of the Landfill. Exceptions to this limitation may be granted in response to natural disasters or other emergencies if deemed warranted by the Director of Conservation and Development if required to address any applicable officially declared disaster.</p>	In Compliance. On-Going	<p>Hours of operation and control of on-site lighting are in compliance as specified in this condition. There have been no shortening of hours due to unforeseen impacts arising after the LUP was issued. No waste is accepted after 7:00 P.M. The required daily cover is completed by 7:30 P.M. All stationary lights are extinguished by 7:30 P.M.</p>
9.2	<p><b>Operating Days.</b> The landfill shall remain open for operation six days a week except on Holidays. It shall close on Sundays. Exceptions to this limitation may be granted in response to natural disasters or other emergencies if deemed warranted by the Director of Conservation and Development.</p>	In Compliance. On-Going	<p>The facility is open six days a week and closed on Sundays as specified in this LUP condition; Specification 5b. of the SWFP; and Condition #17309 part 1 of the Major Facility Review permit issued by the BAAQMD.</p>
9.3	<p><b>Maximum Daily Tonnage.</b> The landfill may accept for disposal a maximum of 3,500 tons of refuse per day. The Board of Supervisors shall review and revise, if necessary, the maximum allowable tonnages per day. If the Board establishes sub-County service areas, maximum tonnages for each landfill may be prorated to reflect their service areas. The Board may increase the maximum daily tonnages, if necessary, to reflect Reciprocal Capacity Agreements or emergency measures. Exceptions to this limitation may be granted in response to natural disasters or other emergencies if deemed warranted by the Director of Conservation and Development. The Landfill operator shall submit quarterly reports to the Department of Conservation and Development solely showing daily waste tonnage accepted for disposal.</p>	In Compliance. On-Going	<p><b>UPDATE: The maximum daily tonnage limit of 3,500 was not exceeded in 2015 or 2016 to-date.</b></p> <p>KCL is in compliance with the maximum daily tonnage limit of 3,500 specified in this LUP condition; Section 5c and Condition 17m of the SWFP; and Condition #17309 part 2(a) of the Major Facility Review permit issued by the BAAQMD. Tonnage records are submitted to County DCD and CCEH and are available for review. Sub-County services areas have not been established.</p>

**EXHIBIT D - Compliance Status Table: Keller Canyon Landfill Land Use Permit 2020-89 Conditions of Approval**

Condition	Condition Description	Compliance Status	Comments
9.4	<b>Minimum Buffer Zone.</b> The Landfill developer shall reserve a minimum buffer of 2,000 feet from the closest place of permanent waste placement to the closest existing residence on Jacqueline Drive.	In Compliance. On-Going	The Minimum Buffer Zone of 2,000 feet was established and is maintained per this condition.
9.5	<b>Special Buffer Area.</b> No residential housing shall be permitted at any time in the special buffer area. See Condition 23.2.	In Compliance. On-Going	The Special Buffer Area continues to be under Williamson Act contract (Contra Costa County, 2008) and is zoned A-4, Agricultural Preserve.  No residential housing has been constructed in the Special Buffer Area. Application submitted for oil and gas well permit to drill a well in the Special Buffer Area (094-360-010) in June 2003.
9.6	<p><b>Dedication of Special Buffer Area.</b> At the time of the submission of the landfill's Development and Improvement Plan, pursuant to Government Code Section 7050, the landfill owner shall offer to dedicate the fee title of the land within the Special Buffer Area to the County of Contra Costa for recordation. The County may accept the fee title and complete the dedication subsequent to the opening of the landfill for the disposal of waste. In making the offer of dedication the Landfill owner may reserve the rights to carry out mitigation programs required by these Land Use Permit Conditions of Approval, and as may be further detailed in implementation plans required to be prepared by these Conditions within the Special Buffer Area.</p> <p>The Landfill operator may perform grading and make installations, such as drainage ditches within the Special Buffer Area related to the landfill facility, provided that the grading and installations are consistent with the approved final Development and Improvements Plan and do not impair the capability of the Area to accommodate agricultural grazing and provide habitat mitigation consistent with these Conditions of Approval. Similarly, the Landfill operator shall be allowed to carry out closure and post-closure activities related to the landfill or the Special Buffer Area provided that such activities are consistent with a County-approved closure plan and with the uses of the land allowed by these Conditions of Approval.</p> <p>The County may require the Landfill operator to maintain the Special Buffer Area, subsequent to dedication, at the operator's expense. Maintenance shall include security, weed control, erosion control and the provision of fire trails.</p>	Completed	<p>The landfill operator submitted a letter to the County Board of Supervisors with an Offer to Dedicate on October 23, 1991. The County Board of Supervisors formally accepted the dedication offer in the form of a Board Order "Acceptance of Development Rights for Special Buffer Area, Keller Canyon Landfill" recorded on November 19, 1996.</p> <p>No waste disposal has occurred in the Special Buffer Area. Limited site development occurred consistent with the Dedication of Development Rights of the Board Order and Report of Disposal Site Information and Final Development and Improvements Plan. This site development has not impaired the Special Buffer Area's capability to accommodate grazing or habitat mitigation. The Dedication of the Special Buffer Area reserves the rights of the landfill owner to carry out mitigation programs required by LUP conditions and/or other permits.</p> <p>Offer letter substantiated by CDD on 10/23/1991. See Community Development Department Memo, V. Conklin to C. Zahn, dated 10/15/1991, and as updated through 10/25/1991.</p>
10.1	<b>Volume Estimation.</b> The Landfill operator shall prepare reports annually estimating the remaining landfill site life (years) and capacity (cubic yards and tons). Reports shall be submitted to the Department of Conservation and Development by March 1st of each year. The Landfill operator shall also submit an initial topographic map prior to receiving wastes.	In Compliance. On-Going	Topographic maps, color aerial photos, and capacity absorption are completed annually. and are available for review by interested agencies during normal business hours. Aerial surveys are required under Condition 17r of the SWFP which is enforced by the LEA. DCD receives landfill capacity and estimated volume of waste in place on an annual basis which is used to satisfy an annual reporting requirement enforced by the State.
10.2	<b>Scales.</b> The Landfill developer shall install certified scale(s) at the landfill to weigh incoming and outgoing trucks. A weigh-ing program, subject to approval by the County Department of Health Services and Director of Weights and Measures, shall be implemented to monitor incoming wastes.	In Compliance. On-Going	Certified scales were installed prior to commencement of landfill operations See County Certificate of Inspection dated 4/23/1992.  The weighing program was approved by the Health Services Department prior to landfill operations (see Memo from C. Nicholson to C. Zahn, CDD dated 3/10/1992).

**EXHIBIT D - Compliance Status Table: Keller Canyon Landfill Land Use Permit 2020-89 Conditions of Approval**

Condition	Condition Description	Compliance Status	Comments
10.3	<p><b>Waste Characterization.</b> The Landfill operator shall participate with transfer station operators serving the landfill in a tracking and reporting program to characterize incoming wastes by generator (customer) name, type, amount, and originating community and perform detailed load inspections on vehicles according to a program specified by the Department of Conservation and Development. Reports shall be submitted to the Department of Conservation and Development on a quarterly basis on or before the landfill reporting deadlines specified in the Disposal Reporting regulations (Title 14).</p>	In Compliance. On-Going	<p>The facility coordinates with transfer station operators on waste characterization as required by the County and the State's Disposal Reporting System regulations. Waste characterization reports are prepared quarterly and submitted to DCD as required under this condition. A new Condition 8.7 has been added which addresses reporting for waste not processed through transfer stations.</p> <p>See letter from KCL dated 4/25/1992 for initial Waste Characterization Program.</p>
11.1	<p><b>Permit Review.</b> The Landfill operator shall submit reports to the Department of Conservation and Development summarizing the compliance status for these Land Use Permit Conditions of Approval annually unless otherwise specified by the Director of Conservation and Development. The Board of Supervisors will hold annual public hearings to review the Conditions of Approval for this Land Use Permit for three years beginning one year after the commencement of operations of the Landfill. The Board may refer proposed changes to the Land Use Permit to the County Planning Commission for processing. Thereafter, the County Planning Commission shall hold public hearings on the Land Use Permit at three-year intervals. As a result of a review and public hearing, the County Planning Commission may recommend to the Board of Supervisors new or modified conditions to improve the public health, safety, and welfare or in response to court decisions or regulatory changes. Nothing in this condition shall preclude the Landfill owner from applying for amendments to the Land Use Permit at any time or preclude the County from addressing emergency situations or new requirements imposed by State or Federal legislation or the courts.</p>	In Process	<p><b>UPDATE: This LUP Compliance Review table contains DCD staff input as well as information provided by the landfill operator to satisfy this annual compliance status report requirement in accordance with the Board of Supervisor's approval of modified conditions of approval on September 22, 2015.</b></p> <p><b>Operator applied for an Amendment to the LUP in 2008 which is in process under County File Number LP08-2026. DCD is currently processing the Subsequent EIR for the proposed LUP Amendment.</b></p>
11.2	<p><b>Local Advisory Committee.</b> The Department of Conservation and Development shall organize, and the Landfill developer shall participate in a local advisory committee, consisting of elected representatives of local residents and neighborhood associations, to comment and advise on the development of the landfill and its operations. The Board of Supervisors may sanction the Local Advisory Committee as an official County committee. The committee shall be established as soon as reasonably possible after the Board of Supervisors' approval of this Land Use Permit, if such approval is forthcoming. Meetings shall be initiated following the approval of a Land Use Permit and shall be held at least quarterly through the first two years of landfill operation. Subsequently, meetings may be held annually, but with the provision for meetings on call by the chair or the written request of 3 or more members unless otherwise specified by the County Board of Supervisors. Contra Costa Environmental Health shall be notified at least 10 days in advance of all meetings. Subjects for consideration at meetings will include, but shall not be limited to safety and emergency procedures, landfill fill-related traffic problems, screening of visual impacts and problems of litter, odor, and noise control. Meeting agenda also may include discussion of reports on the landfill construction, operation and maintenance. The Landfill operator shall provide reasonable access to the landfill arranged through the Conservation and Development Department. A surcharge on the tipping fee may be used to fund the advisory group's operations.</p>	Completed	<p>Currently inactive due to action taken by the County Board of Supervisors on ?. The last meeting took place on February 28, 1995. Landfill personnel periodically conduct site tours of the facility for the local community and make presentations to the Bay Point Municipal Advisory Council upon request.</p>

**EXHIBIT D - Compliance Status Table: Keller Canyon Landfill Land Use Permit 2020-89 Conditions of Approval**

Condition	Condition Description	Compliance Status	Comments
11.3	<p><b>Insurance and/or Bonding.</b> The applicant shall provide the insurance and bonds specified by the units of government having approval authority over the project. The applicant/operator is obligated to comply with additional County specified insurance and bonding requirements pursuant to Article 12 of the First Amended Landfill Franchise Agreement. Subjects may include continuity of landfill operation, non-compliance, emergency measures, construction performance, landscaping and closure.</p>	In Compliance. On-Going	<p><b>UPDATE: The landfill operator provides proof of insurance and bonds annually to the Department of Conservation and Development.</b></p> <p>The filing was substantiated by CDD on 10/25/1991. See Community Development Department Memo, V. Conklin to C. Zahn, dated 10/15/1991, and as updated through 10/25/1991. Insurance requirements are specified in Article 12 of the First Amended Landfill Franchise Agreement approved by the County in 1994. See also Condition 25.10.</p> <p>The only agency that required a bond at project approval was the Regional Water Quality Control Board. A Mitigation Bond of \$500,000 (Bond No. 98370) was filed by KCLC with the Regional Board. Landfill facility Insurances and bonds are updated annually according to inflation rates set by CalRecycle. Bonds are updated for closure, post-closure, and corrective action.</p>
11.4	<p><b>Notification Program.</b> The Landfill operator shall prepare and implement a program to notify potential customers and periodically remind existing customers of the landfill's opening and closing times, and the conditions of its use, including waste reduction and recycling requirements, load covering requirements, site access regulations, truck maintenance to conserve fuel and a detailed list of prohibited hazardous wastes and alternative disposal options. Customers shall also be notified and periodically reminded of waste acceptance eligibility criteria so that refuse loads containing materials on the list approved annually pursuant to Condition 8.5 are not being brought directly to the landfill. The program should be prepared in conjunction with the operator(s) of the transfer station(s) serving the landfill consistent with the Board of Supervisors' policies on direct haul (see Conditions 8.5 through 8.7). It shall be approved by the County Department of Conservation and Development.</p>	Completed. On-Going	<p>Notification requirements of this condition are included in sales, customer service, and special waste service agreements/business contracts with users and potential users of the landfill. Signage of operating hours and conditions, conditions of use, and other requirements are posted at the facility entrance. Additionally, the back of every ticket issued to customers at the gate specifies unacceptable waste, and the actions that can be taken by the landfill operator at its sole discretion in the event a customer attempts to deliver unacceptable waste. The applicable waste reduction and recycling requirements can be found in Conditions 5.5 and 8.6.</p>
11.5	<p><b>Development Coordinator.</b> The Landfill owner shall provide a fund to support a County Landfill Development Coordinator, if the County establishes the position, through the period of construction and landfill operations. The Coordinator shall be a staff member or a consultant. The owner shall make quarterly advance payments.</p> <p>The Landfill developer and operator shall provide such information as the Development Coordinator may require to review plans and installations under the purview of the County, except that any requirements for additional studies shall be subject to the approval of the County's Director of Community Development.</p>	In Compliance. On-Going	<p><b>UPDATE: The landfill operator was not asked to fund a Development Coordinator since the last Permit Review in 2014/15.</b></p>
11.6	<p><b>Compliance and Mitigation Monitoring Program.</b> The Landfill operator shall fund the County Department of Conservation and Development's program for monitoring of compliance with these Conditions of Approval and the Environmental Impact Report's mitigation monitoring program.</p>	In Compliance. On-Going	<p><b>UPDATE: The landfill operator continues to reimburse County DCD staff for costs associated with LUP administration and enforcement.</b></p> <p>Landfill owner provides funds to support County staff of the DCD and CCEH as required by this condition of approval.</p>



**EXHIBIT D - Compliance Status Table: Keller Canyon Landfill Land Use Permit 2020-89 Conditions of Approval**

Condition	Condition Description	Compliance Status	Comments
11.7	<p><b>Pre-Annexation Notification.</b> If the Landfill owner decides to request annexation of the Landfill to a city, the owner shall notify the Board of Supervisors at least 180 days in advance of filing any application for such annexation. The Board may require the Landfill owner to consult with it or County staff to determine how solid waste management programs specified in these Conditions of Approval would be carried out subsequent to annexation. In no case shall the annexation relieve the Landfill operator of the financial responsibilities, including payment to the County of mitigation fees, specified in these Conditions.</p>	Not Yet Required	Landfill owner has not requested annexation of the landfill property to a city.
11.8	<p><b>Fee and Surcharge Identification.</b> The Landfill operator (permittee) shall not identify the costs of public agency (County, etc.) fees, charges, or surcharges on bills and receipts issued to landfill users without first obtaining the specific written approval of the County.</p>	In Compliance. On-Going	This Landfill owner is in compliance with this condition. No costs of public agency (County, etc.) fees are identified on customer invoices.
11.9	<p><b>Interpretation of Conditions.</b> The Community Development Department Director is authorized to interpret these Conditions in the event that any clarification is needed.</p>	Informational	Condition Acknowledged.
11.10	<p><b>Conditions Requiring Franchise.</b> Conditions of Approval 4.2, Operative Date, and 13.4, Franchise Agreement Requirement, require a franchise or agreement to be established by this County. All of the terms of said franchise or agreement shall be subordinate to these Conditions of Approval, and these Conditions of Approval shall control in the case of any conflict unless otherwise provided for pursuant to Condition 2.3. There shall be no need to amend these Conditions of Approval or the franchise in the event of such a conflict.</p>	Completed	Original Franchise Agreement was issued on December 4, 1990. The Franchise Agreement was amended on September 13, 1994 as the First Amended Landfill Franchise Agreement. Amendment No. 1 to the First Amended Franchise Agreement was executed on November 1, 1994. Amendment No. 2 to the First Amended Franchise Agreement was executed on February 27, 1996.
11.11	<p><b>Regulations Enforced by Other Agencies.</b> Several of these Conditions of Approval relate, paraphrase or summarize laws and regulations which are imposed and enforced by other governmental agencies which have jurisdiction over particular aspects of this project. It is this Board's intent in adopting these Conditions of Approval to provide the applicant and the public with an overview of the scope of regulation applicable to this project and to provide this County with the authority to exercise enforcement power if deemed necessary in response to violations of such laws and regulations enforced by other agencies. Unless specifically stated in the Conditions of Approval, however, it is not this Board's intent to establish rules or regulations which are stricter than the laws or regulations which are applied to this project by the other agencies with jurisdiction over aspects of this project. If another agency primarily responsible for some aspect of this project finds that any action or inaction is in compliance with, or violates, any such law or regulation, that finding shall be conclusive. If these Conditions of Approval require some approval by any other agency and that agency declines to approve or disapprove the subject matter, such approval shall be deemed to have been given for purposes of these Conditions of Approval.</p>	Informational	Condition Acknowledged. The Department of Conservation and Development is not aware of any approval Keller has sought which was denied by a regulatory agency.
11.12	<p><b>Required Expenditures.</b> This Board does not intend, by requiring the applicant to fund various measures, to make any decision regarding whether or not, or how, any expenditures incurred may be recovered through the rate structure or otherwise by the applicant. Any such decision by this Board shall be reserved for its consideration in the franchise or agreement. No inference regarding this issue is to be drawn from this Board's use of any particular terminology in these Conditions of Approval.</p>	Informational	Condition Acknowledged.

**EXHIBIT D - Compliance Status Table: Keller Canyon Landfill Land Use Permit 2020-89 Conditions of Approval**

Condition	Condition Description	Compliance Status	Comments
11.13	<p><b>Designation of Authority.</b> In any instance where a Condition of Approval provides that this Board will decide or act upon a certain matter, this Board may delegate the initial decision making or action with respect to that matter to the Director of Conservation and Development or such other designee as this Board determines to be appropriate, provided that there shall be a right of appeal to this Board from any decision to the Director of Conservation and Development or other designee.</p>	Informational	Condition Acknowledged.
12.1	<p><b>Rate Approval.</b>                      a) The Board of Supervisors may at its discretion review and approve all rates charged by the landfill operator at the landfill to the extent allowed by the terms of the applicable Franchise Agreement. The rates established by the Board shall be the maximum rates.                      b) The landfill operator shall at all times maintain on file with the County, a current schedule of Base Rates and Gate Rates charged to each customer as required in Section 6.6 of the Landfill Franchise Agreement.                      c) As provided for in Condition 2.3, where there is an inconsistency between the requirement(s) of this or any other rate setting Condition in Section 12 and the terms of the Landfill Franchise Agreement which granted the operator sole discretion over setting the base gate rate charged to customers, the terms of the Landfill Franchise Agreement shall supersede the applicable language in Condition 12.1(a) and 12.2 - 12.6 until such inconsistency no longer exists pursuant to Condition 2.3(d).</p>	In Compliance. On-Going	Applicable conditions and provisions of rate review and approval are implemented through the Franchise Agreement. See Condition 11.10.
12.2	<p><b>Rate Review.</b> If the Board of Supervisors elects to review and approve rates, it should be done annually in accordance with the rate review procedure established by the County. More frequent review of rates may occur if requested by the landfill operator and if the Board determines that changing circumstances warrant such review. The Board may also review rates more frequently if the Board determines that it is in the public interest to do so pursuant to the terms of the Franchise Agreement for the landfill.</p>	No Longer Applicable	Applicable conditions and provisions of rate review and approval are implemented through the Franchise Agreement. See Condition 11.10.
12.3	<p><b>Form and Content of Rate Review Application.</b> The landfill operator shall submit its rate application in a form and content as specified by the County. The Landfill operator shall provide any relevant rate and cost information requested by the County. Such application may require the landfill operator to submit the application on forms and/or using computer software provided by or specified by the County. The County shall have the right to inspect and audit all records of the landfill operators which support its rate review application.</p>	No Longer Applicable	Applicable conditions and provisions of rate review and approval are implemented through the Franchise Agreement. See Condition 11.10.

**EXHIBIT D - Compliance Status Table: Keller Canyon Landfill Land Use Permit 2020-89 Conditions of Approval**

Condition	Condition Description	Compliance Status	Comments
12.4	<p><b>Rate Application Guidelines.</b> The rate application shall be designed to ensure reconciliation of rates with audited company financial statements; detailed year-to-year cost comparisons; documented guidelines for allowable expense categories, accounting methodologies, allowable management costs and other cost elements; unit usage and unit cost data on major expense items; calculation and reporting of company productivity statistics by cost category; and full documentation of assumptions and source materials. The rate application process shall also provide for comparative rate surveys with other similar operations.</p>	No Longer Applicable	Applicable conditions and provisions of rate review and approval are implemented through the Franchise Agreement. See Condition 11.10.
12.5	<p><b>Financial Statement.</b> The landfill operator shall maintain full and complete accounting records in conformity with generally accepted accounting principals applied on a consistent basis. A financial statement for the proceeding fiscal year, in such form and providing such information as the Board may require, shall be submitted with each rate review application. The financial statement shall be prepared and certified by a Certified Public Accountant currently licensed to practice in the State of California. The County, through a Certified Public Accountant appointed by the County for that purpose, shall at all reasonable times have the right to inspect and audit the records of the landfill operator that supports the financial statements. The County reserves the right to determine which records are relevant.</p>	No Longer Applicable	Applicable conditions and provisions of rate review and approval are implemented through the Franchise Agreement. See Condition 11.10.
12.6	<p><b>Scope of Rates.</b> The Board of Supervisors may require that the landfill operator include in its rates collection for purposes other than disposal including but not limited to, charges for funding of inspections, charges relating to origin of waste such as out-of-county waste, franchise or agreement fees, closure and postclosure maintenance of other landfills, solid waste management programs such as general litter pick-up, abandoned vehicle removal, solid waste planning, and any other conditions of approval.</p>	In Compliance. On-Going	Applicable conditions and provisions of rate review and approval are implemented through the Franchise Agreement. See Condition 11.10.
13.1	<p><b>Franchise Compliance and Agreement.</b> The Landfill operator shall be subject to the terms and conditions of any franchise or agreement established by the Board of Supervisors. A draft franchise or agreement shall be submitted with or before the Final Development and Improvements Plan.</p>	Completed. On-Going	The original Franchise Agreement was issued on December 4, 1990. The Franchise Agreement was amended on September 13, 1994 as the First Amended Landfill Franchise Agreement. Amendment No. 1 to the First Amended Franchise Agreement was executed on November 1, 1994. Amendment No. 2 to the First Amended Franchise Agreement was executed on February 27, 1996.
13.2	<p><b>Assignment.</b> The landfill operator and the landfill owners shall not assign or subcontract the franchise or agreement, any part of the franchise or agreement or any obligation of the franchise or agreement without written prior consent of the Board of Supervisors. Unless otherwise specified in the franchise agreement, the term "assignment" shall include any dissolution, merger, consolidation or reorganization of the landfill's ownership or the sale or other transfer of the controlling percentage of the owner's stock in the landfill or the sale of 51% of the value of the assets of the landfill's owners.</p>	Completed. On-Going	Condition Acknowledged.
13.3	<p><b>Contents.</b> The franchise or agreement may contain such provisions as the Board deems necessary, including but not limited to complete indemnification of the County, liability insurance by type and amount, performance bond by type and amount, rights of the County to acquire ownership of the landfill, funding for mitigation and reimbursement of County costs, funding for closure or post-closure costs, franchise or agreement fee fees) rate review and approval procedure and determination of and consequences of breaches of the franchise.</p>	Completed. On-Going	The original Franchise Agreement was issued on December 4, 1990. The Franchise Agreement was amended on September 13, 1994 as the First Amended Landfill Franchise Agreement. Amendment No. 1 to the First Amended Franchise Agreement was executed on November 1, 1994. Amendment No. 2 to the First Amended Franchise Agreement was executed on February 27, 1996.

**EXHIBIT D - Compliance Status Table: Keller Canyon Landfill Land Use Permit 2020-89 Conditions of Approval**

Condition	Condition Description	Compliance Status	Comments
13.4	<p><b>Requirement.</b> Permittee shall not establish, operate or carry on the business of a solid waste facility pursuant to this permit unless and until it has been first granted a franchise (or entered an agreement with the Board of Supervisors).</p>	Completed. On-Going	The original Franchise Agreement was issued on December 4, 1990. The Franchise Agreement was amended on September 13, 1994 as the First Amended Landfill Franchise Agreement. Amendment No. 1 to the First Amended Franchise Agreement was executed on November 1, 1994. Amendment No. 2 to the First Amended Franchise Agreement was executed on February 27, 1996.
13.5	<p><b>County Discretion.</b> Notwithstanding any other provision of this Permit, Permittee acknowledges that the County's discretion to grant or deny one or more said exclusive, non-exclusive or otherwise franchises or similar agreements is not limited or abridged in any manner by this Permit; and that this Permit does not require the approval of any such franchise or agreement. County reserves the right as part of the negotiation and entry of any such franchise or agreement to enter a public-private partnership with the Permittee for the project and/or to pursue the rights of the County to acquire ownership of the Landfill.</p>	Completed. On-Going	Condition Acknowledged.
14.1	<p><b>Initial Development and Improvements Plan.</b> The Initial Development and Improvements Plan approved by this Land Use Permit, and modified by these Conditions of Approval, shall consist of the following schematic plans included in the applicant's January 31, 1989 entitlement application, the Keller Canyon Landfill Comprehensive Project Description (February 1989) and addendum (December 1989), and the 3-volume Site Characterization Report (September 1989).</p> <ul style="list-style-type: none"> <li>a) Grading/Excavation Plans with fill limits for each phase.</li> <li>b) Layout for Groundwater Collection System.</li> <li>c) Liner System Cross-section and Installation Sequence.</li> <li>d) Leachate Collection System Layout Plan.</li> <li>e) Gas Collection Layout Plans for each phase.</li> <li>f) Surface Water Drainage Plan.</li> <li>g) Facilities Site Plan for Operations and Maintenance.</li> <li>h) Leachate, Landfill, Gas and Water Storage Facility.</li> <li>i) Landfill Access Road Plans Profiles, Typical Section.</li> <li>j) Bailey Road Plan and Typical Section.</li> <li>k) Landscape Facilities Site Plan for Operations and Maintenance.</li> <li>l) Landscape Plan for Leachate, Landfill Gas and Water Storage Facilities.</li> <li>m) Landscape Plan.</li> </ul>	Completed	All plan elements outlined in this condition of approval for the Initial Development and Improvements Plan were submitted and subsequently completed in final form in the Final Development and Improvements Plan (FDIP).

**EXHIBIT D - Compliance Status Table: Keller Canyon Landfill Land Use Permit 2020-89 Conditions of Approval**

Condition	Condition Description	Compliance Status	Comments
14.2	<p><b>Regulatory Agency Approvals.</b> Subsequent to the approval of this Land Use Permit, the Landfill Developer shall obtain approvals from the regulatory agencies having jurisdiction over the project, and obtain their detailed requirements for building, serving, and operating the Landfill. The approvals shall include, but are not limited to:</p> <p>a) Waste Discharge Requirements from the Regional Water Quality Control Board.                      b) Authority to Construct (and Authority to Operate Requirements) from the Bay Area Air Quality Management District.                      c) Wetland Modification Permit from the Army Corps of Engineers.                      d) Streambed Alteration Agreement from the State Department of Fish and Wildlife.</p> <p>The Landfill developer shall notify the Department of Conservation and Development if proposed or adopted permit conditions or requirements of other regulatory agencies do not appear to be consistent with this Land Use Permit or the Landfill's Environmental Impact Report. The Landfill operator shall submit to the County copies of all new and modified permits or entitlements at the time each is issued or approved by the applicable regulatory agency.</p>	Completed. Updated As Needed	<p><b>UPDATE: Permits updated are shown below in bold font.</b>                      The permits and approvals involved compliance with prevailing State and federal regulations and design standards for a Class II sanitary landfill and represent implementation of many mitigation measures specified in the 1990 Final EIR. All other project approvals were obtained and updated as follows:                      * <b>Solid Waste Facility Permit (SWFP) #07-AA-0032</b>, issued April 29, 1992 by Contra Costa Environmental Health, with concurrence from the former California Integrated Waste Management Board, now the California Department of Resources Recycling and Recovery (CalRecycle). <b>Last reviewed and modified in 2014. Next permit review in 2019.</b>                      * Waste Discharge Requirements (WDRs) Orders No. 91-052, 97-060, 98-081, 00-091, 01-240, R2-2003-0063, R2-2004-0080, issued 3/20/91 by the California Regional Water Quality Control Board, San Francisco Bay Region (RWQCB). Last amended 2004;                      * <b>Title V Permit Major Facility Review</b> Plant No. A4618 <b>last issued March 17, 2016</b> by the Bay Area Air Quality Management District (BAAQMD);* Authority to Construct/Permit to Operate Plant No. 4618 reviewed annually by the BAAQMD;                      * National Pollution Discharge Elimination System Permit #2-07S006887 issued September 17,1992 by the U.S. Environmental Protection Agency;                      * Nation-Wide Permit No. 26t, Section 404 of the Clean Water Act, issued June 14, 1991 by the U.S. Army Corps of Engineers;                      * Conditional Certification under the Clean Water Act, Section 401, issued October 3, 1991 by the California Regional Water Quality Control Board, San Francisco Bay Region;* Streambed Alteration Agreement No. 1461-90 by the California Department of Fish and Game was signed by the Warden on 8/4/1991 and executed by the Operator on October 18, 1991. Lawlor Creek (No. 1461-90); Sedimentation basin, drainages, culverts (No. 1462-90); and wetlands construction (No. 1463-90).                      * Industrial Waste Discharge Permit #292150-S last issued 2008 by the Delta-Diablo Sanitation District;                      * Cancellation of the Land Conservation Act (Williamson Act) Contract #6-71 on July 14, 1990 and amended on October 15, 1991 by Contra Costa County.                      * Report of Disposal Site Information (RDSI), 1992, pursuant to SWFP 07-AA-0032, as amended.</p> <p>See Community Development Department Memo, V. Conklin to C. Zahn, dated 10/15/1991, and as updated through 10/25/1991.</p>
14.3	<p><b>Improvements Requirements.</b> Subsequent to the approval of this Land Use Permit, the Landfill developer shall obtain approvals from the agencies, utilities, and parties having jurisdiction or control over the on-site and off-site improvements required by this Land Use Permit or by agencies having regulatory jurisdiction over the project. The Landfill developer shall notify the Conservation and Development Department if proposed or adopted Conditions or requirements do not appear to be consistent with this Land Use Permit or the Landfill's Environmental Impact Report.</p>	Completed. Updated As Needed	<p>All approvals were obtained from jurisdictional agencies as described above in Condition 14.2.</p> <p>The Department of Conservation and Development has not received any notice from the Landfill operator stating that the land use conditions appear to be inconsistent with the LUP or Environmental Impact Report.</p>

**EXHIBIT D - Compliance Status Table: Keller Canyon Landfill Land Use Permit 2020-89 Conditions of Approval**

Condition	Condition Description	Compliance Status	Comments
15.1	<p><b>Final Development and Improvements Plan.</b> Subsequent to the approval of the Land Use Permit but prior to the commencement of any construction, the Landfill developer shall submit a Development and Improvements Plan to the Conservation and Development Department and obtain the approval of the Director of Community Development. The Development and Improvements Plan shall be consistent with the project approved by the Land Use Permit, but prepared to a level of detail appropriate for the review of the engineering and construction of the project's on-site and off-site improvements. It shall be internally consistent with the project's Environmental Impact Report findings, these Conditions of Approval, regulatory agencies and others having discretionary approvals over the project, and the Solid Waste Facilities Permit issued by Contra Costa Environmental Health. The Conservation and Development Department will coordinate the review of the plan by Contra Costa Environmental Health, the Public Works Department, and other appropriate units of government. The Landfill developer shall comply with all provisions of the final Developments and Improvements Plan.</p> <p>The Development and Improvements Plan shall include:</p> <p>a) Site Development Plan, as described in the following sections.                      b) A Surface Water Management and Sediment Control Plan, (Section 18).                      c) An Agricultural and Habitat Enhancement Plan, (Section 23).                      d) A Waste Reduction and Resource Recovery Program, (Section 31).                      e) A Landscape (screening) Plan, (Section 22).                      f) A Landfill Gas Management/Air Quality Monitoring/Odor Control Plan, Section 20).                      g) A Leachate Management Plan, (Section 17).                      h) A Site Services and Utilities Plan (Section 30).                      i) A Traffic/Circulation Plan, (Section 29).</p>	Completed. Updated As Needed	<p><b>UPDATE: As needed, there may be updates to various FDIP Sections, such as Sections 6.3 - 6.5 which relate to the requirements in Conditions 31.4 - 31.6.</b></p> <p>A copy of the FDIP is kept at the KCL and County DCD offices and is available for review during normal business hours. Some of the documents listed below have been updated by other permits in effect at KCL. The FDIP was formally submitted on July 23, 1991 to CDD. The FDIP served as the primary basis for facility review. CDD coordinated reviews of the FDIP with other County department. The landfill operator updated elements of the FDIP as directed by CDD.</p> <ul style="list-style-type: none"> <li>* Landfill (Site) Development Plan included in FDIP, Section 3</li> <li>* Surface Water Management and Sediment Control Plan included in FDIP, Section 4</li> <li>* Agricultural and Habitat Enhancement Plan included in FDIP, Section 5</li> <li>* Waste Reduction and Resource Recovery Plan included in FDIP, Section 6</li> <li>* Landscape (Screening) Plan included in FDIP, Section 7</li> <li>* Landfill Gas Management/Air Quality Monitoring/Odor Control Plan included in FDIP, Section 8</li> <li>* Leachate Management Plan included in FDIP, Section 9</li> <li>* Site Services and Utilities Plan included in FDIP, Section 10</li> <li>* Traffic and Circulation Plan included in FDIP, Section 11</li> </ul>
15.2	<p>In approving the Development and Improvements Plan, the Conservation and Development Department Director may allow the Landfill developer to phase construction of landfill modules and other features, except where timing is specified in these conditions. The submittal of the Development and Improvements Plan components may reflect this phasing.</p>	In Compliance. On-Going	<p>DCD authorized initial phased construction of landfill facilities and modules in 1991. See Memo from C. Zahn to the Board of Supervisors dated 10/25/1991.</p>
16.1	<p><b>Landfill Slopes Objective.</b> Landfill slopes shall be engineered to provide static and dynamic (seismic) stability under design criteria for Class II Landfills.</p>	Objective	<p>This is solely an Objective. See Conditions 16.2 - 16.12.</p> <p>All engineering design related to landfill slopes meet design criteria for Class II landfills and are approved by the RWQCB. The facility is in compliance with measures incorporated into the WDRs (RWQCB Order 01-040) [(e.g. Specification B.8, (Maintenance of Disposal Area slopes), B.14 (Reports prepared by registered engineers and geologists).</p> <p>Letter of authorization from the RWQCB was substantiated by CDD on 10/23/1991.</p>

**EXHIBIT D - Compliance Status Table: Keller Canyon Landfill Land Use Permit 2020-89 Conditions of Approval**

Condition	Condition Description	Compliance Status	Comments
16.2	<p><b>Seismic Design.</b> The Landfill, its drainage features and operating components (lifts, berms, liners, sediment pond, leachate and gas collection systems and major stockpiles) shall be designed to withstand earthquakes as specified in applicable regulations. The Landfill developer shall utilize a MCE (design earthquake) specified by the San Francisco Regional Water Quality Control Board. The Landfill developer shall provide substantiation in the Final Development and Improvements Plan that the Landfill design will withstand the MCE.</p>	In Compliance. On-Going	<p>The facility is in compliance with seismic design criteria and other measures incorporated into the WDRs (RWQCB Order 01-040) [(e.g. Specification B.5 (engineered structures to withstand maximum credible earthquake (MCE), Provision C.5 (submit proposal for slope and seismic analysis) and (slope and seismic analysis for new construction). WDRs are monitored by the RWQCB.</p> <p>See Community Development Department Memo, V. Conklin to C. Zahn, dated 10/15/1991, and as updated through 10/25/1991.</p>
16.3	<p><b>Landslide Study.</b> The Landfill developer shall employ a licensed geo-technical consultant to conduct a supplementary study of landslides and slope stability in areas of the site affected by Landfill and improvements grading. The study shall be performed by a licensed geotechnical professional. The study shall be subject to the approval of the County and the San Francisco Regional Water Quality Control Board. The Landfill developer shall incorporate the results of the study into the site grading program and the designs of overlying structures, which shall be included in the Development and Improvements Plan.</p>	Completed. On-Going	<p>The original preliminary Landslide Study is included in the FDIP, Appendix G. The facility is in compliance with the WDRs Section 19 and Title 27 requirements, including Section 21750(f)(5)(A) requiring the discharger to provide slope stability analyses prior to construction, ensuring the integrity of the waste management unit under both static and dynamic conditions throughout the unit's life.</p> <p>A certified study by a licensed geotechnical professional was substantiated by DCD on 10/25/1991. See Memo, V. Conklin to C. Zahn, dated 10/15/1991, and as updated through 10/25/1991.</p>
16.4	<p><b>Geotechnical Inspector.</b> The Landfill operator shall fund the costs of an independent geotechnical consultant, who shall be selected by and be responsible to the County. The Inspector shall inspect the installation and condition of liners, leachate control facilities and other installations, identified by the County, as they are installed and periodically thereafter as directed by the County. This provision shall remain in force over the life of the landfill.</p>	In Compliance. On-Going	<p>Design reports for all phases of site development are submitted to the County for review and approval. The operator was asked to provide funding for the County to contract with a geotechnical consulting firm to assist with the review of design reports for at least the first five years of phased landfill construction. Professional geotechnical consultants are involved in all phases of site development as required by WDRs Specification B.14 (Reports prepared by registered engineers and geologists). Liner installation is routinely inspected during construction of each new landfill disposal phase in accordance with requirements of this LUP and the WDRs monitored and enforced by the RWQCB. The County may elect to retain geotechnical expertise in the future at the operator's expense pursuant to this Condition.</p>
16.5	<p><b>Landfill Design Stability.</b> The Landfill developer shall provide a static and dynamic stability analysis of the final engineering design of the Landfill and its appurtenant improvements. The stability analysis method and the resulting analysis shall be approved by the County Conservation and Development Department and the San Francisco Regional Water Quality Control Board and included in the Final Development and Improvements Plan.</p>	Completed. On-Going	<p>An early study of landfill design stability is included in FDIP, Section 3.3. In 2002, analyses were performed to evaluate the static and seismic stability of the proposed base grades, the final fill grades and the proposed cover system under five cases involving different locations proximate to landslides, and under different final fill grades and cover parameters. The presentation and discussion of these analyses is organized in an internal report by GeoSyntec, 2002.</p> <p>All KCL design documents must comply with the WDRs Section 19. Title 27 Requirements, which requires that any future developments must comply with Section 21750(f)(5)(A), requiring the discharger to provide slope stability analyses, ensuring the integrity of the waste management unit under both static and dynamic conditions throughout the unit's life.</p> <p>See Community Development Department Memo, V. Conklin to C. Zahn, dated 10/15/1991, and as updated through 10/25/1991.</p>

**EXHIBIT D - Compliance Status Table: Keller Canyon Landfill Land Use Permit 2020-89 Conditions of Approval**

Condition	Condition Description	Compliance Status	Comments
16.6	<p><b>Slope Monitoring.</b> The Landfill operator shall install and maintain slope monitoring stakes on landslides and sensitive slopes which could affect an operating Landfill. The monitoring program shall be approved by the County Department of Conservation and Development.</p>	Completed. On-Going	<p>Included in the original Landslide Study in the FDIP, Appendix G. Slope monitoring is conducted consistently to identify potential problems.</p> <p>The facility is in compliance with measures incorporated into the WDRs (RWQCB Order 01-040) [(e.g. Specification B.8, (Maintenance of Disposal Area slopes), B.14 (Reports prepared by registered engineers and geologists), Provision C.5</p> <p>See Community Development Department Memo, V. Conklin to C. Zahn, dated 10/15/1991, and as updated through 10/25/1991.</p>
16.7	<p><b>Settlement Program.</b> The Landfill developer shall implement a program to prevent fill settlement and an inspection program to detect and correct settlement problems. The developer shall compact the refuse and cover materials to maximum strength and design and maintain the necessary slope gradient to ensure proper surface water drainage. A network of settlement platforms shall be installed to monitor fill settlement at critical points. The station specifications and locations shall be included in the Improvements and Development Plan. The Settlement program shall be subject to the approval of the County Conservation and Development Department and the San Francisco Regional Water Quality Control Board.</p>	Completed. On-Going	<p>Included in FDIP, Section 3.4. Landfill settlement is also addressed in the Draft JTD. Compaction of waste and cover is performed in compliance with State requirements and Condition 17k(c) of the SWFP.</p> <p>The facility is in compliance with seismic design criteria and other measures incorporated into the WDRs (RWQCB Order 01-040) [(e.g. Specification B.5 (engineered structures to withstand maximum credible earthquake (MCE), Provision C.5 (submit proposal for slope and seismic analysis) and (slope and seismic analysis for new construction). WDRs are monitored by the RWQCB.</p> <p>See Community Development Department Memo, V. Conklin to C. Zahn, dated 10/15/1991, and as updated through 10/25/1991.</p>
16.8	<p><b>Emergency Landslide and Earthquake Program.</b> The Landfill operator shall prepare and implement an emergency program for inspecting the Landfill facility, dealing with failures and providing for uninterrupted refuse handling for implementation following a landslide and/or earthquake. The program shall be subject to the approval of the County Department of Conservation and Development, Contra Costa Environmental Health and the Regional Water Quality Control Board.</p>	Completed. On-Going	<p>A Post-Earthquake Program is included in the 1992 RDSI, and FDIP, Section 3.5, and was submitted to the RWQCB in compliance with Provision C.3 of the WDRs in Order No. 91-052.</p> <p>See Community Development Department Memo, V. Conklin to C. Zahn, dated 10/15/1991, and as updated through 10/25/1991.</p>
16.9	<p><b>Settlement Pond Embankment Design.</b> The Landfill developer shall design the settlement pond to control foundation seepage through the means of a filter or other materials.</p>	Completed	<p>Settlement pond embankment was designed per requirements of the WDRs and approved by the RWQCB. Also see Community Development Department Letter from H. Bragdon to the Board of Supervisors dated 12/13/1991; and Building Inspection memo from S. Thung to C. Zahn dated 1/21/1992. The facility is in compliance with measures incorporated into the WDRs (RWQCB Order 01-040) [e.g. Prohibition A.5 (Detailed construction plans of containment structures), C.18 (Notification of containment facility failure). WDRs are monitored by the RWQCB.</p>



**EXHIBIT D - Compliance Status Table: Keller Canyon Landfill Land Use Permit 2020-89 Conditions of Approval**

Condition	Condition Description	Compliance Status	Comments
16.10	<p><b>Settlement Pond(s) Monitoring Program.</b> The Landfill operator shall prepare and implement a failure prevention and warning system, including daily monitoring and visual inspection, for the sedimentation ponds. The program shall be approved by the County Conservation and Development Department and shall be included in the Development and Improvements Plan.</p>	In Compliance. On-Going	<p>Included in FDIP, Section 3.5. Sedimentation ponds and stormwater discharge points are inspected at a minimum on a weekly basis. Daily inspections have proved unnecessary due to the static nature of the facilities particularly during the non-rainy season.</p> <p>The facility is in compliance with measures incorporated into the WDRs (RWQCB Order 01-040) [e.g. Prohibition A.5 (Detailed construction plans of containment structures), C.18 (Notification of containment facility failure). WDRs are monitored by the RWQCB.</p>
16.11	<p><b>Stockpile Stability.</b> Commencing with the onset of stockpiling, the Landfill operator shall continually analyze daily cover material stockpiles for stability to determine allowable heights and/or slopes. The results shall be available to the County Conservation and Development Department and Contra Costa Environmental Health on demand.</p>	In Compliance. On-Going	<p>Stockpiled cover materials are analyzed daily for stability as standard operating procedure and Condition 17k(a) of the SWFP. Results of stockpile stability analyses are available to the Department of Conservation and Development and the LEA upon request.</p>
16.12	<p><b>Unstable Areas.</b> Areas with landslide potential to affect land-fill operations shall be stabilized through excavation or other methods such as compacting or the construction of retaining walls. Grading operations shall be performed in a manner which shall not destabilize slopes.</p>	In Compliance. On-Going	<p>Potential landslide areas have been identified. Stabilization methods are to be determined in the field. Significant landslide events occurred at the landfill site in 1996 and 1998. All corrective actions were reviewed and approved by the RWQCB and are the subject of RWQCB Order 01-040 Title 27 Requirements Items 16, 17, and 18.</p> <p>Measures are incorporated into the facility's WDRs (RWQCB Order 01-040) [(e.g. Specification B.8, (Maintenance of Disposal Area slopes), B.14 (Reports prepared by registered engineers and geologists), Provision C.5</p>
17.1	<p><b>Groundwater Protection Objective.</b> The Landfill shall not impair the beneficial uses of groundwater on the Landfill site or in its vicinity. The design and monitoring of the Landfill shall be based upon the assumption of the existence of high permeability interconnecting cracks and fissures in the underlying strata allowing the potential of groundwater transmission.</p>	Objective	<p>This is solely an Objective. See Conditions 17.2 - 17.6.</p> <p>Implementation of Section 17, Groundwater Protection conditions related to landfill site design and monitoring has maintained beneficial uses of groundwater at the landfill site and surrounding vicinity.</p>
17.2	<p><b>Landfill Liner.</b> The Landfill developer shall install a engineered liner system, including a clay liner and a high-density polyethylene liner, which meets State Class II Landfill standards. The liner shall be approved by the San Francisco Bay Regional Water Quality Control Board and its specifications and design shall be included in the Development and Improvements Plan. The liner shall be designed to withstand the Maximum Credible Earthquake as specified by the Regional Water quality Control Board. See Section 16.</p>	In Compliance. On-Going	<p><b>UPDATE: Landfill liner design is detailed in reports submitted for each phase of the phased development which are then subject to review and approval by the RWQCB and DCD.</b></p> <p>The KCL base liner system is designed in accordance with 27 CCR, Section 20330 and WDR 01-040 Specification B.13 requirements for a Class II liner. The base liner components generally consist of (from bottom to top): Prepared subgrade; A 12-inch underdrain granular layer; A non-woven geotextile filter; A 24-inch thick low-permeability soil layer (maximum permeability of 1 x 10<sup>-7</sup> cm/sec); A 80-mil high density polyethylene (HDPE) liner (double textured); A non-woven geotextile cushion layer; A 12-inch dendritic LCRS gravel layer; A non-woven geotextile filter; and A 12-inch thick operations (protective cover soil) layer.</p>

**EXHIBIT D - Compliance Status Table: Keller Canyon Landfill Land Use Permit 2020-89 Conditions of Approval**

Condition	Condition Description	Compliance Status	Comments
17.3	<p><b>Leachate Collection System.</b> The Landfill developer shall install a leachate collection system which shall meet State Class II standards. The leachate collection system shall be approved by the San Francisco Bay Regional Water Quality Control Board, and its specifications and design shall be included in the Development and Improvements Plan. Leachate shall be contained by a double liner system consisting of a two-foot thick layer of clay overlain by a synthetic membrane liner. Enclosed storage tank design for leachate treatment shall meet hazardous waste storage requirements, which includes a double liner system with perimeter berms. An emergency connector shall be installed between the pre- and post-treatment tanks in the event of an overflow situation. A tanker truck shall be readily available for emergency purposes. Measures shall be taken to limit leachate formation, such as prompt covering of waste and provision of surface water drainage away from landfill areas.</p>	In Compliance. On-Going	<p>The facility is in compliance with measures incorporated into the WDRs (RWQCB Order 01-040) [e.g. Prohibition A.9 (leachate discharges), Specification B.4 (LCRS design), B.17 (Leachate sump seismic design), Provisions C.1 (Compliance with Specifications and Provisions of Order), C.3 Groundwater monitoring. WDRs are monitored and enforced by the RWQCB.</p> <p>The Leachate Collection and Removal System (LCRS) was designed, constructed, and is operated in accordance with RWQCB requirements. The leachate collection system was designed to handle twice the maximum daily leachate generation rate from the facility. Leachate collected in the LCRS flows through the drainage layer to pipes and subsequently into two 66,000 gallon leachate storage tanks located adjacent to the landfill gas flare station. The storage tanks are located inside a reinforced concrete secondary containment area set below surrounding grades. The leachate is disposed by re-injection into the waste mass in accordance with RWQCB requirements. The level of leachate in the two tanks are observed and recorded daily. During dry months (April to October), leachate is withdrawn when the tank liquid level is observed at approximately 4-feet or 16,500-gallons. Due to the potential increase in the volume of leachate from winter rains, the tank levels are kept as low as feasible in the wet months.</p> <p>See WDRs Specifications 4,9,13, 17, and 18; and Provision 4. See Community Development Department letter from C. Zahn to B. Olney (KCLC) dated 3/12/1992, which authorized installation of leachate tanks.</p>
17.4	<p><b>Surface Drainage System.</b> Water collected in the underdrain system beneath the landfill shall be monitored on a regular basis specified by the San Francisco Regional Water Quality Control Board. If contaminated, this water shall be treated as leachate. See Section 18.2.</p>	In Compliance. On-Going	<p><b>UPDATE: The most recent 2016 First Semi-Annual Report and 2015 Annual Water Quality Monitoring Report prepared by the Landfill operator provides results of underdrain monitoring. KCLC continues to perform monthly sampling of the underdrain.</b></p> <p>The surface drainage system is monitored in accordance with RWQCB WDR detection monitoring requirements (Monitoring Programs 36. Surface Water) and the facility Self-Monitoring Program Parts A and B. Annual monitoring reports are filed with the RWQCB and are available for review at the landfill office during normal business hours. The facility is in compliance with measures incorporated into the WDRs (RWQCB Order 01-040) [e.g. Specification B.3 (Surface Drainage)].</p>
17.5	<p><b>Groundwater Monitoring.</b> The Landfill developer shall install a groundwater monitoring system and implement a monitoring program, as required by the San Francisco Bay Regional Water Quality Control Board. The monitoring stations' specifications, locations, and their frequency of monitoring shall be included in the Development and Improvements Plan. The proposed monitoring program shall be subject to review by Contra Costa Environmental Health and the County Conservation and Development Department.</p>	In Compliance. On-Going	<p><b>UPDATE: Groundwater monitoring results for 2015 and 2016 are summarized in the report "First 2016 Semi-Annual Report and 2015 Annual Water Quality Monitoring Report, dated April 30, 2016." Reports are now filed on-line with the California Regional Water Quality Board, San Francisco Bay Region.</b></p> <p>The original groundwater monitoring program is included in FDIP, Section 9.3, and Appendix A. All monitoring of groundwater is performed in accordance with the RWQCB WDR requirements under Monitoring Programs 34. Groundwater and 35. Leachate. The facility is in compliance with measures for groundwater monitoring into the WDRs (RWQCB Order 01-040). Also see Section C, Provisions, and California Environmental Quality Act section of Order, Items 38 through 40).</p> <p>The existing groundwater monitoring network at the KCL has been designed to provide early detection of a release from wastes to groundwater. The monitoring systems currently installed was designed and certified by a registered (geologist or civil) engineer. The boring logs were prepared under the direction of a registered geologist or civil engineer and submitted to the RWQCB.</p>

**EXHIBIT D - Compliance Status Table: Keller Canyon Landfill Land Use Permit 2020-89 Conditions of Approval**

Condition	Condition Description	Compliance Status	Comments
17.6	<p><b>Downstream Well Monitoring.</b> The groundwater monitoring program shall include selected wells down gradient from the site. The wells shall be subject to approval by the San Francisco Regional Water Quality Control Board. The Landfill operator shall sample and analyze water from these wells as required by the Regional Water Quality Control Board. The location of these wells shall be identified on the Development and Improvements Plan.</p>	In Compliance. On-Going	<p><b>UPDATE: Downstream well monitoring results for 2015 and 2016 are summarized in the report "First 2016 Semi-Annual Report and 2015 Annual Water Quality Monitoring Report, dated April 30, 2016." Reports are now filed on-line with the California Regional Water Quality Board, San Francisco Bay Region.</b></p> <p>A downstream well monitoring program is included in the FDIP, Section 9.4, and Appendix A. Also see WDRs Self-Monitoring Program. The locations and design of wells were approved by CCEH and the RWQCB. All monitoring of groundwater is performed in accordance with the RWQCB requirements and the WDRs.</p> <p>Facility is in compliance with measures for groundwater monitoring incorporated into the WDRs (RWQCB Order 01-040). See Section C, Provisions. Also see Condition 17.5 above.</p>
17.7	<p><b>Baseline Water Characterization.</b> The Landfill developer shall conduct a groundwater characterization study for at least a one-year period following the approval of the Land Use Permit. The procedures for the study shall be specified by the San Francisco Bay Water Quality Control Board and Contra Costa Environmental Health.</p>	Completed	<p>Included in FDIP, Section 9.3, and FDIP Appendix A Waste Discharge Requirements and 401 Certification, Baseline characterization was performed in accordance with the WDRs Self-Monitoring Program Section 4C. Groundwater Characterization studies performed were reviewed and approved by the RWQCB. There is no record of a CCEH approval of a baseline characterization report; however, CCEH has deferred to the RWQCB approval on other similar conditions.</p>
17.8	<p><b>Liquid Waste Disposal.</b> The Landfill operator shall comply with the requirements of the Regional Water Quality Control Board for disposal of de-watered sewage and other utilities' sludges in the Landfill to prevent excess liquid concentrations. The Landfill operator shall not accept other liquid wastes.</p>	In Compliance. On-Going	<p>The landfill facility is in compliance with RWQCB and SWFP requirements for handling and disposal of sludge material. The discharge of liquid or semi-solid waste to the landfill (i.e. waste containing less than 50% solids by weight), other than dewatered sewage or water treatment sludge as described in Section 20220(c) of Title 27, is prohibited.</p>
17.9	<p><b>Drainage Grading.</b> The Landfill developer shall grade completed fill areas to convey surface run-off to ditches at the fill perimeter to limit infiltration into the Landfill. The grading specifications shall be included in the Development and Improvements Plan.</p>	In Compliance. On-Going	<p>All grading and fill operations are consistent with plans and specifications included in FDIP, Section 9.5. Facility is in compliance with measures incorporated into the WDRs (RWQCB Order 01-040) [e.g. Specification B.3 (Surface Drainage)].</p>
17.10	<p><b>Leachate Management.</b> The Landfill operator may reapply leachate removed from the leachate collection sumps to the Landfill for absorption by solid waste, or arrange for its transportation (pretreated if necessary) to an appropriate treatment and disposal facility. If leachate is returned to the fill area, it shall be injected under the Landfill's cover rather than applied over its surface. The return of leachate to the Landfill shall be subject to the solids-to-liquids ratio restrictions defined by the San Francisco Bay Regional Water Quality Control Board and Contra Costa Environmental Health. If leachate is transported to an off-site disposal/treatment facility, it shall be pretreated on-site to meet all requirements of such facility before transport. If leachate build up becomes a problem, Contra Costa Environmental Health may require additional remedial measures, such as the placement of more soil cover, or the installment of a low-permeability earthen or synthetic cover. The Leachate Management Program shall be included as part of the Site Design Plan.</p>	In Compliance. On-Going	<p><b>UPDATE: Leachate monitoring results for 2015 and 2016 are summarized in the report "First 2016 Semi-Annual Report and 2015 Annual Water Quality Monitoring Report, dated April 30, 2016." Reports are now filed on-line with the California Regional Water Quality Board, San Francisco Bay Region.</b></p> <p>The Leachate Management Plan is included in the FDIP, Sections 9.1 through 9.8. A Leachate Collection Tank Log records daily measured levels, gallons in tanks 1 and 2, truck loads and gallons out. Leachate is sampled and analyzed quarterly. Leachate is disposed by re-injection into the waste mass in accordance with RWQCB requirements. The level of leachate in two leachate storage tanks are observed and recorded daily. During dry months (April to October), leachate is withdrawn when the tank liquid level is observed at approximately 4-feet or 16,500-gallons. Due to the potential increase in the volume of leachate from winter rains, the tank levels are kept as low as feasible in the wet months.</p> <p>The facility is in compliance with measures incorporated into the WDRs (RWQCB Order 01-040) [e.g. Prohibition A.9 (leachate discharges), Specification B.4 (LCRS design), B.17 (Leachate sump seismic design), Provisions C.1 (Compliance with Specifications and Provisions of Order), C.3 Groundwater monitoring. WDRs are monitored and enforced by the RWQCB.</p>

**EXHIBIT D - Compliance Status Table: Keller Canyon Landfill Land Use Permit 2020-89 Conditions of Approval**

Condition	Condition Description	Compliance Status	Comments
17.11	<b>Water Balance Calculations.</b> The Landfill operator shall provide water balance calculations, when requested by the Regional Water Quality Control Board or other applicable regulatory agency, to evaluate intermediate stages of Landfill operation to ensure the maintenance of a proper solids-to-liquid ratio.	Not Yet Required	Water balance data will be provided upon request by DCD and/or CCEH. The landfill operator has confirmed that the facility has not yet reached the intermediate stages.
17.12	<b>Leachate Holding Tanks.</b> Holding tanks for leachate shall be tested to ensure chemical compatibility to prevent chemical degradation of said tanks. The Landfill developer shall submit test results to the Regional Water Quality Control Board and Contra Costa Environmental Health, prior to the submission of the Development and Improvements Plan.	In Compliance. On-Going	The initial tests were completed July 22, 1991. The original design and manufacture of leachate holding tanks were in accordance with RWQCB requirements.  See Health Services Department memo from M. Schott to C. Zahn (CDD) dated 10/13/1991. Schott stated approval recommended from RWQCB and that HSD had no further action and deferred to the RWQCB approval.
17.13	<b>On-Site Water Supply Wells.</b> The Landfill developer shall construct the proposed on-site water supply wells after a hydro-geologic investigation has determined flow direction and relationship between water bearing strata if any. Water supply wells shall utilize separate water bearing strata, and shall be sealed to prevent communication between shallow and deep ground water. The locations and characteristics of water supply wells shall be described in the Development and Improvements Plan, and shall be subject to Contra Costa Environmental Health and San Francisco Regional Water Quality Control Board approval. Pump tests shall be provided for on-site wells located within 500 feet of any domestic well to evaluate interference between wells.	Completed. On-Going	An on-site water supply well was constructed in accordance with County CCEH and RWQCB requirements. Well design plan is included in FDIP, Section 10.2. Water for operations at the KCL is supplied by a well approximately 1,000 feet north of the maintenance shop and water storage tank. The well meets the pumping capacity requirements of this condition. Permits to construct the wells were issued by HSD on December 12, 1992 and April 15, 1993.
17.14	<b>Off-Site Water Well Contamination.</b> If the water quality of nearby domestic water supplies is impaired by Landfill leachate, the Landfill operator shall take immediate remedial action that is acceptable to Contra Costa Environmental Health and the San Francisco Regional Water Quality Control Board. The source of contamination shall be identified and immediately repaired. Remedial measures shall include but are not limited to extraction wells and slurry walls. The Landfill operator may be required to replace the impaired water supply.	Not Yet Required	Condition Acknowledged. The locations of groundwater wells within a mile of the existing KCL have been mapped and available information for the wells has been collected. Nearby domestic water supplies have not been impaired by landfill leachate. No remedial action has been required of the Landfill owner/operator.
17.15	<b>Liner Installation Inspection.</b> See Condition 16.4.	Cross-Reference	This condition solely cross-references another LUP condition. See Condition 16.4.
17.16	<b>Secondary Containment.</b> The Landfill developer shall construct a secondary containment system capable of containing 1.5 times the volume of each leachate-holding tank.	Completed	The storage tanks are located inside a reinforced concrete secondary containment area set below surrounding grades. The containment area meets the requirements of this condition. See Community Development Department letter from C. Zahn to B. Olney (KCLC) dated 12/13/1992, which authorized construction of the leachate storage tank foundations for both leachate tanks have a capacity of 64,000 gallons each, and a concrete secondary containment with a capacity of 100,000 gallons (150% of the primary leachate tank) under Building Permit MI 176258.

**EXHIBIT D - Compliance Status Table: Keller Canyon Landfill Land Use Permit 2020-89 Conditions of Approval**

Condition	Condition Description	Compliance Status	Comments
17.17	<p><b>Working Face.</b> The Landfill operator shall maintain a maximum daily working face of 3 acres or less in order to minimize surface water infiltration to the refuse, as well as to control dust and erosion, prevent vector proliferation, and minimize visual impacts. Exceptions to this limitation may be granted in response to natural disasters or other emergencies if deemed to be warranted by the Director of Conservation and Development.</p>	In Compliance. On-Going	Standard operating procedures limit the maximum daily working face to fewer than 3 acres as specified in this condition, and a maximum of 1 acre as specified in Condition 17h of the SWFP.
18.1	<p><b>Surface Water Protection Objective.</b> The Landfill shall not impair the beneficial uses of water bodies in the vicinity of the Landfill site.</p>	Objective	<p>This is solely an Objective. See Conditions 18.2 - 18.5.</p> <p>The original Surface Water Management and Sediment Control Plan was included in FDIP, Sections 4.1 through 4.3. Requirements for surface water protection are also defined in the facility WDRs Prohibitions 8(a), and Specifications B.3, B.7, and B.9.</p>
18.2	<p><b>Surface Drainage System.</b> The Landfill operator shall install and maintain a Landfill surface drainage system which shall be designed to meet State Class II standards. It shall accommodate a 1,000-year, 24-hour design storm, as specified by the County Public Works Department and the San Francisco Regional Water Quality Control Board (SFRWQCB). The drainage system shall convey surface water around the active fill area without contacting the working face or any solid waste. The surface drainage system shall be approved by the SFRWQCB and the County Department of Conservation and Development and included in the Development and Improvements Plan. Surface flow shall be evaluated further with groundwater levels and precipitation factors prior to construction, and findings incorporated into the final landfill design in order to lessen impacts to surface water flow. Flow rates and groundwater levels shall be monitored through the life of the landfill. If loss of surface flow is determined to have unforeseen impacts, a like amount of water shall be provided.</p>	In Compliance. On-Going	<p><b>UPDATE: A portion of the surface drainage system was reconfigured south of the existing "check structure" as part of site development, and in accordance with the Design Report for Phase 3B1 approved by the RWQCB.</b></p> <p>Included in FDIP, Section 4.1. Also see WDRs Finding 18, Spec 2-3, Drawings 29-31. The surface drainage system was designed, constructed, and is maintained in accordance with this condition and requirements of WDR Specification B.3, which requires that surface drainage from tributary areas, and internal site drainage from surface and subsurface sources, shall not contact or percolate through wastes during disposal operations or during the life of the site. Surface drainage from tributary areas, and on-site drainage from surface sources, are collected using surface drainage ditches, and/or other conveyance and collection methods.</p> <p>Letter of authorization from the RWQCB was substantiated by Community Development Department on 10/23/1991. See CDD Memo, V. Conklin to C. Zahn, dated 10/15/1991, and as updated through 10/25/1991. See correspondence from CDD to the District II Supervisor dated 4/22/1992 explaining how landfill design would help control flows into the City's storm drain.</p>
18.3	<p><b>Creek Protection.</b> The landfill shall be designed so leachate and other contaminated water does not flow into Lawlor Creek. See Section 23.3.</p>	In Compliance. On-Going	<p>Landfill site design in the FDIP, the original RWQCB for construction of a Class II landfill, and on-going design reviews by regulatory agencies ensure that neither leachate nor contaminated water flows into Lawlor Creek. The Extent of Waste Placement where waste is disposed is located hundreds of feet away from Lawlor Creek.</p> <p>See RWQCB letter from L. Kolb to B. Olney dated 10/23/1991.</p>

**EXHIBIT D - Compliance Status Table: Keller Canyon Landfill Land Use Permit 2020-89 Conditions of Approval**

Condition	Condition Description	Compliance Status	Comments
18.4	<p><b>Surface Water Management and Sediment Control Plan.</b> The Landfill developer shall prepare and implement a Surface Water Management and Sediment Control Plan, which shall be subject to the approval of the County Department of Conservation and Development. The plan shall include a Stability Analysis of proposed cut and fill slopes, and shall prevent substantial erosion on slopes on the project site and reduce the amounts of water-borne materials from reaching surface waters. It shall include the components listed below, and it shall be included in the Final Improvements and Development Plan.</p> <p>a) Primary Grading. The Landfill developer shall perform primary grading for the project's fill modules, cover, roads, paved areas, building sites, and the construction of site slopes during the April through October low rainfall season.</p> <p>b) Temporary Flow Restriction. If grading must be done during rainy periods, or if erosion is occurring on previously graded areas, the Landfill developer shall take corrective actions, which may include the installation of ground cloth or the placement of hay bales.</p> <p>c) Ground Cover. The Landfill developer shall plant ground over on graded areas which are not to be developed within 90 days. The ground cover shall be consistent with the Landscaping Plan.</p> <p>d) Ditch/Swale Liners. The Landfill developer shall line any ditches and swales for conveying surface runoff across sanitary landfill areas to limit water infiltration. Drainage-ways across other areas shall be lined or planted to limit erosion.</p> <p>e) Sedimentation Ponds. The Landfill developer shall install and maintain a sedimentation pond system prior to other landfill development to hold and process drainage from the Landfill property which shall be designed to withstand the 1,000-year, 24-hour design storm and Maximum Credible Earthquake event. The Landfill developer shall develop a program for monitoring storage volumes in the sedimentation ponds and releasing water depending on expected rainfall. Flow rates for down-stream discharge shall not exceed the 25-year, 24-hour design storm. The program shall include a preventive maintenance program which shall include a program for clearing of sedimentation ponds and maintenance of perimeter ditches and vegetative cover. The owner shall submit documentation to the Department of Conservation and Development to demonstrate that basin maintenance (e.g. dredging) has been completed as needed or required prior to the start of the rainy season (October 15th). The program shall be subject to approval from the County Department of Conservation and Development, Contra Costa Environmental Health, Public Works Department, and the San Francisco Regional Water Quality Control Board. The efficacy of the Landfill surface water control system in reducing downstream flooding shall be addressed in the annual and triennial reviews required by Condition 11.1.</p> <p>f) Runoff Conveyance. Erosion to ditches or gullies used to convey runoff shall be corrected by use of appropriate</p>	Completed. On-Going	<p>The original Surface Water Management and Sediment Control Plan i included in FDIP, Section 4.2 and Appendix I, The RWQCB approved the design for Keller Canyon, (See RWQCB letter from L. Kolb to B. Olney dated 10/23/1991). Plan elements have been updated as needed to meet requirements of landfill construction and prevailing regulations.</p> <p>All requirements in this condition for design and construction of the landfill were met prior to, or if approved by the County, subsequent to landfill opening. Monitoring of surface water management and sediment control is performed in accordance with RWQCB requirements, and Condition 17k(b) of the SWFP.</p> <p>Facility is in compliance with measures incorporated into the WDRs (RWQCB Order 01-040) [e.g. Specification B.2 (Washout and Erosion of Wastes), and B.3 (Management of Surface Drainage), B.7 Final grading promoting lateral runoff] and Provision C.3 (Preparation of facilities prior to rainy season)]. Measures are also incorporated into NPDES Industrial Discharge permit. WDRs and NPDES are monitored and enforced by the RWQCB.</p> <p>See Health Services Department Memo, C. Nicholson to C. Zahn (CDD), dated 10/24/1991. See also Community Development Department Memo, V. Conklin to C. Zahn, dated 10/15/1991, as updated through 10/25/1991.</p>

**EXHIBIT D - Compliance Status Table: Keller Canyon Landfill Land Use Permit 2020-89 Conditions of Approval**

Condition	Condition Description	Compliance Status	Comments
18.5	<p><b>Monitoring.</b> The Landfill developer shall prepare and implement a surface water monitoring program to check for possible contamination of off-site surface water drainage facilities. Baseline water quality shall be determined prior to project implementation. Sedimentation pond outflow shall be monitored. The monitoring program shall be subject to approval of Contra Costa Environmental Health, the County Conservation and Development Department, and the Regional Water Quality Control Board.</p>	Completed. On-Going	<p><b>UPDATE:</b> Storm water discharge monitoring results are summarized in the report titled "Annual Report for Storm Water Discharges Associated with Industrial Activities at Keller Canyon Landfill (WDID No. 2071006887", dated June 2015. The facility Storm water Pollution Prevention Plan (SWPPP) was updated in 2014 to comply with requirements specified in the new General Permit for Storm Water Discharges Associated with Industrial Activities 2014-0057-DWQ.</p> <p>Included in FDIP, Section 4.3. Also see WDRs Self-Monitoring Program. No events of contamination of off-site surface water drainage facilities have occurred. Monitoring of surface water is performed in accordance with the WDRs Item 36. Surface Water. Stormwater discharges from the site are monitored at five locations, during two major storm events, as required by the State Board's General Permit for Stormwater Discharges Associated with Industrial Activities and the Discharge Monitoring Program in Order 01-040.</p> <p>The facility is in compliance with measures incorporated into the WDRs (RWQCB Order 01-040) [e.g. Specification B.2 (Washout and Erosion of Wastes), and B.3 (Management of Surface Drainage), B.7 Final grading promoting lateral runoff] and Provision C.3 (Preparation of facilities prior to rainy season)]. Measures are also incorporated into NPDES Industrial Discharge permit. WDRs and NPDES are monitored and enforced by the RWQCB.</p> <p>See Health Services Department Memo, C. Nicholson to C. Zahn (CDD), dated 10/24/1991, and Community Development Department Memo, V. Conklin to C. Zahn, dated 10/15/1991, and as updated through 10/25/1991.</p>
19.1	<p><b>Hazardous Waste Ineligible.</b> See Section 6.4.</p>	Cross-Reference	<p>This condition solely cross-references another LUP condition. See Condition 6.4.</p>
19.2	<p><b>Load Inspection.</b> See Condition 7.1</p>	Cross-Reference	<p>This condition solely cross-references another LUP condition. See Condition 7.1.</p>

**EXHIBIT D - Compliance Status Table: Keller Canyon Landfill Land Use Permit 2020-89 Conditions of Approval**

Condition	Condition Description	Compliance Status	Comments
19.3	<p><b>Household Hazardous Waste Program.</b> The Landfill operator shall develop a household hazardous waste collection and management program for the service area which is consistent with the County Hazardous Waste Management Plan and with the County Integrated Solid Waste Management Plan. The program shall be subject to the approval of the Contra Costa Environmental Health and Conservation and Development Departments. The household hazardous waste shall be managed in accordance with the "Waste Minimization Hierarchy" identified in the County Hazardous Waste Management Plan. The operator is encouraged to develop the program in cooperation with other waste management facilities and collection services. The proposed program, along with a schedule of proposed costs and funding sources, shall be submitted to the County departments no later than 6 months prior to the opening of the landfill. The program shall include mechanisms for removing household hazardous waste from the waste stream which arrives at the facility. If the household hazardous waste program (or a version of it) is approved by the County Board of Supervisors, the Landfill operator shall implement it. The Landfill household hazardous waste program shall include a public information and education program approved by the Contra Costa Environmental Health/County Hazardous Materials Commission for notifying facility users and households in its service area of what constitutes hazardous waste and how such wastes are to be disposed of. The household hazardous waste program shall be amended if required by the County Board of Supervisors in their review of the Land Use Permit.</p>	Not Yet Required	<p>This condition preceded the approval of the County's Household Hazardous Waste (HHW) Element of the Countywide Integrated Waste Management Plan. There was a substantial change in public policy with respect to management of this portion of the waste stream shortly after this LUP was approved. CDD advised the Board of Supervisors that this policy change effectively put this COA 19.3 "on hold." (see memo from H. Bragdon to the Board of Supervisors dated 4/28/1992).</p> <p>By early 1992, County HSD had taken the lead role in implementing a countywide mobile collection program. Several years later wastewater agencies developed and began operating permanent drop-off facilities for HHW to serve those living in Central (Central Contra Costa Sanitary District) and East County (Delta Diablo Sanitation District). Soon thereafter a permanent drop-off facility was built in North Richmond to serve West County.</p> <p>The countywide household hazardous waste program includes three permanent HHW facilities serving households in their respective areas to provide free and convenient option to properly manage HHW effectively removing it from the waste stream before it reaches the landfill.</p> <p>The Countywide Integrated Waste Management Plan approved in 1993 does not call for an HHW program at Keller Canyon Landfill, however such a program could be re-activated if conditions change.</p>
19.4	<p><b>Hazardous Waste Pre-screening.</b> The landfill entrance load screening procedures and a manual load check program during unloading operations shall be included in the load screening program required under Condition 7.1. Landfill employees shall be instructed to investigate suspicious containers for hazardous materials during bulldozing and other activities. Any hazardous materials found shall be set aside for proper collection and disposal.</p>	In Compliance. On-Going	<p><b>UPADTE: The Eligible Vehicles and Loads program that is implemented at the landfill scale house was updated in 2013 and approved by the LEA in 2014.</b></p> <p>A Load Check program and hazardous waste pre-screening program are in effect at Contra Costa Transfer and Recovery Station and other transfer stations that dispose of waste at Keller Canyon Landfill. (See Condition 7.1)</p>
19.5	<p><b>Regulatory Agency Approvals.</b> The collection and storage of toxic and hazardous wastes pursuant to this section shall be subject to County Health Services Department's Hazardous Materials Division, State Department of Health Services, and other regulatory agency approvals.</p>	In Compliance. On-Going	<p>Condition Acknowledged. Procedures related to storage of toxic or hazardous waste are also addressed in SWFP 07-AA-0032, Section 17j. Should this statement also be included in the compliance response for the condition above? DB: This statement belongs in the comments for COA 19.5</p>
20.1	<p><b>Prevention of Air Quality Deterioration.</b> The Landfill operator shall manage the facility in a manner that does not result in the significant deterioration of air quality in the vicinity of the site or in the Bay Area. The condition shall be interpreted as a requirement that the Landfill comply with terms of the Authority to Construct Permit to Operate permits issued by the Bay Area Air Quality Management District.</p>	In Compliance. On-Going	<p><b>UPDATE: The new version of the Title V Major Facility Review Permit #A4618 was issued by the BAAQMD on March 17, 2016. Landfill owner/operator compliance with conditions of approval in LUP Section 20. The landfill facility is in compliance with all permits issued by the BAAQMD. Title V Permit Major Facility Review Plant No. A4618 last issued March 17, 2016; and the Authority to Construct/Permit to Operate Plant No. A4618. The Authority to Construct/Permit to Operate is reviewed annually by the BAAQMD.</b></p> <p>The Landfill Gas Management/Air Quality Monitoring/Odor Control Plan is included in the FDIP, Sections 8.1 through 8.10. The original Authority to Construct is Appendix B of the FDIP.</p> <p>The landfill facility <b>has established</b> protocols for logging complaints <b>and handling those types of communications (see below).</b></p>



Condition	Condition Description	Compliance Status	Comments
20.2	<p><b>Odor Containment.</b> The Landfill operator shall operate the Landfill in a manner that prevents odors from being detected off-site, pursuant to Regulations 7-101 and 7-102 of the Bay Area Air Quality Management District. If odors are reported to Contra Costa Environmental Health, or reports are relayed from the Bay Area Air Quality Management District, the Department of Conservation and Development or Contra Costa Environmental Health may require additional physical improvements or management practices as necessary to alleviate the problem. Contra Costa Environmental Health shall have the authority to cease disposal at a particular area of the Landfill, to control odors. A small daily working face (3 acres or less) shall be maintained. The leachate treatment system shall be enclosed and properly maintained to control odors from leachate. The landfill gas collection system and flare shall utilize BACT to reduce landfill gas as a source of toxics and odor.</p> <p>The Landfill operator shall implement Best Management Practices of the industry to minimize odors from operations and emissions from equipment. If the operator is contacted about odors being detected off-site, the date, time and description of the odor complaint shall be logged and investigated promptly to expedite implementation of any necessary corrective action by the landfill operator. The Landfill operator shall contact Contra Costa Environmental Health or the Bay Area Air Quality Management District at minimum of once per year to obtain any information possible about odor complaints received by each agency. Any odor complaints received by the Landfill operator, Contra Costa Environmental Health or the Bay Area Air Quality Management District shall be included in the annual Activities Report required under the Landfill's Franchise Agreement unless otherwise specified by the Director of Conservation and Development. The landfill operator shall provide a means for receiving after hours odor complaints. Complaints shall be promptly investigated (after hours investigations required if/when multiple after hours complaints received on the same day or on multiple consecutive days) to identify whether the source of the odor is on the landfill site, in which case the problem should be corrected in a timely manner. A response to the person lodging the complaint shall be made within 48 hours and copied to the Department of Conservation and Development, detailing the problem and remedial action taken.</p>	In Compliance. On-Going	<p>UPDATE: Complaint data reviewed in this LUP compliance review were provided by the BAAQMD, DCD, and CCEH. The KCL Odor Complaint Log maintained at the landfill was also reviewed.</p> <ul style="list-style-type: none"> <li>* Each complaint received has a date and approximate time of occurrence. Several complaints do overlap with another agency when an odor complaint is received independent of KCL staff.</li> <li>* 55 odor complaints were recorded from January 2015 – August 2016. None were confirmed.</li> <li>* The BAAQMD recorded 37 complaints; KCL: 27, DCD: 15, and CCEH: 9. The comparatively low number of recorded complaints with CCEH reflects its policy to not investigate anonymous complaints that do not provide a physical address.</li> <li>* DCD set up a Complaint Form on its website in early 2015 that allows an electronic submittal of an odor complaint. An email alert is simultaneously sent to CCEH and KCL.</li> <li>* 80% of the odor complaints were recorded from January through April, coinciding with the rainy season. These odor complaints were described generally as "dirty diapers" to "manure" to "garbage."</li> <li>* KCL has procedures for identifying, evaluating, and mitigating off-site odors when they are confirmed. Site personnel routinely patrol the area including local neighborhoods for any indication of odors. Findings and results from the surveys are documented daily. All complaints submitted to KCL, whether by phone, or a referral by DCD or BAAQMD, are followed up and investigated by KCL staff. All complaints are tracked and reviewed. Where feasible, complainants or nearby neighbors were interviewed.</li> <li>* Investigations usually involved follow-up by KCL staff, or jointly with BAAQMD and/or CCEH.</li> <li>* The on-site KCL weather station data are reviewed to assess wind direction and speed at the approximate time of the odor complaint.</li> <li>* Additionally, KCL has systems and operation practices to minimize odor impacts on the surrounding community, including use of Best Available LFG Control Technology, maintaining a small working face (less than 1 acre in size) and enclosing the leachate system.</li> </ul> <p>An odor impact minimization plan (OIMP) is in effect. An Odor Complaint Program is also in effect per Condition 17k(g) of the SWFP. Odor complaints and associated responses/corrective actions are logged in the facility's Complaint Log. Standard forms record the date of the complaint, name of the individual filing the complaint (if available), weather conditions, name of the landfill complaint investigator, the alleged locations of odors, and the results of complaint verification by either landfill personnel or personnel from the LEA or BAAQMD. Incidents are also recorded in a Log of Special Occurrences pursuant to provisions of Title 27 CCR 20510 (c) per Condition 17o of the SWFP. Follow up actions by the landfill are also documented in the annual Activities Report submitted to DCD.</p>

**EXHIBIT D - Compliance Status Table: Keller Canyon Landfill Land Use Permit 2020-89 Conditions of Approval**

Condition	Condition Description	Compliance Status	Comments
20.3	<p><b>Cover Frequency.</b> The Landfill operator shall cover newly disposed refuse with compacted soil or other cover material meeting state regulatory requirements enforced by Contra Costa Environmental Health and CalRecycle and approved in writing by the Department of Conservation and Development. All working faces of the Landfill shall be covered by the end of the working day. Intermediate cover, meeting the requirements of the State shall be applied over each layer of cells ("lift"). The type of cover material and frequency of cover shall be modified in order to control odor, litter or birds, if necessary, or if required by the Director of Conservation and Development or the Landfill's Solid Waste Facilities Permit.</p>	In Compliance. On-Going	<p><b>UPDATE:</b> CCEH approved KCLC to use green waste and geosynthetic blankets as Alternative Daily Cover (ADC) after conducting a one-year demonstration project back in 1999-2000 and included a summary report, dated 6/28/2000. The use of greenwaste as ADC was approved shortly after the acceptance of the results of the demonstration project. The landfill's RDSI was updated in early 2015 to formally reflect additional details regarding the use of unprocessed green waste as ADC. The decision to approve that RDSI amendment was appealed to CalRecycle by an outside party. In August 2015, CalRecycle denied the appeal and upheld the approval of the RDSI amendment. As a result, the outside party filed a law suit against CalRecycle (State) and that case is still pending.</p> <p>In September 2014, Governor Brown signed Assembly Bill (AB) 1594 mandating that as of January 1, 2020, the use of green material as alternative daily cover (ADC) will no longer constitute diversion through recycling and will instead be considered disposal in terms of measuring a jurisdiction's annual 50 percent per capita disposal rate.</p> <p>All requirements for approved daily cover materials and practices are complied with as standard operating procedure. Soil cover frequency is in accordance with requirements of LUP Condition 20.3, procedures of the SWFP, and Condition #17309 part 3(a) through 3(d) of the Major Facility Review permit issued by the BAAQMD. The Working Face is limited to 1.0 acre under Condition 17h of the SWFP. Also see Condition 20.2, 24.4 Bird Control, and Section 25 Litter Control.</p>
20.4	<p><b>Odoriferous Loads.</b> The Landfill operator shall identify potentially odoriferous loads prior to acceptance and make any arrangements needed to ensure that disposal of odoriferous loads is managed to avoid off-site detection, which may involve covering such incoming loads immediately.</p>	In Compliance. On-Going	<p>Immediate covering of odoriferous loads is standard operating procedure in accordance with requirements of this LUP, the SWFP, and BAAQMD Major Facility Review permit Condition #16462 regulating the handling, use, and storage of yard and green waste stock piles. Air District requires that certain details about the green waste stockpiles be included in each semi-annual report (available on the BAAQMD website).</p>
20.5	<p><b>Dust Suppressants.</b> The Landfill operator shall apply water or proven environmentally safe dust suppressants at least twice daily to working faces of the landfill, unpaved access roads, storage pile disturbances and construction areas as determined to be necessary by Contra Costa Environmental Health. Contra Costa Environmental Health may require sprinklering more frequently for control of particulates.</p>	In Compliance. On-Going	<p><b>UPDATE: Condition #17309, Item 8, of the BAAQMD permit states that water and/or magnesium chloride is to be applied depending on season: "Except as provided below, all applications of dust suppressant shall consist of 0.5 gallons per square yard of 10% MgCl2 applied along the entire length of all unpaved roads."</b></p> <p>The facility is in compliance with dust suppression measures implemented per this LUP condition, Condition 17k(d) of the SWFP, and Condition #17309 and #16462, parts 8(a) through 8(d), 9, 10, 13, 15, and 16(j) through 16(l) of the Major Facility Review permit issued by BAAQMD.</p>
20.6	<p><b>Area of Operations.</b> See Conditions 17.17 and 22.10.</p>	Cross-Reference	<p>This condition cross-references to other LUP conditions. See Conditions 17.17 &amp; 22.10.</p>

**EXHIBIT D - Compliance Status Table: Keller Canyon Landfill Land Use Permit 2020-89 Conditions of Approval**

Condition	Condition Description	Compliance Status	Comments
20.7	<p><b>Air Flow Monitoring.</b> The Landfill operator shall monitor air flow on the site upon commencement of operations and shall provide background meteorological conditions including wind direction, wind velocity, and temperature. After the Landfill is in operation, data shall be used to correlate odor, dust, or litter management with meteorological conditions. Air flow monitoring reports shall be submitted or made available to the Contra Costa Environmental Health and the Department of Conservation and Development upon request.</p>	In Compliance. On-Going	<p><b>UPDATE: The landfill weather monitoring station has been in continuous operation. The system is a Vantage Pro2 by Davis Instruments with Weatherlink analytical and reporting software. The collected data are stored on a secure server, thus weather conditions can be reviewed and analyzed for virtually every day the system has operated and stored this data. Collected data are also used to assist in the evaluation of odor complaints. Specifically, weather parameter of wind direction and speed, precipitation, relative humidity, and outside temperature are recorded as needed to evaluate odor complaints.</b></p> <p>An expanded weather monitoring station was installed May 1997 that monitors and records all meteorological conditions specified in this LUP condition. Data are used to manage daily landfill operations. CCEH letter dated 12/8/1995 acknowledges that their office and DCD agreed that KCL would not be required to submit actual monitoring reports unless determined necessary in the future. Data is available for review by regulatory agencies upon request and periodically checked by LEA during their routine inspections.</p>
20.8	<p><b>Contingency Program.</b> Prior to the start of filling operations, Landfill operator shall prepare a "bad days" contingency program for managing the Landfill during periods of unusual wind speeds or directions, rainfall or drought or other atypical situations. It shall apply specific site monitoring information. The Landfill operator shall consider the comments of the City of Pittsburg and consult with the Bay Area Air Quality Management District and the Regional Water Quality Control Board. The program shall be approved by the Department of Conservation and Development and Contra Costa Environmental Health, and it may be revised from time to time. See Condition 25.4.</p>	Completed. On-Going	<p>The landfill operator has established procedures for dealing with inclement weather with the potential to hamper normal operations. Rain and/or high winds may require adjustment of on-site waste handling and disposal procedures. During prolonged heavy rains, operations are moved to a tipping area (wet weather area) which has been surfaced with asphalt grindings to provide all weather access to allow for continuous refuse disposal operations during inclement weather. Stockpiles of soil material are maintained near the designated wet weather alternative tipping area to provide an adequate supply of cover material. Normal traffic and vehicle access to the wet weather area is provided by paved and/or a combination of tightly compacted soil and asphalt grindings.</p> <p>For high wind conditions, the unloading area is typically reduced in size and, whenever possible, placed in a portion of the landing that affords protection from the wind. Additional equipment may be utilized to expedite the spreading and compacting of the refuse as soon as it is unloaded. Cover operations may also be implemented prior to the end of the working day to reduce the area of exposed refuse on the working face. In addition, portable litter fencing is in-place and is used downwind around the unloading areas.</p>
20.9	<p><b>Revegetation.</b> The Landfill operator shall revegetate completed Landfill areas. Revegetation shall be in accordance with the Development and Improvements Plan and shall be consistent with State and local water conservation landscaping requirements. Intermediate and final cover areas shall be reseeded with native grasses immediately. Excavations shall be reseeded with native grasses or filled immediately. Operating areas which will not be used for fill or construction for 90 days or longer shall be planted for dust and erosion control and for aesthetic purposes. Landfill operator shall provide the County Conservation and Development Department with written notice and documentation (e.g. photographs) of any inactive unvegetated areas of disturbance not being reseeded immediately whether due to on-site activity associated with the landfill (construction or operations) or naturally occurring (landslides, etc.). The Director of Conservation and Development may require that revegetation notices be submitted more frequently and/or on a fixed schedule.</p>	In Compliance. On-Going	<p>Included in FDIP, Sections 7.1 and 8.1 and Appendix E. Revegetation measures of graded areas are in compliance with Condition #17309 Part 14 of the Major Facility Review permit issued by BAAQMD, and is standard operating procedure when such areas are not expected to be used for fill or construction within 90 days or longer.</p>

**EXHIBIT D - Compliance Status Table: Keller Canyon Landfill Land Use Permit 2020-89 Conditions of Approval**

Condition	Condition Description	Compliance Status	Comments
20.10	<p><b>Tree and Shrub Planting.</b> The Landfill developer shall plant trees and shrubs downwind of the Landfill to aid in trapping dust. The planting plan shall be included in the Landscaping plan component of the Development and Improvements Plan.</p>	Completed	The tree and shrub planting plan is included in FDIP, Section 8.2, Landscape Plan drawings LP-1, LP-2, and LP-3. Tree and shrub planting species and locations were approved in the Landscaping Plan. See COA 22.2
20.11	<p><b>Gas Control and Collection.</b> The Landfill operator shall install a Landfill gas control collection system in accordance with the regulations of the Bay Area Air Quality Management District. The system shall have the capacity to operate in an active mode, using a mechanical vacuum, to withdraw gas from the Landfill. The system shall be operated in an active mode as soon as practical. The gas control and collection system shall be installed concurrently with the placement of wastes in the Landfill and shall be ready for operation when gas is produced. The gas collection and related recovery system shall utilize BACT and shall be subject to the approval of the Bay Air Quality Management District and County Conservation and Development Department and it shall be included in the Development and Improvements Plan.</p>	Completed. On-Going	<p><b>UPDATE: Due to the progression of waste filling activities, 17 additional vertical extraction wells and associated piping were installed in 2015. All construction activities were conducted in compliance with KCL's Permit To Operate issued by the Bay Area Air Quality Management District. Construction activities included installation of additional vertical extraction wells, an above and below ground header pipe line, and additional lateral pipe lines. The annual collection system improvements made in 2014, 2012, 2011, 2009, and 2008 has increased gas collection and operating efficiency.</b></p> <p>Included in FDIP, Section 8.3.</p> <p>Gas control and collection requirements are contained in BAAQMD Major Facility Review permit Condition #17309 Parts 18 through 30. Facility components for gas control and collection (Flares 1 and 2) are permitted abatement devices A-1 and A-2, and active gas collection is source S-1. The landfill gas control system did not have to become operational until one million cubic yards of refuse had been placed in the landfill.</p> <p>KCL manages a complex landfill gas (LFG) collection system consisting of vertical extraction wells, headers, and sub-headers. The LFG collection system is under vacuum which draws the landfill gas to a central point currently consisting of a flare station, a blower building, and a landfill gas-to-energy facility (LFGTE). The LFG collection system, including additional vertical collection wells and flares, will be expanded as the landfill is developed to provide ongoing control within the performance criteria established and mandated by the BAAQMD and State and federal regulations.</p>
20.12	<p><b>Landfill Gas Processing.</b> The Landfill developer shall install a flaring mechanism, in accordance with Bay Area Air Quality Management District guidelines/regulations, to combust collected landfill gas. The flare shall be of the nonilluminous type. Best Available Control Technology (BACT) shall be used, as defined and approved by the Bay Area Air Quality Management District. The flare shall be installed with staged combustion, operated under fuel-rich conditions, and be designed with flue gas recirculation.</p>	Completed. On-Going	<p>The original design for the flare system was included in FDIP, Section 8.4 and Appendix D. See Community Development Department letter from C. Zahn (CDD) to S. Gordon, dated 10/24/1995. Two flares are in operation that are subject to performance standards and testing requirements in Condition #17309 Parts 20 through 30 of the Major Facility Review permit issued by the BAAQMD.</p> <p>There are two enclosed flares constructed in the Landfill Gas Management and Landfill Gas to Energy Facilities area. The first flare was installed at KCL in 1995. Flare #2 was installed in 2007 to act as both a backup unit and to provide additional capacity as LFG production increases at the site.</p> <p>Both flares are 40-ft. high insulated steel tubes equipped to control combustion of the LFG to destroy methane and other <b>gases</b>. Both flares are founded on a reinforced concrete slabs and are designed to withstand conservative seismic and wind loads. In 2007, a new control system was installed that integrates control of both flares to a single system, allowing either one or both flares to operate, depending on LFG destruction needs. This new control system also interfaces with the LFGTE plant to ensure that consistent LFG extraction and destruction is maintained. See Condition 20.13.</p>

**EXHIBIT D - Compliance Status Table: Keller Canyon Landfill Land Use Permit 2020-89 Conditions of Approval**

Condition	Condition Description	Compliance Status	Comments
20.13	<p><b>Methane Recovery.</b> The Landfill operator shall install a methane recovery system simultaneously with the construction of the gas collection system, preferably utilizing the Landfill gas to produce energy when the Landfill has developed enough gas to justify recovery. When required by the County Community Development Department, the Landfill operator shall conduct a study to determine how methane could be recovered from the gas and used for fuel or as a commodity.</p>	Completed. On-Going	<p>An early plan for methane recovery was included in the FDIP, Section 8.5.</p> <p>In 2006, Ameresco, Inc. submitted a development proposal to the County for a power plant with a capacity of up to 3.8 MegaWatts, which was ultimately approved. The landfill gas to energy (LFGTE) power plant was dedicated in October 2009 under County file #LP012115, a previous LFGTE project that was approved but never built on-site. The plant is owned and operated by Ameresco Keller Canyon L.L.C. See Section 36 of this LUP.</p> <p>The LFGTE plant was constructed adjacent to the existing flare station described in Condition 20.12 above. Ameresco has secured a power purchasing agreement to sell the power generated at KCL. See Section 36 Landfill Gas Power Plant of this LUP.</p>
20.14	<p><b>Gas Monitoring.</b> The Landfill developer shall install gas migration detection probes and wells along the boundary of the Landfill footprint, near on-site buildings, and in other locations specified by the Bay Area Air Quality Management District or Contra Costa Environmental Health to monitor for subsurface and surface gas migration. The gas monitoring stations shall be described in the Development and Improvements Plan approved by the County Conservation and Development Department. If gas migration is found, the Landfill operator shall notify the County and take remedial actions. Training of employees for detection of gas migration shall be included in the employee training program.</p>	In Compliance. On-Going	<p>Plans for the initial gas monitoring system are included in FDIP, Section 8.6. The monitoring and control of gas emissions via integrated and instantaneous surface emissions monitoring is conducted in accordance with the BAAQMD Rule 34 compliance plan requirements for the KCL. Perimeter probe results from collected monitoring data are compiled into a report. Gas monitoring data is submitted by KCL to the LEA and BAAQMD.</p> <p>As of September 20, 2007 regulations for Gas Monitoring and Control at Active and Closed Disposal Sites became effective. KCL submitted a Landfill Gas Monitoring Migration Monitoring Plan as required by the new regulations in September 2008. The Landfill Gas Migration Monitoring Plan was revised in response to LEA comments and subsequently approved by The LEA on August 3, 2009.</p> <p>Perimeter and surface landfill gas at KCL are monitored in accordance with CFR 258.23 (Subtitle D) and the BAAQMD Regulation 8, Rule 34. Perimeter and surface landfill gas monitoring are conducted on a quarterly basis. Perimeter landfill gas monitoring at the KCL have shown that there is no landfill gas migration off-site. The perimeter landfill gas monitoring probes were designed and spaced according to 27 CCR and BAAQMD requirements, and are in conformance with the criteria set forth in Subtitle D.</p> <p>On-site structures are monitored monthly, in accordance with 27 CCR, Section 20931, for detection of potential landfill gas migrating into building structures. The upper detection limit is 1.25 percent methane by volume.</p>
20.15	<p><b>Lateral Gas Barriers.</b> The Landfill developer shall install a gas barrier or gas collection area on side slopes of the Landfill to prevent lateral gas migration through the sides of the Landfill. The barrier or gas collection area shall be approved by the Bay Area Air Quality Management District and shall be included in the Development and Improvements Plan.</p>	Completed. On-Going	<p>KCL operates a gas collection system on or near the slopes in general, and has installed horizontal collectors at the perimeter of the lining system when the perimeter probes are activated. This portion of the collection system is located only in the northeast corner of the lined area, approximately where the toe berm meets original ground just down hill from the east side liner area. "Barriers" as described in this condition are not in place at Keller. Barriers have not proven effective without significant collection infrastructure to ensure gas does not get diverted and causes a release in a different location. KCL has installed collection systems as needed to maintain compliance with CCR Title 27 (Subsurface) and BAAQMD/USEPA (Near-Surface) emissions requirements. Given the large buffer areas surrounding the landfill operations area, the best approach is to install and maintain a long-term collection system near a trouble area located within the waste mass, to "pull back" the gas.</p>

**EXHIBIT D - Compliance Status Table: Keller Canyon Landfill Land Use Permit 2020-89 Conditions of Approval**

Condition	Condition Description	Compliance Status	Comments
20.16	<p><b>Settlement Protection.</b> The Landfill developer shall use flexible piping and lightweight backfill for the Landfill gas collection system to ensure that settlement of the fill will not affect operation of the system.</p>	Completed. On-Going	<p><b>UPDATE: Test reports for calendar year 2015 and 2016 to-date were submitted to the BAAQMD and County Department of Conservation and Development in accordance with this condition of approval.</b></p> <p>All materials and construction techniques approved by the BAAQMD are utilized to minimize potential settlement of fill. KCL has installed collection systems as needed to maintain compliance with CCR Title 27 (Subsurface) and BAAQMD/USEPA (Near-Surface) emissions requirements.</p> <p>Annual source tests are performed per Condition #17309 parts 30 and 31 of the Major Facility Review permit. Reports are filed with the BAAQMD and are available to interested agencies. The LFGTE power plant source testing is contained in its separate permit with the BAAQMD.</p>
20.17	<p><b>Landfill Gas Testing.</b> The Landfill operator shall test Landfill gas for its toxic composition and for toxic constituents. The testing program shall be subject to the approvals of the Bay Area Air Quality Management District, Contra Costa Environmental Health and the Department of Conservation and Development. The Landfill operator shall provide the results to the County Department of Conservation and Development and Contra Costa Environmental Health on a bi-annual basis unless a more frequent interval is specified in the Solid Waste Facilities Permit.</p>	In Compliance. On-Going	<p><b>UPDATE: Source test reports for calendar year 2015 and 2016 to-date were submitted to the BAAQMD and County Department of Conservation and Development in accordance with this condition of approval.</b></p> <p>KCL conducts a source test at each flare once every year. Source test reports are submitted to the BAAQMD Compliance and Enforcement Division and the Source Test Section within 60 days of the test date. Each annual source test is required to determine specific parameters and constituents of landfill gas as specified in the Major Facility Review permit.</p> <p>KCL also conducts characterization of the landfill gas concurrent with the annual source test required by the above. Landfill gas sample(s) are analyzed for concentrations of carbon dioxide (CO<sub>2</sub>), nitrogen (N<sub>2</sub>), oxygen (O<sub>2</sub>), methane (CH<sub>4</sub>), and total non-methane organic compounds (NMOC) in addition to organic and sulfur compounds specified in Part 31 of the permit with BAAQMD. Test reports are submitted to the BAAQMD Compliance and Enforcement Division and the Source Test Section within 60 days of the test date.</p>
20.18	<p><b>Leachate Disposal.</b> See Condition 17.10.</p>	Cross-Reference	<p>This condition solely cross-references another LUP condition. See Condition 17.10.</p>
20.19	<p><b>Cell Re-Opening.</b> Previously-closed cells shall not be reopened without permission from Contra Costa Environmental Health. The Department of Conservation and Development shall be notified of any occurrence that potentially necessitates that one or more cells be re-opened.</p>	In Compliance. On-Going	<p>The facility is in compliance with this condition. Re-opening of cells is reviewed on case-by-case basis and only on approval by CCEH.</p>
20.20	<p><b>Fissure Repair.</b> The Landfill operator shall inspect the Landfill daily. Surface cracks, fissures, eroded areas, or inadequately covered areas on the Landfill may require repairs within 24 hours. The Department of Conservation and Development shall be notified in writing at the time the operator identifies any substantial surface cracks or fissures requiring repairs beyond the placement and compaction of additional clean soil. Photo of the crack should accompany the written notice which describes the expected cause and corrective action plans and repair schedule. This activity shall be included in the employee training program</p>	In Compliance. On-Going	<p>Employees are trained in inspections for fissures and approved repair measures. Staff routinely inspects the Landfill's surface for fissures. Fissures are repaired as they are discovered. When found, fissures are filled with soil and thoroughly compacted.</p>

**EXHIBIT D - Compliance Status Table: Keller Canyon Landfill Land Use Permit 2020-89 Conditions of Approval**

Condition	Condition Description	Compliance Status	Comments
20.21	<p><b>Permanent Road Paving.</b> The Landfill developer shall pave and maintain permanent access roads to control dust. A road used for one year or longer shall be considered to be a permanent road. Road construction shall be described in the Development and Improvements Plan.</p>	In Compliance. On-Going	Plans for permanent road paving are included in FDIP, Sections 8.8 and 8.9, Drawings 10 and 11. All roads designated for permanent paving have been completed and are maintained per this LUP and Condition #17309 Part 4 of the Major Facility Review permit issued by the BAAQMD.
20.22	<p><b>Temporary Road Paving.</b> The Landfill developer shall pave and maintain temporary road with gravel or crushed aggregate. Temporary roads shall be wetted or chemically treated when necessary to control dust. Road construction shall be described in the Development and Improvements Plan.</p>	In Compliance. On-Going	<p>Plans for temporary paving are included in the FDIP, Section 8.9. Major Facility Review permit Condition #17309 Part 5(a) through 5(d) identifies five temporary roadway segments comprising haul roads to the Working Face and a secondary fire access road. Temporary paving material consists of a minimum of 12 inches of compacted gravel or crushed asphalt.</p> <p>The facility is in compliance with dust control measures of Major Facility Review permit Condition #17309 Parts 8(a) through 8(d), Part 9, Part 10, and Part 13 pertaining to control measures to be implemented depending on type of road, landfill vehicle traffic, and weather.</p>
20.23	<p><b>Speed Limits.</b> The Landfill operator shall enforce speed limits set by the Contra Costa Environmental Health on internal site roads. The Landfill operator shall install appropriate signs and speed control devices. The maximum internal on-site speed limit shall be 20 mph unless otherwise specified by Contra Costa Environmental Health.</p>	In Compliance. On-Going	Posted speed limit for paved roads is 15 mph; speeds on unpaved roads and fire roads are limited to 10 mph and 25 mph, respectively, per Condition #17309 Part 6 of the Major Facility Review permit. Signs are installed and speed limits are enforced.
20.24	<p><b>Equipment Maintenance.</b> The Landfill operator shall maintain Landfill equipment in optimum working order to ensure that vehicle emissions are controlled and equipment shall be fitted with spark arrestors so potential for causing fires is minimized. Equipment shall not be left idling when not in use. Maintenance records shall be kept on all pieces of Landfill equipment. The records are subject to review by Contra Costa Environmental Health. Equipment shall be stored, serviced, and repaired in a maintenance area designated in the Development and Improvements Plan and approved by the County Conservation and Development Department.</p>	In Compliance. On-Going	<p>Equipment maintenance is performed according to manufacturer specifications and at required intervals. Maintenance records are maintained by the operator and available for review by County agencies.</p> <p>All equipment maintenance operations are completed at the landfill. The equipment maintenance facility includes a 6,000 sq. ft. building that contains all equipment spare parts and material storage units for the site equipment maintenance operations (e.g., storage bins and cabinets, waste oil tanks, fuel tanks, water tanks). A maintenance yard is used for scheduled maintenance of heavy equipment including daily routine, minor, and major repairs. All equipment (including stationary equipment) are maintained, tested, monitored, and inspected on a regular basis to ensure that they are functioning and readily available.</p>
21.1	<p><b>Noise Control Objective.</b> The Landfill operator shall manage the facility in a manner that minimizes noise impacts to area residents.</p>	Objective	<p>This is solely an Objective. See Conditions 21.2 - 21.8.</p> <p>Compliance with conditions of approval in LUP Section 21. Noise Control has minimized noise impacts to surrounding residential areas. DCD is not aware of any violations involving noise generated by the landfill.</p>

**EXHIBIT D - Compliance Status Table: Keller Canyon Landfill Land Use Permit 2020-89 Conditions of Approval**

Condition	Condition Description	Compliance Status	Comments
21.2	<p><b>Noise Monitoring Program.</b> The Landfill operator shall prepare and implement a noise monitoring and abatement program, which shall be approved by the County Department of Conservation and Development and Contra Costa Environmental Health. The program shall monitor noise levels at sensitive receptor locations, one West of Bailey Road and South of West Leland Road, one near Bailey north of West Leland, and another in the Jacqueline Drive area south of West Leland Road. The Director of Conservation and Development may specify other monitoring locations. Noise monitoring reports shall be submitted to the County Conservation and Development Department on a quarterly basis unless otherwise specified by the Director of Conservation and Development. If the monitoring noise levels at the Landfill boundary line or other monitored location exceed 60 dBA during daylight hours, or 50 dBA during the evening or at night, the County may require the operator to institute additional noise reduction measures to bring noise emanating from the Landfill to the forementioned levels or less.</p>	In Compliance. On-Going	<p>Noise monitoring is performed monthly and reports are prepared quarterly per the requirements of this condition. No off-site noise impacts have been consistently received since the landfill opened in 1992. Noise monitoring have demonstrated that ambient noise levels during periods the landfill is in operation are below the thresholds established in this condition at the landfill boundary line and other monitored locations. There is no history of consistent off-site noise complaints.</p> <p>See Community Development Department Memo, V. Conklin to C. Zahn, dated 10/15/1991, and as updated through 10/25/1991. Also see Health Services Department Memo from C. Nicholson to C. Zahn (CDD) dated 3/10/1992.</p>
21.3	<p><b>Toe Berm.</b> See Condition 22.3.</p>	Cross-Reference	<p>This condition solely cross-references another LUP condition. See Condition 22.3.</p>
21.4	<p><b>Mitigation/Lift-Level Berms.</b> See Condition 22.4</p>	Cross-Reference	<p>This condition solely cross-references another LUP condition. See Condition 22.4.</p>
21.5	<p><b>Construction Hours.</b> See Condition 32.1.</p>	Cross-Reference	<p>This condition solely cross-references another LUP condition. See Condition 32.1.</p>
21.6	<p><b>Truck Noise Suppression.</b> The Landfill operator shall require transfer trucks and other waste hauling vehicles using the facility to be equipped with factory approved noise suppression equipment, including engine compartment insulation. The Landfill operator shall request the California Highway Patrol actively enforce muffler and vehicle noise standards as required in the California Vehicle Code if, for any reason, noise from heavy trucks becomes a source of complaints in the project area, whether project-related or not. Transfer trucks and other waste hauling vehicles with faulty mufflers shall be denied access to the landfill after one warning by a landfill operator at the landfill entrance.</p>	In Compliance. On-Going	<p>Waste-hauling trucks to KCL are equipped with noise suppression features that are standard to the industry. The landfill operator's transfer trucks are subject to inspection and maintenance as part of the operator's equipment maintenance program. Maintenance is performed according to manufacturer specifications and at required intervals. Faulty mufflers would be replaced as they are identified.</p> <p>No truck noise complaints have been consistently received at the landfill office since the late 1990s. In response to concerns about noise resulting from trucks traveling over speed bumps near the landfill entrance, the landfill operator voluntarily removed the speed bumps. Since that time no complaints of truck noise have been received at the landfill office.</p> <p>The CHP periodically sets up a mobile inspection station outside of the landfill entrance to ensure compliance with vehicle safety and equipment requirements. The landfill operator has not had cause to request enforcement by the CHP.</p> <p>New procedures have been put in place at the Landfill if a truck is determined to have a faulty muffler (or mufflers) by landfill staff at the scale house or working face, the landfill staff shall record the truck tractor license number and date of determination. The operator of the subject truck may be issued a warning to repair the muffler (or mufflers) at the discretion of landfill staff, depending to the degree that muffler performance is believed to be degraded. The truck operator shall be allowed up to 21 days from the date of determination to effect repairs. The truck operator shall be required to provide documentation of repair to the landfill scale house operator to avoid being denied future access to the landfill.</p>



**EXHIBIT D - Compliance Status Table: Keller Canyon Landfill Land Use Permit 2020-89 Conditions of Approval**

Condition	Condition Description	Compliance Status	Comments
21.7	<b>Landfill Vehicles.</b> The Landfill operator shall provide Landfill equipment with the best available noise suppressing equipment to minimize sound generation.	In Compliance. On-Going	Landfill equipment are equipped with best available noise suppressing equipment as supplied by the manufacturer.
21.8	<b>Gas Flare Muffling.</b> If flaring is used to dispose of Landfill gas, the flares shall be contained in noise and glare-reducing housing. The housing shall be subject to the approval of the Contra Costa Environmental Health and Conservation and Development Departments and the Bay Area Air Quality Management District.	Completed. On-Going	Design of the gas flares was approved by the BAAQMD prior to operation, and are operated in accordance with BAAQMD Title V requirements.
22.1	<b>Visual Quality Objective.</b> The Landfill developer shall construct and operate the facility in such a manner that the high visual value of the surrounding area is maintained.	Objective	This is solely an Objective. See Conditions 22.2 - 22.14.  Compliance with conditions of approval in LUP Section 22. Visual Quality has maintained the high visual value of the surrounding area. Landfill site development occurs only in approved areas as defined in the Report of Disposal Site Information, the FDIP, and landfill phase design and construction documents approved by the RWQCB.
22.2	<b>Landscape Plan.</b> The Landfill developer shall prepare and implement a site Landscaping Plan. The plan shall enhance the site's visual values as open space and its functional values as wildlife habitat. It shall minimize the visual impacts of the landfill operations and appurtenant facilities through revegetation and landscape screening. The plan shall show the plant species, size, and locations to be used to blend in with the existing natural vegetation. Natural, drought tolerant species shall be used, in accordance with State and local water conservation landscaping requirements. A landscape maintenance program shall be part of the plan. A Weed Monitoring and Control Program shall be included, containing a listing of noxious weeds, a monitoring program, and abatement measure options. A Landscape Plan shall be included in the Development and Improvements Plan. The Landscape Plan shall assure no visual impact on the Cities of Concord and Clayton consistent with the Environmental Impact Report.	Completed. On-Going	The Landscape (Screening) Plan that included all required elements of this condition is included in the FDIP, Sections 7.1 through 7.3 and Drawings LP-1, LP-2, and LP-3. The Landscape Plan was endorsed by the LAC. Installation of landscaping was phased. The Weed Monitoring and Control Program was included in the Range Management Plan in Condition 23.2 of this LUP. Also see Weed Control Program in Condition 23.5.  See County Letter of acceptance dated 11/2/1992. Also see Community Development Department Memo, V. Conklin to C. Zahn, dated 10/15/1991, and as updated through 10/25/1991.
22.3	<b>Toe Berm.</b> The Landfill developer shall install the first phase of the toe berm prior to other landfill construction and development of the Landfill. Other sections of the toe berm shall be installed in stages (see condition 32.4). The toe berm shall be contoured to blend with existing topography. It shall be designed to screen the landfill access road. It shall be revegetated immediately with native grasses and other vegetation to blend in with the surrounding area.	Completed	Toe berm design is included in FDIP, Sections 3.1 and Drawings 14 & 23. See Community Development Department letter from C. Zahn to T. Cox (KCLC) which authorized construction of the toe berm. Also see Community Development Department letter from C. Zahn to T. Cox (KCLC) dated 12/30/1992 which authorized contouring of the toe berm. Also see Community Development Department memo from H. Bragdon to the Board of Supervisors dated 3/5/1992 which confirmed that the toe berm was constructed properly and keyed to the sub-surface.  The toe berm slope stability analyses approval from the RWQCB and revegetation plan were substantiated by CDD on 10/23/1991. See Community Development Department Memo, V. Conklin to C. Zahn, dated 10/15/1991, and as updated through 10/25/1991.

**EXHIBIT D - Compliance Status Table: Keller Canyon Landfill Land Use Permit 2020-89 Conditions of Approval**

Condition	Condition Description	Compliance Status	Comments
22.4	<p><b>Mitigation Berms.</b> The Landfill developer shall install landscaped mitigation berms (lift-level peripheral berms) at the face of each lift in areas visible off the Landfill site, before beginning refuse disposal on the lift. The berms shall be landscaped to blend with existing terrain. Specific heights for the initial toe berm and each of its phases shall be established in the Final Development and Improvements Plan (Condition 15.1).</p>	Completed. On-Going	The initial toe berm was constructed prior to other landfill construction. Design reports for all phases of site development take into consideration the potential for visual impacts, and are submitted to the County and the RWQCB for review and approval. Lift-level peripheral berms that may be visible from off-site are re-vegetated accordingly.
22.5	<p><b>Lawlor Creek Corridor Plan.</b> See Condition 23.3</p>	Cross-Reference	This condition solely cross-references another LUP condition. See Condition 23.3.
22.6	<p><b>Entrance Screening.</b> The Landfill developer shall install landscaping at the entrance of the landfill to screen the entrance facilities from Bailey Road users. Olive trees shall not be included as part of the entrance landscape plan.</p>	Completed	<p>Design approved by the County subsequent to initial FDIP approval in 1991. All landscaping at the landfill entrance was installed.</p> <p>See Community Development Department Memo, V. Conklin to C. Zahn, dated 10/15/1991, and as updated through 10/25/1991. Also see Community Development Department letter from C. Zahn to T. Cox (KCLC) dated 11/2/1992 which authorized installation of entry streetscape landscaping.</p>
22.7	<p><b>Jacqueline Drive Terminus.</b> The north terminus of Jacqueline Drive shall be landscaped, with native species, to shield near views of the toe berm. Planting of the terminus area shall begin as soon as practicable. The outside access road berm shall be a minimum of 15 feet high to shield transfer truck traffic and noise from nearby residences.</p>	Completed	<p>Completed at the "south" terminus of Jacqueline Drive. Included in landscape design plans approved by the County in 1993 and 1994 after initial FDIP approval in 1991. The landfill operator submitted a revised landscape plan for the Jacqueline Drive terminus on 8/30/1993 to account for a lack of water service previously requested from the City of Pittsburg and subsequently revised the plan in coordination with the County. See Plan B Landscaping Plan dated 12/28/1993.</p> <p>See Community Development Department letter from C. Zahn to T. Cox (KCLC) dated May 6, 1994 which authorized installation of Plan B landscaping.</p>
22.8	<p><b>Auxiliary Facilities Screening.</b> The landscaping plan shall provide for the screening of auxiliary areas, such as the administrative buildings, parking lots, maintenance facilities, and screening of facilities shall occur during the first year of development. Enhancement of Lawlor Creek shall occur during the first year, to aid in screening facilities from Bailey Road users.</p>	Completed	<p>Design approved by the County subsequent to initial FDIP approval in 1991. All required landscape screening of facilities has been installed and is regularly maintained. See Community Development Department letters from C. Zahn to T. Cox (KCLC) dated 7/30/1992 and 9/23/1992 which authorized installation of landscaping at the administration building, and scale house and maintenance building, respectively. Lawlor Creek corridor was improved in 1998 as part of the Lawlor Creek Restoration Plan.</p>
22.9	<p><b>Architectural Treatment.</b> Plans for buildings and other structures shall include architectural sections showing design and materials to be used. Buildings shall be designed to blend into the rural agricultural setting.</p>	Completed	<p>Architectural plans for buildings and other structures were included in the FDIP, Section 7.2. See Community Development Department letter dated 2/21/1992 from C. Zahn to B. Olney (KCLC) which authorized construction of auxiliary facilities as follows:</p> <ul style="list-style-type: none"> <li>-- Administration building: Building Permit CO-175997</li> <li>-- Maintenance building: Building Permit IN-175909</li> <li>-- Scale House: Building Permits MI-175450 &amp; MI-175970</li> </ul>

**EXHIBIT D - Compliance Status Table: Keller Canyon Landfill Land Use Permit 2020-89 Conditions of Approval**

Condition	Condition Description	Compliance Status	Comments
22.10	<p><b>Area of Operations.</b> Except during construction of modules and other major installations, the Landfill operator shall limit unvegetated working areas of the landfill, including the daily working face, to 25 acres for appearance and to control dust and erosion. The restriction shall not apply to grading for foundations, cover, site roads, berms and other construction, providing these are carried out expeditiously.</p>	In Compliance. On-Going	Limiting unvegetated working areas to the greatest extent possible is standard operating procedure.
22.11	<p><b>Interim Revegetation.</b> Interim revegetation shall be required on all areas that will be inactive for more than 90 days. Revegetation shall include native grasses, shrubs and trees to lend more variety and natural appearance to the finished landfill.</p>	In Compliance. On-Going	<p><b>UPDATE: Inactive areas typically generate ruderal vegetation during winter and spring as verified by site surveys. The working face is purposefully kept small (about 1 acre) at any given time to minimize the amount of area exposed.</b></p> <p>Interim revegetation of areas that will be inactive for more than 90 days is standard operating procedure. Also see Condition 20.9.</p>
22.12	<p><b>Water Tank Screening.</b> The Landfill developer shall provide landscaping to screen the facility's water tanks. Where possible, the landscaping shall be installed prior to the installation of the tank. Consideration shall be given to subsurface or partially buried tanks, and to painting the structures with earthtone colors.</p>	Completed	The water tank location was selected because it is not visible from off-site locations. Landscape screening of the water tank was not required due to natural topography and camouflage paint.
22.13	<p><b>Final Cover.</b> Final cover shall be contoured and landscaped to blend with existing topography.</p>	Not Yet Required	Final cover has not yet been implemented and will be performed in accordance with this LUP condition, and the approved Preliminary Closure and Post-Closure Maintenance Plan.
22.14	<p><b>Lighting.</b> The Landfill developer shall design and locate the lighting system to reduce glare and reduce impact to area residents. Focused directional security and operational lighting shall be installed. Operation lighting on the working face shall be turned off by 7:30 p.m. Security and entrance lighting shall be dimmed at 7:30 p.m.</p>	Completed	All on-site and security lighting has been installed and is directed generally downward to avoid glare. Operation of lighting systems is performed per this condition. Also see LUP Condition 9.1.
23.1	<p><b>Biotics Protection Objectives.</b></p> <p>a) The Landfill developer shall construct and operate the facility in such a manner that ensures, through protection and enhancement measures, that there is no net loss of significant habitat, wetland, woodland, or agricultural production.</p> <p>b) The Landfill developer shall provide at least twice the amount of mitigation wetland for significant wetland lost to the project (2-to-1 mitigation). A minimum of six acres of mitigation wetland shall be provided. Wetland loss shall be mitigated through the enhancement of stock ponds and sedimentation basins, or the creation of new wetlands.</p>	In Compliance. On-Going	<p>Four mitigation wetlands were created in 1992 in accordance with federal and state resource agencies. Total wetlands area of 8.57 acres, exceeded the 6.0-acre minimum for this Condition (USACOE permit minimum = 7.21 acres). A Biological Condition Compliance Review was conducted in 2003 which concluded that the 8.29 of mitigation wetlands in place at Keller did not warrant any wetland remediation (0.28 acres no longer met USACOE jurisdictional wetlands criteria). An additional 6.0 acres of Lawlor Corridor were enhanced through plantings of California native species and other riparian enhancements. These wetlands and enhanced areas continue to function as designed.</p> <p>See Community Development Department letter from C. Zahn to B. Olney (KCLC) dated 2/5/1992, which authorized construction of mitigation wetlands in the east Special Buffer Area in compliance with COA 23.1 and USACE Section 404 Nation-wide Permit No. 26. Streambed Alteration Agreement No. 1463-90 for wetlands construction was issued by the California Department of Fish and Game on 10/18/1991. The Final Wetland Mitigation and Monitoring Plan was substantiated by CDD on 10/23/1991.</p>

**EXHIBIT D - Compliance Status Table: Keller Canyon Landfill Land Use Permit 2020-89 Conditions of Approval**

Condition	Condition Description	Compliance Status	Comments
23.2	<p><b>Range Management Plan.</b> The Landfill operator shall design and develop a Range Management Plan in order to provide for continued grazing on portions of the site. The Special Buffer Area shall remain as Agricultural Preserve, and development rights shall be conveyed to the County. The buffer area and other site range-lands of the Primary Project Area not exempted for habitat protection and not in active landfill use shall be enhanced as grassland/oak woodland, and shall provide grazing for at least 270 head of cattle, approximately the same number of cattle which presently graze on the site. Stock watering ponds shall be enhanced through planting of trees and shrubs. Grazing shall be restricted for a 1 to 2 year period in order for grasses to get reestablished. It shall provide for adequate grazing range, and for native tree species such as oaks to be planted for animal protection and to replace trees removed during landfill construction, while controlling soil erosion. The plan shall be prepared in consultation with the Contra Costa County Resource Conservation District and the Agricultural Extension Service. It shall be coordinated with the Landscape Plan, the Habitat Preservation Plan, and the Erosion and Sediment Control Plan developed for the landfill facility. It shall be subject to the approval of the County Community Development Department and it shall be included in the Improvements and Development Plan.</p>	In Compliance. On-Going	<p><b>UPDATE: Grazing was continued as an important element of the Range Management Plan.</b></p> <p>Included in FDIP, Section 5.1 Range Management Plan and Drawing RM-1, approved by the Community Development Department. The buffer area is maintained within the guidelines of this condition for grazing, habitat preservation and fire protection.</p> <p>The Special Buffer Area continues to be under Williamson Act contract (Contra Costa County, 2008) and is zoned A-4, Agricultural Preserve.</p>
23.3	<p><b>Lawlor Creek Corridor Restoration Plan.</b> Enhancement of this riparian area shall replace habitat lost by the rerouting and covering of a portion of the unnamed drainageway within the waste placement area. This plan shall provide replacement for habitat lost to landfill construction. The Corridor Plan shall also provide screening of the landfill entrance and service facilities from Bailey Road. Livestock fencing shall be constructed around the perimeter of approximately 35 acres to exclude cattle from the riparian and oak woodland areas. Litter shall be removed from the creek and corridor, and fencing shall be established along Bailey Road to prevent unlawful disposal of trash. Riparian species of trees such as Willows, Fremont cottonwood, sycamore and other oak species, California Bay Laurel and shrubs shall be planted. The access road crossing of Lawlor Creek shall be designed and constructed in a manner that would be compatible with the aesthetics of the corridor and habitat enhancement. Installation of horizontal drainage pipes into hillsides may be provided to tap groundwater sources to improve creek flow conditions. A monitoring and maintenance program shall be established to insure wildlife habitat values are protected. Rock dams, overhangs, splash pools and erosion control structures shall be included in the corridor plan design. The detailed restoration plan shall be developed for Lawlor Creek in coordination with the County, the California Department of Fish and Game, U.S. Fish and Wildlife Service, local Audubon and California Native Plant Society representatives and other environmental organizations. A streambed alteration agreement shall be obtained if determined to be necessary by the CDF&amp;G. A wetland modification permit shall be obtained from the Army Corps of Engineers if necessary. Implementation of the Restoration Plan shall take place during the initial development phase of the Landfill.</p>	Completed	<p>Streambed Alteration Agreement No. 1461-90 for Lawlor Creek was issued by the California Department of Fish and Game on 10/18/1991. A Restoration and Enhancement Plan was prepared in accordance with requirements of the County, U.S. Army Corps of Engineers, and California Department of Fish and Game, and implemented in 1997 and 1998.</p> <p>General plans are included in FDIP, Section 5.2, Drawing LC-1 and Appendix C, approved by the Community Development Department.</p> <p>Final Section 404 Monitoring Report Submitted August 26, 1998. Also See LUP conditions 22.8 and 23.1.</p>
23.4	<p><b>Sandstone Outcrop Area.</b> Livestock fencing shall be constructed around the perimeter of the 72-acre sandstone area at the front of the Landfill to exclude cattle and preserve upland habitat area. Landfill personnel and construction operators shall be alerted regarding the protected area. Native trees such as Oak and California Buckeye shall be planted along the perimeter of this area. The adjoining equalization basin and toe berm shall be constructed to avoid damage to the protected area.</p>	Completed	<p>Sandstone outcroppings in this area have been protected by exclusionary livestock fencing. Siting and construction of landfill facilities in adjoining areas were implemented without damage to the sandstone outcrop area.</p>

**EXHIBIT D - Compliance Status Table: Keller Canyon Landfill Land Use Permit 2020-89 Conditions of Approval**

Condition	Condition Description	Compliance Status	Comments
23.5	<p><b>Weed Control Program.</b> The landfill operator shall submit a weed control program to control introduced weedy species on the Landfill property as part of the Range Management Plan. The program is subject to approval by the County Conservation and Development Department. The weed control program shall include a list of noxious weeds, periodic monitoring of these species, and a weed control and removal program.</p>	In Compliance. On-Going	Weed control is performed in accordance with this condition, the Range Management Plan, and County Weed Abatement.
23.6	<p><b>Phased Construction.</b> The Landfill operator shall construct and operate the Landfill in phases in order to reduce the acute impact to vegetation and wildlife habitat. Mature trees should be removed only as needed, not more than one year in advance of module development. Black walnut and other heritage tree cuttings shall be taken with the direction of a research organization such as the University of California's botanical garden.</p>	In Compliance. On-Going	Phased construction has been implemented since the landfill opening in 1992. No Black Walnut or heritage trees or high quality wildlife habitat exist within the approved area of disturbance for landfill facilities or operations.
23.7	<p><b>Vegetation Protection.</b> The Landfill developer shall employ dust suppression measures to prevent damage from dust loading on vegetation. Periodic watering of vegetation adjacent to the fill working area shall be developed as part of the Range Management Plan.</p>	In Compliance. On-Going	Dust suppression measures are implemented in accordance with this LUP condition, Condition 17k(d) of the SWFP, and requirements of Condition #17309 in the Major Facility Review permit issued by BAAQMD. Also see Condition 20.5.
23.8	<p><b>Wildlife Exclusion and Vector Control.</b> The Landfill operator shall construct fences around the working area of the site, limit the size of the working face, and cover refuse at least daily in order to exclude wildlife and control vectors at the working area of the site.</p>	In Compliance. On-Going	Wildlife exclusion and vector control are implemented per the requirements of this condition and the SWFP regulating landfill operation. Fences in the working area for wildlife exclusion have not proven necessary as determined by the LEA. The working face size is limited to less than 3 acres by Condition 17.17 of this LUP, and 1 acre by Condition 17h in the SWFP.
23.9	<p><b>Supplemental Wildlife Surveys.</b> The Landfill developer shall conduct additional surveys to establish the presence or indicate the absence of the following species at the landfill site.</p> <p>a) San Joaquin Pocket Mouse. The survey shall be conducted according to USFWS recommendations. If found, the developer shall follow USFWS guidelines regarding appropriate mitigation procedures.</p> <p>b) The California Tiger Salamander and the Alameda Whipsnake. The salamander study shall take place during the rainy season. If salamanders are found to exist in the unnamed creek, they shall be trapped and released to the Lawlor Creek area. If the Alameda Whipsnake is encountered, then facilities such as the equalization basin, and the access road shall be relocated further from the outcrop area. The outcrop reserve shall be expanded to include the easternmost outcrops. Consideration shall be taken in siting facilities and any activities north of access road. Lighting shall be shielded and shall illuminate only paved areas in this vicinity.</p>	Completed. Updated As Needed	<p>Supplemental wildlife surveys were conducted in 2003. No special status wildlife species were observed in the primary project area of the landfill during site visits. Based on existing habitat conditions, there is a moderate to high potential of occurrence for three special status wildlife species to occur on or adjacent to the primary project area: 1) San Joaquin pocket mouse, 2) California horned lark, and 3) loggerhead shrike. Two additional species, the California tiger salamander and the California red-legged frog, occur in adjacent areas and could disperse through the project area. Habitat assessments for these species were conducted in accordance with state and federal guidelines. The habitat assessments concluded that surveys were not warranted based on the probability the species may occur in the primary project area of the landfill, as follows: California red-legged frog = low probability, California tiger salamander = low probability,</p> <p>Earlier supplemental survey data submitted to the U.S. Fish and Wildlife Service were substantiated by CDD on 10/15/1991. See Community Development Department Memo, V. Conklin to C. Zahn, dated 10/15/1991, and as updated through 10/25/1991.</p>

**EXHIBIT D - Compliance Status Table: Keller Canyon Landfill Land Use Permit 2020-89 Conditions of Approval**

Condition	Condition Description	Compliance Status	Comments
24.1	<b>Bird and Vector Control Objective.</b> The Landfill operator shall manage the facility in such a manner that prevents and controls the attraction and/or generation of birds and vectors at the site.	Objective	This is solely an Objective. See Conditions 24.2 - 24.7. Compliance with these conditions of approval in LUP Section 24. Bird and Vector Control prevents and controls attraction and/or generation of birds and vectors at the landfill operations area.
24.2	<b>Soil Cover Frequency.</b> See Condition 20.3.	Cross-Reference	This condition solely cross-references another LUP condition. See Condition 20.3.
24.3	<b>Working Face.</b> See Condition 17.17	Cross-Reference	This condition solely cross-references another LUP condition. See Condition 17.17.
24.4	<b>Bird Control.</b> If birds become a problem at the Landfill in the judgement of Contra Costa Environmental Health, the Landfill operator shall institute a contingency bird control program. Such a program may consist of monofilament or wire lines suspended in the air at appropriate intervals over and around the active disposal area. The Landfill operator shall retain a biologist during the initial period of operation to (1) assess the effectiveness of the monofilament line for bird control and (2) assess the effect of the line on avian predator species. If necessary, additional corrective measures shall be taken at that time. Such measures may include a reduction in the size of the working face of the landfill, the use of nets over the working face, or the use of a habitat manipulation and modification program.	In Compliance. On-Going	Implementation of LUP COA 24.4 and 24.5 is routinely coordinated with the SWFP Section 17k(f). The Bird Control Plan for Keller Canyon Landfill was updated on January 14, 2014. The plan includes elements on bird species identification, bird control methods, and specific bird control measures. The control program involves dispersal in conjunction with whistlers, crackershells, and distress calls played over a loudspeaker attached to a vehicle. Monthly on-site inspections by the LEA have not indicated problems with control of birds and vectors.
24.5	<b>Rodent Control.</b> If waste compaction does not eliminate live rodents from the Landfill footprint, or if rodents (other than small numbers of field mice, etc.) occupy facility landscaping or agricultural areas, the operator shall work with the local enforcement agency to identify the reasons for the presence of rodents and make appropriate changes in operational procedures. If an eradication program is necessary, the use of alternative rodent control programs such as sustained live trapping using nonpoisonous baits, and natural biological control shall be considered. Anti-coagulants shall be administered by a pest management professional in a manner which minimizes exposure to avian predators. Class 1 pesticides shall not be used.	In Compliance. On-Going	See 24.4 above.
24.6	<b>Mosquito Control.</b> The Landfill operator shall grade areas within the Landfill property to prevent ponding of water which could harbor mosquitos (except for sedimentation ponds and riparian habitat areas). Sedimentation ponds shall be stocked with mosquito fish unless otherwise specified by the Mosquito & Vector Control District. If a mosquito problem persists, Contra Costa Environmental Health may require the preparation and implementation of additional mosquito control measures, such as spraying of non-toxic larval suppressant.	In Compliance. On-Going	See 24.4 above. The landfill operator works closely with the County Mosquito Abatement District to ensure approved controls and methods are used to control mosquitos. If required, stocking of sedimentation ponds with mosquito fish would be implemented as directed by the County Mosquito Abatement District. Typically there is insufficient standing water in the sedimentation basin to support mosquito fish.
24.7	<b>Fly Control.</b> The Landfill operator shall limit the size of the working face and shall cover refuse daily in order to prevent fly proliferation. If an eradication program is necessary, the use of a pest-control specialist shall be considered and a plan implemented pursuant to approval by Contra Costa Environmental Health.	In Compliance. On-Going	Fly control is achieved by limiting the size of the working face per LUP Condition 17.17 and Condition 17h of the SWFP. Cover practices and materials are in accordance with requirements of both permits. Also see Condition 24.4.

**EXHIBIT D - Compliance Status Table: Keller Canyon Landfill Land Use Permit 2020-89 Conditions of Approval**

Condition	Condition Description	Compliance Status	Comments
25.1	<p><b>Litter Control Objective.</b> The Landfill operator shall manage the facility in a manner which confines litter to the working face of the Landfill, which prevents litter from accumulating another parts of the site, and which prevents litter from being blown off the site.</p>	Objective	<p>This is solely an Objective. See Conditions 25.2 - 25.11.</p> <p><b>UPDATE: In 2015 substantial improvements were made to the facility's on-site litter control system. See conditions 25.5 and 25.6 below. No uncontrolled litter incidents occurred in 2015.</b></p> <p>The site is in compliance. Litter control is conducted during all hours of operation as specified in Section 25 of this LUP and condition 17k(e) of the SWFP.</p>
25.2	<p><b>Load Covering.</b> The Landfill operator shall implement a program requiring landfill users (customers) to securely containerize their load to avoid littering and exclude uncovered loads from arriving at the Landfill consistent with the requirements of Section 418-2.008 of the County Code. The program shall be subject to the approval of the County Department of Conservation and Development and Contra Costa Environmental Health. See also Condition 7.2.</p>	In Compliance. On-Going	<p>See Conditions 7.1 and 7.2 for load covering requirements.</p>
25.3	<p><b>Load Cover Enforcement.</b> If routine enforcement of load cover requirements is not effective, the Landfill operator shall offer to contract with the Sheriff's Department to enforce regulations requiring the covering of trucks and trailers.</p>	Not Yet Required	<p><b>UPDATE: Republic Services removed the "How's My Driving?" stickers from their trucks and replaced them with "Together for Safer Roads" stickers. Incidents of litter bounce out from Republic trucks can still be recorded using the truck number which identifies every truck, and using the local phone number printed on all trucks. Republic Services is a member of Together for Safer Roads, an organization made up of private sector companies dedicated to improving traffic safety on the nation's roads. Republic is implementing a program of Best Practices for its fleet of vehicles related to road safety management, safer roads and mobility, safer vehicles, and safer road users. Republic trucks and trailers are numbered. Complainants must call Keller directly to report concerns.</b></p> <p>Every incoming load is inspected to ensure all waste-hauling vehicles are covered. Waste loads are screened for excessive littering and inadequate covering. All transfer trucks are required to have tarps covering their loads. In addition, all transfer trucks owned by the landfill operator have large easily visible truck numbers that allows citizens to contact the operator if litter is observed falling from transfer trucks. The Landfill owner/operator has had no cause to request load cover enforcement from the County Sheriff's Department.</p>
25.4	<p><b>Contingency Litter Control.</b> Under windy conditions, the Landfill operator shall cover the refuse with County approved cover materials as often as necessary to control blowing litter. Other options shall be considered as necessary, including the alignment of unloading areas away from the prevailing wind direction, increasing the number of compactors, decreasing the active face size, and reducing the number of vehicles tipping at one time. The Contingency Litter Control measures shall be contained in the Litter Control and Prevention Program that is subject to review and approval of the Department of Conservation and Development and Contra Costa Environmental Health. Contra Costa Environmental Health shall have the authority to enforce this requirement. See Section 20.8.</p>	In Compliance. On-Going	<p><b>UPDATE: Contingency litter control has not been necessary since the last Permit Review.</b></p> <p>Portable litter fences are provided as necessary around the unloading and receiving areas to prevent litter from migrating off-site. A permanent litter fence has been constructed at the east edge of the landfill operations area. In the event that litter is generated by extremely high winds, the Landfill owner/operator deploys emergency crews to collect on and off-site litter blown beyond the normal containment areas.</p> <p>Litter incidents are recorded by DCD and also in the Log of Special Occurrences maintained by KCL. Also see Condition 20.2. The Department of Conservation and Development is not aware of any complaints related to litter that have not been addressed in a timely manner by the landfill operator.</p>

**EXHIBIT D - Compliance Status Table: Keller Canyon Landfill Land Use Permit 2020-89 Conditions of Approval**

Condition	Condition Description	Compliance Status	Comments
25.5	<p><b>Portable Litter Fences.</b> The Landfill operator shall install portable fencing near the working face of the Landfill to intercept windblown debris.</p>	In Compliance. On-Going	<p><b>UPDATE: In 2015, additional movable "bull fences" were installed for use in proximity to the Phase 3B1 working face.</b></p> <p>Portable litter fences were initially approved as submitted in the Solid Waste Facility Permit, subject to continued inspection by the County HSD (see memo from C. Nicholson, HSD to C. Zahn, CDD dated 3/10/1992).</p> <p>Portable litter fences are provided as necessary around the unloading and receiving areas to prevent litter from migrating off-site per this LUP condition and condition 17k(e) of the SWFP.</p>
25.6	<p><b>Permanent Litter Fence.</b> The Landfill operator shall install a permanent fence of wire around the current fill area of the Landfill. The location shall be subject to the approval of Contra Costa Environmental Health.</p>	Completed. On-Going	<p><b>UPDATE: In 2015, the existing 20-foot-tall permanent litter fence at the top of the main haul road was extended approximately 1,500 feet to the west; approximately 1,100 feet of new 20-foot-tall permanent litter fence was also installed upslope and south of the main haul road adjacent to Phase 3B1. KCL regularly removes litter from these permanent litter fences. It also maintains a litter pick up labor force that can be deployed immediately in the event of an on or off-site litter incident.</b></p> <p>The permanent litter fence was initially approved as submitted in the SWFP, subject to continued inspection by the County HSD (see memo from C. Nicholson, HSD to C. Zahn, CDD dated 3/10/1992).</p> <p>The permanent litter fence was installed prior to commencement of landfill operations in 1992.</p>
25.7	<p><b>On-Site Litter Policing.</b> The Landfill operator shall remove litter from the litter fences and planting screens at least once each day. On-site roads, including 500 feet of Bailey Road south of the site entrance, shall be policed at least daily. Contra Costa Environmental Health may require more frequent policing to control the accumulation of litter.</p>	In Compliance. On-Going	<p>Keller Canyon Landfill has an extensive litter control program in place. The landfill operator enforces the covered load program at the scale house by reminding any untarped customers (which are rare) of the requirement. Daily on-site litter removal is performed in accordance with this LUP condition, the Litter Management Plan, and the SWFP Condition 17k(e). Monthly inspections by the LEA have indicated an acceptable level of litter control. Extensive onsite controls are in place to ensure litter is controlled within the site boundaries.</p>



**EXHIBIT D - Compliance Status Table: Keller Canyon Landfill Land Use Permit 2020-89 Conditions of Approval**

Condition	Condition Description	Compliance Status	Comments
25.8	<p><b>Off-Site Litter Policing.</b> The Landfill operator shall provide weekly (or more frequent) litter clean-up along Bailey Road from Highway 4 to at least 500 feet south of the site entrance. Based on experience, the County Department of Conservation and Development or Contra Costa Environmental Health may modify frequency of clean-up and/or area of coverage. If wind-blown litter from the landfill reaches other properties, the Director of Environmental Health or the Director of Conservation and Development may require the Landfill operator to remove the litter and the Director(s) may require the operator to institute additional measures to prevent recurrence of the problem.</p>	In Compliance. On-Going	<p><b>UPDATE:</b> In response to County and City of Pittsburg concerns about off-site litter, KCL continued with a voluntary weekly litter pick up program for the vacant parcels on the east side of Bailey Road, between West Leland Road and the Highway 4 ramps as described below. A log is maintained at the landfill office detailing dates of pick up for the year 2015 to-date. A log of off-site litter policing is also maintained for the residential areas north of the landfill in residential areas in the vicinity of San Remo Way, Jacqueline Drive, and Santa Maria Way. Where applicable, before and after photos are taken of litter incidents and subsequent clean up. KCL maintains a litter pick up labor force that can be deployed immediately in the event of an on or off-site litter incident.</p> <p>Off-site litter removal is performed from West Leland Road to at least 500 feet south of the landfill entrance in accordance with this LUP condition and the facility Litter Control and Prevention Plan. . In addition, Keller Canyon Landfill's litter control program includes voluntary pick up of litter in areas between Highway 4 and W. Leland Road. Landfill personnel regularly pick up litter in the vacant lot by the bus stop across from the shopping center on Bailey Road. In addition, the landfill operator participates in the Adopt-a-Highway program for the area from the San Marco exit to Bailey Road, including the off-ramp at Bailey Road. This program was previously suspended at the direction of CalTrans during Hwy 4 construction, but was recently re-instated at the request of Keller Canyon Landfill. The landfill operator also enforces the covered load program at the scale house by reminding customers with untarped loads (which are rare) of the requirement.</p>
25.9	<p><b>Littering Signs.</b> The Landfill operator shall post signs, as determined necessary by the County Public Works Department, along access roads to the Landfill noting littering and illegal dumping laws. The Landfill operator shall post signs at the Landfill entrance noting the hours when the Landfill is open. The operator should periodically publish these laws and operating hours in mailings to Landfill clientele.</p>	Not Yet Required	<p>A sign specifying landfill operating hours is posted at the site entrance. Off-site signage was deemed unnecessary by the County Public Works Department (PWD) . (See memo from J. Causey, PWD to C. Zahn, CDD dated 2/26/1992.) The County staffs and maintains a countywide illegal dumping hotline and the phone number is: 1-800-NO-DUMPING or (1-800-663-8674)</p> <p>With <b>nearly 24</b> years of continuous operation in which public self-haul is prohibited, landfill clientele are familiar with facility operating hours as opposed to potential conflicts that may occur from self-haul customers who arrive at the facility after hours. There have been no instances of illegal dumping for example, resulting from a customer who arrived at the facility after hours.</p>
25.10	<p><b>Clean-Up Bond.</b> The Landfill developer shall deposit a surety bond for \$10,000 payable to the County to use for clean-up in the event of emergency or disputed littering or spills.</p>	In Compliance. On-Going	<p>The initial Performance Bond (# 571-10-31) in the amount of \$10,000 went into effect on 5/7/1992. It was issued by Safeco Insurance as a surety for Contra Costa County in the event it was needed to clean-up litter or spills not remedied by the Operator. The initial Bond listed BFI which was the parent company that owned the landfill at the time. Since that time the parent company has changed more than once and the Bond had also been renewed. The landfill operator secured a new bond in the name of Republic Services, the current parent company which is on file with County DCD.</p>
25.11	<p><b>Public access.</b> Public access to the landfill shall be prohibited unless such access is provided for special events, such as tours, open house functions or wetland field trips for local schools.</p>	In Compliance. On-Going	<p>Signage prohibiting public access to the landfill is posted at the landfill entrance and enforced on-site.</p>

**EXHIBIT D - Compliance Status Table: Keller Canyon Landfill Land Use Permit 2020-89 Conditions of Approval**

Condition	Condition Description	Compliance Status	Comments
26.1	<p><b>Safety Objective.</b> The Landfill operator shall manage the facility in a manner which does not impair the safety of persons living in its vicinity, Landfill users, or Landfill employees.</p>	Objective	<p>This is solely an Objective. See Conditions 26.2 - 26.11.</p> <p><b>UPDATE: In 2015 through July 31, 2016, there was no lost time due to injuries or accidents. KCL maintains a very active safety program and conducts monthly safety meetings.</b></p> <p>Implementation of conditions of approval in this LUP Section 26. Public Safety has maintained a high degree of safety for landfill users, employees, and the surrounding area.</p>
26.2	<p><b>Emergency Plan.</b> The Landfill operator shall prepare an emergency plan specified by the Solid Waste Facilities Permit and approved by Contra Costa Environmental Health. The emergency plan shall include the following:</p> <ul style="list-style-type: none"> <li>(a) A fire and explosion component.</li> <li>(b) A seismic component.</li> <li>(c) A hazardous waste spills and contamination containment component.</li> <li>(d) An evacuation component.</li> </ul>	Completed. On-Going	<p>The Emergency Plan was originally approved by County HSD as submitted in the RDSI in 1992 (See memo from C. Nicholson, HSD to C. Zahn, CDD dated 3/10/1992). The current Emergency Plan is contained in the updated RDSI which was approved in conjunction with the Solid Waste Facility Permit by HSD and CalRecycle.</p>
26.3	<p><b>Employee Safety Equipment.</b> The Landfill operator shall provide or require employees to provide safety equipment, such as safety glasses, hard hats, safety shoes, gloves, coveralls, and noise reducers as required by state and federal safety agencies and Contra Costa Environmental Health.</p>	In Compliance. On-Going	<p>Safety equipment is provided to landfill personnel as necessary in compliance with 27 CCR, 21600(b)(5)(F). Equipment includes: boots, hard hats, reflective vests, ear and eye protection, filtration masks and self-contained breathing apparatuses. All personal protective equipment (PPE) used by KCL employees in the course of their work must be used and maintained in a sanitary and reliable condition, whenever it is required, based on hazard assessments of district job/tasks. A hazard assessment using the PPE matrix included in the Personal Protective Equipment Program included in Appendix E must be performed for each distinct job/task to determine if hazards are present which require use of PPE. In Fire extinguishers are located in onsite buildings, operating equipment and maintenance and support vehicles.</p>
26.4	<p><b>Employee Training.</b> The Landfill operator shall develop and implement training and subsequent refresher training programs covering accident prevention, safety, emergencies and contingencies ("bad-day" scenarios), gas detection, identification of hazardous materials and ground fissures, first aid, and instruction in the use of equipment. The programs shall be subject to the approval of Contra Costa Environmental Health.</p>	In Compliance. On-Going	<p><b>UPDATE: Training records are kept for each employee and maintained in personnel files. Additionally, all KCL employees participate in a company-wide, monthly safety incentive program. This program provides financial rewards to employee groups for demonstrated safe work habits.</b></p> <p>The training program was originally approved by County HSD as submitted in the RDSI in 1992 (see memo from C. Nicholson, HSD to C. Zahn, CDD dated 3/10/1992). All employee safety training is performed in accordance with this LUP condition and State requirements. Training for operations personnel is provided in health and safety, hazardous waste identification, handling and storage procedures, environmental control systems management and proper waste handling and disposal procedures. Training provides site personnel with a thorough understanding of operator responsibilities to ensure that landfill operations are conducted under safe working conditions to minimize potential public health and safety problems, and to maintain a high degree of compliance with all applicable solid waste handling and disposal regulations.</p>

**EXHIBIT D - Compliance Status Table: Keller Canyon Landfill Land Use Permit 2020-89 Conditions of Approval**

Condition	Condition Description	Compliance Status	Comments
26.5	<b>First Aid Equipment.</b> The Landfill operator shall provide and maintain supplies located in easily accessible areas. The first aid supplies shall be consistent with the Occupational Safety and Health Administration requirements and subject to the approval of Contra Costa Environmental Health.	In Compliance. On-Going	All employee first aid equipment is provided in accordance with this LUP condition, and State and federal requirements, and subject to monthly inspections by the LEA.
26.6	<b>Emergency Communications.</b> The Landfill operator shall provide radio phones or telephones for employee use to call for medical and other emergency assistance. Phone numbers to use for outside emergency assistance shall be clearly posted on the Landfill and in other work areas. The communications system shall be subject to the approval of Contra Costa Environmental Health.	In Compliance. On-Going	The emergency communications system was originally approved by County HSD as submitted in the 1992 RDSI (see memo from C. Nicholson, HSD to C. Zahn, CDD dated 3/10/1992). All emergency communications equipment and phone numbers are in accordance with this LUP condition and State requirements, and subject to monthly inspections by the LEA. In accordance with 27 CCR, Section 20615, the LEA, local health agency have been notified in writing of the names, address, and telephone number of the operator. A list of names of the site personnel for KCL to contact in the event of an emergency, along with the emergency procedures, are posted in the site office and operations trailer.
26.7	<b>Emergency Eye Baths and Showers.</b> The Landfill operator shall provide facilities for emergency eye baths and emergency showers. The facilities shall be subject to the approval of Contra Costa Environmental Health.	In Compliance. On-Going	All emergency eye baths and showers are in accordance with this LUP condition and State requirements, and subject to monthly inspections by the LEA.
26.8	<b>Equipment Maintenance.</b> The Landfill operator shall prepare and implement an equipment maintenance program which shall be approved by Contra Costa Environmental Health prior to the commencement of operations. The program shall address transfer vehicles and other refuse-conveying vehicles stored on the site as well as the station's refuse-moving vehicles and mechanical equipment. Vehicles and equipment shall be regularly cleaned to reduce the risk of fires.	In Compliance. On-Going	The equipment maintenance program was originally approved by County HSD as submitted in the 1992 RDSI (see memo from C. Nicholson, HSD to C. Zahn, CDD dated 3/10/1992). Equipment maintenance is performed according to manufacturer specifications and at required intervals. Maintenance records are maintained by the operator and available for review by County agencies.  See Health Services Department Memo from C. Nicholson to C. Zahn (CDD) dated 3/10/1992.
26.9	<b>Gas Migration Monitoring.</b> The Landfill operator shall prepare and implement a gas migration monitoring program to detect underground gas migration. Landfill buildings and paved areas within 1,000 feet of the Landfill disposal area shall be monitored unless otherwise specified in state regulations. The monitoring program shall be approved by Contra Costa Environmental Health.	Completed. On-Going	The gas migration monitoring program was originally approved by County HSD as submitted in the 1992 RDSI, subject to continued inspection (see memo from C. Nicholson, HSD to C. Zahn, CDD dated 3/10/1992). Landfill Gas Migration Monitoring is performed per this condition and requirements of permits with the BAAQMD
26.10	<b>Refuse Cover.</b> See Condition 20.3.	Cross-Reference	This condition solely cross-references another LUP condition. See Condition 20.3.
26.11	<b>Load Inspection.</b> See Condition 7.1.	Cross-Reference	This condition solely cross-references another LUP condition. See Condition 7.1.

**EXHIBIT D - Compliance Status Table: Keller Canyon Landfill Land Use Permit 2020-89 Conditions of Approval**

Condition	Condition Description	Compliance Status	Comments
27.1	<b>Security Objective.</b> The Landfill operator shall manage the facility in a manner which prevents unauthorized persons from having access to the working areas of the Landfill both during and after operating hours.	Objective	This is solely an Objective. See Conditions 27.2 - 27.4.  <b>UPDATE: There were no security breaches of the site or facilities in 2015 or 2016 to-date.</b>  Site security at the site includes: a locked entrance gate, fencing along the entire property boundary and the manned fee booth/scale area. Access to the site is monitored by the Fee Station Attendants at the scale house when the facility is open for business. A fence around the entire facility controls unauthorized access to the site. The LFGTE facility and flare station are fenced off and locked during non-business hours while the sedimentation basin is also fenced off along the edge of the perimeter or access road. At all other times, the entrance gate is securely locked. Security lighting is provided at the entrance gate, the administrative building, the scale house area, the maintenance facilities, and the utilities areas. KCL can provide additional site security measures, as deemed necessary.
27.2	<b>Security Fencing.</b> The Landfill developer shall install a security fence around the perimeter of the site with lockable gated entrances and exits. The fence shall be located to minimize its visual impacts. It shall be included in the Development and Improvements Plan.	Completed	The Security Fencing plan is included in FDIP Section 10.10. Approved by the Riverview Fire Protection District on 10/22/1991. County HSD deferred to the Fire District's approval (see memo from C. Nicholson, HSD to C. Zahn, CDD, dated 10/24/1991. See memo from V. Conklin, CDD to C. Zahn, CDD dated 10/15/1991, and as updated through 10/25/1991.  Security fencing was installed prior to the landfill opening. The initial portion of fencing was authorized in a Community Development Department letter from C. Zahn to B. Olney (KCLC) dated 2/6/1992; installation of the remainder of perimeter fencing was authorized by CDD in a letter from C. Zahn to B. Olney, KCLC dated 7/24/1992. Fencing is maintained or repaired as the need arises.
27.3	<b>Security Staffing.</b> The Landfill operator shall staff the Landfill 24 hours per day. Private security services may be retained when the site is not open to patrol and/or aid with investigating after hours odor complaints (see Condition 20.2) as needed.	In Compliance. On-Going	Private security services patrol the site when the landfill is not open, from landfill closure until 6:00 A.M. and all day on Sunday. The level of security is managed to ensure landfill assets are protected. On-site patrols include all landfill buildings, facilities such as the scalehouse, flare system, water tank, and leachate tanks, and major equipment. Security breaches have been very rare at the site. No buildings or facilities have experienced forced entry or burglaries. The last incident involved vandalized windows on a piece of earthmoving equipment in 2008.
27.4	<b>Security Lighting.</b> The Landfill developer shall install and operate adequate lights at the entrance area to the Landfill. The lighting shall be provided in a manner which minimizes glare to nearby residents and road users. The security lighting shall be covered in the Development and Improvements Plan.	In Compliance. On-Going	The Security lighting plan is included in the FDIP, Section 10.11. Lighting was installed and is maintained per the requirements of this condition and the FDIP. Security lighting is operated in compliance with LUP Condition 9.1.
28.1	<b>Cultural Resource Preservation Objective.</b> The Landfill developer shall construct the facility in such a manner that preserves important archaeological or historic sites.	Objective	This is solely an Objective. See Conditions 28.2 - 28.3.  Implementation of conditions in LUP Section 28. Cultural Resources has preserved known cultural resources.
28.2	<b>Employee Access.</b> Employee access to the buffer area, the Lawlor Creek area, or the sandstone outcrop area shall be limited to duties associated with landfill maintenance. Artifact collection or vandalism in these areas shall be strictly prohibited.	In Compliance. On-Going	There are no regular landfill disposal operations in the Special Buffer Area or Lawlor Creek corridor. Public access is prohibited. Employee access to these areas is limited.

**EXHIBIT D - Compliance Status Table: Keller Canyon Landfill Land Use Permit 2020-89 Conditions of Approval**

Condition	Condition Description	Compliance Status	Comments
28.3	<p><b>Archaeology.</b> The Landfill operator shall cease work in the immediate area if buried human remains or archaeological features (e.g., petroglyphs) are uncovered during construction or operation. Work in the immediate area shall cease until a qualified archaeologist is consulted and approves resumption of work. Should human remains which may be of Native American origin be encountered during the project, the County Coroner's Office shall be contracted pursuant to the procedures set forth in the Health and Safety Code. The County Conservation and Development Department shall also be notified.</p>	In Compliance. On-Going	To-date, no buried human remains or archaeological resources have been discovered during site development or landfill operations.
29.1	<p><b>Traffic Objective.</b> The Landfill operator shall manage the facility in such a manner that provides safe, efficient transport of solid waste, while minimizing impacts to County residents.</p>	Objective	<p>This is solely an Objective. See Conditions 29.2 - 29.10.</p> <p>Implementation of conditions of approval in LUP Section 29. Transportation and Circulation is meeting the objectives of safety, efficient transport, and minimizing traffic impacts to area residents. The Traffic and Circulation Plan is included in the FDIP, Sections 11.1 through 11.7.</p>
29.2	<p><b>Access Route.</b> Access to the landfill facility shall be via State Highway 4, and Bailey Road unless alternate routes are approved by the County Department of Conservation and Development on an interim basis. No waste-hauling traffic shall be allowed entrance to the landfill from Bailey Road south of the site. The Landfill operator shall specify use of the prescribed route in all user contracts and shall notify non-contract users of the requirement. At the request of the Board of Supervisors, the Landfill Operator shall reimburse the County for the cost of enforcement of this Condition on the access route. The Board of Supervisors may also request the Landfill operator to reimburse the City of Concord for an access control police inspection stop on Bailey Road should it become necessary to enforce this access route condition.</p>	In Compliance. On-Going	The vehicle access route to/from the landfill is strictly enforced by the Landfill operator. The prescribed route is specified in all user contracts. Non-contract users are informed of the prescribed access route. No additional enforcement from City of Pittsburg or City of Concord law enforcement has been required.
29.3	<p><b>Landfill Access Road.</b> The Landfill developer shall install a paved, two-lane access road between Bailey Road and the edge of the current working lift of the landfill. A facility parking lot, a bridge across Lawlor Creek, a 12-foot turnaround lane, and parking/turn-off lanes shall be provided. the traffic lanes shall be built to a suitable Traffic Index (between 10.0 and 10.5). The roadway shall be constructed of all-weather driving surfaces of not less than 20 feet of unobstructed width, and not less than 13'-6" of vertical clearance, to all landfill areas within the site. The road shall not exceed 20% grade, shall have a minimum centerline turning radius of 30 feet, and must be capable of supporting the imposed loads of fire apparatus (20 tons). The access road shall be operational when the landfill opens. All costs shall be borne by the Landfill developer. The design and specifications of the roadway shall be approved by the County Public Works and Conservation and Development Department in consultation with the applicable Fire Protection District.</p>	Completed	<p>Landfill Access Road design information is included in the FDIP, Section 11.1, Drawings 8-13. Approval for completion of on-site roads was issued by CDD in a letter from H. Bragdon to B. Olney, KCLC dated 12/13/1991. A memo from C. Nicholson, HSD to C. Zahn, CDD dated 12/12/1991 concurred that all paved roads met design specifications and requirements Title 14 CCR. Authorization to construct Bailey Road improvements; and landfill entrance and intersection design was issued by CDD in a letter from C. Zahn to B. Olney, KCLC dated 12/20/1991. Final Construction Quality Assurance (CQA) for Phase 1A completed July 29, 1992. The landfill access road was designed and constructed in accordance with standards of the County Department of Public Works.</p>

**EXHIBIT D - Compliance Status Table: Keller Canyon Landfill Land Use Permit 2020-89 Conditions of Approval**

Condition	Condition Description	Compliance Status	Comments
29.4	<p><b>Landfill Entrance.</b> The Landfill developer shall construct the Bailey Road entrance to the site in a manner that provides safe access into the landfill. This improvement shall include the following for proper sight distance and intersection design: a separate left turn lane at least 150 feet in length and an acceleration lane, at least 1200 feet in length, leading north on Bailey Road, away from the site. The landfill developer shall also become responsible for a traffic signal at a later date, if warranted. The County Public Works Department shall approve the design of the entrance and estimate its cost. All costs shall be borne by the Landfill developer.</p>	Completed	Landfill Entrance design is included in FDIP, Section 11.2. The landfill entrance was designed and constructed in accordance with standards of the County Department of Public Works.
29.5	<p><b>Bailey Road, Pittsburg city limits to the Landfill Entrance.</b> The Landfill developer shall reconstruct the sections of Bailey Road between the city limits and the landfill entrance. The reconstructed roadway shall provide the sight distance, and roadway geometrics (including shoulder widening) specified by the County Public Works Department for truck use. This shall include two twelve-foot lanes with eight-foot shoulders. These improvements shall be in place prior to commencement of landfill operations. The Landfill developer shall upgrade the pavement capacity to reflect a 20-year life (an estimated Traffic Index of 10.0 - 10.5) along Bailey Road between the Pittsburg city limits and the landfill entrance. The County Public Works Department shall approve the design of the roadway and pavement reconstruction and estimate its cost. All costs shall be borne by the Landfill developer.</p>	Completed	<p>Design plans for reconstruction of Bailey Road is included in FDIP, Section 11.3, Drawings 4 through 7. The section of Bailey Road as defined in this condition was designed and constructed in accordance with standards of the County Public Works Department.</p> <p>On 10/20/1992 the Board of Supervisors authorized a Joint Exercise of Powers Agreement (JEPA) between the County and the City of Pittsburg for the purpose of constructing certain road improvements to Bailey Road within the City's jurisdictional boundaries from just south of West Leland Road to just north of Maylard Street. The JEPA became effective on 3/18/1993. The County Public Works Department had oversight over the project designs, construction, and conducted final inspections in consultation with the City.</p> <p>A Memorandum of Understanding (MOU) was also established on 10/1/1992 between the County and the Keller Canyon Landfill Company. By order of the Board of Supervisors dated 10/20/1992, the County approved the Keller Canyon Landfill Company and the disbursement of monies from the Transportation System Impact Fee account in an amount not to exceed \$300,000.</p>
29.6	<p><b>Bailey Road Pavement Study.</b> The Landfill developer shall conduct a study of the Bailey Road roadway from the Pittsburg city limits to the Highway 4 interchange to determine the improvements necessary to re-construct the right hand (outside) traffic lanes of the road to a 20-year pavement standard to be an estimated Traffic Index of 10.0 to 10.5. The County Public Works Department, in consultation with the City of Pittsburg, shall estimate the costs of the improvements, estimate the longevity of the existing roadway under increased traffic conditions, and determine a per-ton refuse disposal surcharge adequate to fund the improvements when reconstruction is necessary. The Landfill operator shall impose the surcharge and pay it quarterly into a segregated account established by the County. The design of the improvements, their costs, the surcharge and its disbursement shall be approved by the Board of Supervisors.</p>	Completed	The initial pavement study is included in the FDIP, Section 11.4 and Appendix F. A subsequent comprehensive pavement study was completed by the County Department of Public Works in 2009 prior to the rehabilitation of Bailey Road between the Highway 4 interchange and West Leland Road.
29.7	<p><b>Road Maintenance.</b> Subsequent to the funding of the above traffic lane upgrading improvements, the landfill operator shall impose a surcharge for the maintenance of Bailey Road between the Highway 4 interchange and the Landfill intersection. The surcharge shall be estimated by the County Public Works Department in consultation with the City of Pittsburg and shall be based on the landfill's proportionate share of traffic on the road corridor adjusted for vehicle weight and number of axles. The fees shall be paid quarterly into a segregated account established by the County. The design of the improvement, its cost, the surcharge and disbursements from the segregated account shall be approved by the Board of Supervisors.</p>	In Compliance. On-Going	On July 7, 2010, the County Board of Supervisors approved the establishment of a \$0.32 per ton fee ("Bailey Road Improvement Disposal Surcharge"), pursuant to Condition of Approval 29.6, of the Keller Canyon Landfill Land Use Permit 2020-89. On the same day the Board approved a \$0.68 per ton fee for Bailey Road Maintenance Disposal Surcharge, pursuant to Condition 29.7. This fee will be in effect between January 1, 2011 and December 31, 2015 and will be reduced to \$0.27 on January 1, 2016.

**EXHIBIT D - Compliance Status Table: Keller Canyon Landfill Land Use Permit 2020-89 Conditions of Approval**

Condition	Condition Description	Compliance Status	Comments
29.8	<p><b>Highway 4/Bailey Road interchange.</b> The Landfill developer shall participate in an improvements district, benefit area, or other cooperative arrangement with the County, the City of Pittsburg, and Caltrans which may be created to improve the Highway 4/Bailey Road Interchange. The developer shall be required to pay an amount for the improvements and maintenance proportionate to the traffic generated by the landfill, adjusted for truck use. If necessary, the developer shall advance the money for the interchange design and improvements. The County Public Works Department shall approve the design of the interchange and estimate its cost. The fees shall be paid quarterly into a segregated account established by the County. The design of the improvements, their costs, the surcharge, and disbursements from the segregated account shall be approved by the Board of Supervisors.</p>	Completed	<p>Originally included in FDIP, Section 11.5. An improvement district, benefit area, or other cooperative arrangement requiring the landfill developer participation was not established for the improvement of the Highway 4/Bailey Road Interchange.</p> <p>CalTrans constructed the Highway 4/Bailey Road interchange improvements in September 1992, which included the section of Bailey Road from the Highway 4 interchange south to Maylard Street.</p>
29.9	<p><b>Peak Period Traffic Management.</b> The Landfill operator shall prepare a study, in conjunction with the local transfer station(s) serving the landfill, for managing transfer vehicle traffic to reduce peak period conflicts with traffic on Highway 4. The study shall address the restricted departure periods from the Landfill identified in the Environmental Impact Report (6:30 - 8:30 a.m. and 3:30 - 6:30 p.m.) and shall identify any changes to the conditions of approval needed to implement a peak-period traffic reduction program. The study shall be approved by the County Public Works and Conservation and Development Departments and shall be provided with the Development and Improvements Plan. The Director of Conservation and Development has imposed the peak period traffic restrictions identified in a) and b) below. The Director of Conservation and Development may specify any additional peak period traffic restrictions deemed to be warranted. The Landfill operator shall comply with such restrictions, and shall require compliance in contracts with Landfill users.</p> <p>a) The A.M. peak period departure from the landfill shall commence at 7:10 a.m.                      b) A three minute interval shall be maintained between waste hauling vehicles en route to Highway 4 westbound during the period of 7:10 a.m. and 8:30 a.m.                      c) Waste hauling vehicles en route to eastbound Highway 4 (the uncongested "reverse commute" direction) may be released without restriction.</p>	Completed	<p>Included in FDIP, Section 11.6 and Appendix H. The peak period traffic management plan has been modified over time to reflect local traffic conditions. Conditional approval was issued in August 1996 to modify A.M. and P.M. peak period departure times (see Community Development Department letter from C. Zahn to S. Gordon (KCLC) dated 8/14/1996). A five (5) minute interval for departing trucks was approved for the periods of 7:30 A.M. to 8:30 P.M. and 3:30 P.M. to 6:30 P.M. Departure restrictions between 6:30 A.M. and 7:30 A.M. remained in effect. The revised intervals were subject to modification if dictated by traffic flow or a 25% increase in daily tonnage.</p> <p>Conditional Approval was issued by CDD in March 2000 to adjust departure time from 7:30 A.M. to 7:10 A.M.; and in April 2000 to reduce the interval of departing trucks in the A.M. peak period from 5 minutes to 3 minutes. See Community Development Department letter from D. Dingman to N. Christensen (KCLC) dated 4/27/2000. Modification of departure patterns improved efficiency of peak period truck traffic.</p>
29.10	<p><b>Bicycle and Pedestrian Improvements.</b> The Landfill developer shall incorporate into the Transportation and Circulation Plan a bicycle and pedestrian path system along Bailey Road in the vicinity of the landfill.</p>	Not Yet Required	<p>Plans for bicycle and pedestrian improvements are included in FDIP, Section 11.7, Figure 11-1. Staff reported to the Board of Supervisors on April 28, 1992 indicating that installation bike and pedestrian path between the City limits and the landfill entrance was determined to have limited functionality.</p>
30	<p><b>Objective.</b> The Landfill developer shall design, develop and manage the facility in such a manner that services and utilities adequately meet the landfills requirements, while ensuring the protection of site employees, area residents, and the surrounding environment.</p>	Objective	<p>This is solely an Objective. See Conditions 30.1 - 30.21.</p> <p>Implementation of conditions of approval in LUP Section 30. Site Services &amp; Utilities is expected to address the objectives of safety, efficient transport, and minimizing traffic impacts to area residents. The Site Services &amp; Utilities Plan is included in the FDIP, Sections 10.1 - 10.11..</p>

**EXHIBIT D - Compliance Status Table: Keller Canyon Landfill Land Use Permit 2020-89 Conditions of Approval**

Condition	Condition Description	Compliance Status	Comments
30.1	<p><b>Final Site Services and Utilities Plan.</b> The landfill developer shall prepare and submit a final Site Services and Utilities Plan, and obtain the approval of the County Conservation and Development Department prior to beginning construction. The Site Services and Utilities Plan shall be included in the Development and Improvements Plan. The final Site Services and Utilities Plan shall include:</p> <p>a) A water service component. (see Condition 30.2)                      b) A fire protection component. (see Condition 30.5)</p>	Completed	Implementation of Site Utilities Plan conditions of approval 30.2 - 30.21 meets landfill requirements and protects the surrounding environment. The Site Services and Utilities Plan is included in the FDIP, Sections 10.1 through 10.11, approved by the Community Development Department on 10/23/1991. Also RFPD letter from K. McCarthy to V. Conklin (CDD) dated 10/22/1991 in which RFPD approved compliance with Section 30 of the LUP.
30.2	<p><b>Water Service Component.</b> The Landfill developer shall prepare and implement a Water Service Component, covering available water resources, estimated total water needs and supplies, landfill construction and operation, landscaping, fire protection, employee hygiene, and human consumption water needs, and water supply sources. Potable water shall be provided for hygiene and consumption. Potable water may be trucked onto the Landfill.</p>	Completed	Included in FDIP, Section 10.1. Additional research and negotiations occurred following initial submittal in the FDIP in July 2014, documentation including numerous letters between the operator and City of Pittsburg are on file.
30.3	<p><b>On-site Water Wells.</b> The Landfill operator shall install wells for water supply with a minimum pumping capacity of 1,000 gallons per minute, or must have on-site storage which produces this capacity. The County Conservation and Development Department and Contra Costa Environmental Health shall be furnished pumping test information which shall be submitted with the Development and Improvement Plan.</p>	Completed	Also see Health Services Department Memo from C. Nicholson to C. Zahn (CDD) dated 3/10/1992, and Community Development Department Memo, V. Conklin to C. Zahn, dated 10/15/1991, and as updated through 10/25/1991.
30.4	<p><b>Public Water Supply Option.</b> The Landfill operator may substitute water service from a public water supply system for the use of wells, if arrangements can be made with the Contra Costa Water District and, where applicable with the cities of Concord or Pittsburg. The water supply may be potable or non-potable. Annexation to the Contra Costa Water District probably would be required, as well as an approval for annexation from the Local Agency Formation Commission, and would have to be obtained prior to the submission of the Water Service Plan as part of the Final Development and Improvements Plan. The size and placement at the water supply line shall be included in the Water Service Plan and shall be subject to the approval of the Contra Costa Environmental Health and Conservation and Development Departments.</p>	Not Yet Required	The option of a public water supply was not employed. The landfill Operator investigated the feasibility of this option in coordination with County agencies. A public water supply option was not feasible at the time of landfill construction due to design and infrastructure constraints. All on-site water needs are currently met with groundwater supplies. The Condition should be retained to allow for evaluation of future public water supply alternatives if necessary.
30.5	<p><b>Fire Protection Component.</b> The Landfill operator shall develop and implement a Fire Protection Component meeting the requirements of the applicable Fire Protection District to contain and extinguish fires originating on the landfill property and off-site fires caused by Landfill operations. It shall include training for all employees. The program shall be subject to the approval of Contra Costa Environmental Health.</p>	Completed. Updated As Needed	<p>The Fire Protection Component is included in FDIP, Section 10.3. The Riverview Fire Protection District (RFPD) indicated that the fire protection component had been adequately addressed and therefore authorized preliminary construction in a letter dated 10/21/1991. The Site Plan and Fire Protection Component were approved by RFPD. See RFPD letter from K. McCarthy to C. Nicholson (HSD) and C. Zahn (CDD) dated 3/4/1992. Final inspection of the entire fire protection system determined all requirements were met. Last inspection was on January 31, 2014.</p> <p>See Health Services Department Memo, C. Nicholson to C. Zahn (CDD), dated 10/24/1991 and Community Development Department Memo, V. Conklin to C. Zahn, dated 10/15/1991, and as updated through 10/25/1991.</p>



**EXHIBIT D - Compliance Status Table: Keller Canyon Landfill Land Use Permit 2020-89 Conditions of Approval**

Condition	Condition Description	Compliance Status	Comments
30.6	<b>Fire District Programs.</b> The Landfill developer shall participate in the Riverview Fire Protection Districts Benefit Assessment Program and the New Development Fees program.	In Compliance. On-going	The landfill operator participated in the New Development Fees program when applicable fees are assessed and paid at the time Building Permits were issued. A review of recent Property Tax Bills confirmed that the Fire District's Benefit Assessment program has yet to be established,
30.7	<b>Construction Timing.</b> Access roads and water supply systems shall be installed and in service prior to any combustible construction and/or related landfill activity. No construction, excavation, or grading work shall be started on this landfill facility until a plan for water supply system has been submitted to and approved by Contra Costa Environmental Health and the County Conservation and Development Department. Water may be transported onto the site during construction activities, but trucked water shall not be used for ongoing landfill activities.	Completed	Plans for access roads and water supply systems were approved prior to landfill operations. On-site water was to be supplied by wells. See Condition 30.3. Trucked water is used on paved and unpaved roads in accordance with dust suppression requirements of this LUP and in accordance with requirements of the BAAQMD Permit to Operate. See Condition 20.5.  See Health Services Department Memo, C. Nicholson to C. Zahn (CDD), dated 10/24/1991 and Community Development Department Memo, V. Conklin to C. Zahn, dated 10/15/1991, and as updated through 10/25/1991.
30.8	<b>On-Site Water Storage.</b> The Landfill developer shall provide an adequate and reliable water supply for fire protection which shall include on-site storage. The storage tank(s) shall have a useable capacity of not less than 240,000 gallons of water and shall be capable of delivering a continuous flow of 1,000 gallons per minute.	Completed	Plans used for conservation were dated 1/16/1992. Storage capacity is approximately 366,000 gallons and is capable of delivering a continuous flow of 1,000 gallons per minute in accordance with this LUP condition.  See Department of Community Development letter from C. Zahn to B. Olney dated 3/12/1992 which authorized installation of the water tank (Building Permit BP MI 176099); and letter dated 3/24/1992 which authorized installation of the pump house (Building Permit MI 176416).  See Health Services Department Memo, C. Nicholson to C. Zahn (CDD), dated 10/24/1991, and Community Development Department Memo, V. Conklin to C. Zahn, dated 10/15/1991, and as updated through 10/25/1991.
30.9	<b>Fire Fighting Water Main.</b> If the Landfill developer exercises the alternative of utilizing public water supply, an above-ground main of sufficient size and quantity shall be provided, which when connected to the respective storage tank, shall be capable of supplying the required portable monitor (see Condition 30.11) with a minimum fire flow of 1,000 GPM delivered to the working face of any open cell in the landfill operation.	Completed	The alternative of utilizing a public water supply was not implemented. The existing fire fighting system meets the minimum fire flow requirements of 1,000 GPM and was approved by County Riverview Fire Protection District.
30.10	<b>Fire Cover.</b> The Landfill operator shall store a supply of soil nearby the working face to be used for fire suppressant. The adequacy of the cover stockpile shall be determined by Contra Costa Environmental Health in cooperation with the applicable Fire Protection District.	Completed	Storage of soil near the working face for potential use as a fire suppressant is standard operating procedure.
30.11	<b>Fire Fighting Appliance.</b> The Landfill operator shall provide a minimum of one (1) approved portable master-stream firefighting appliance (monitor) located within fifty (50) feet of each work-ing face of any open cell in the landfill.	In Compliance. On-Going	A portable master-stream firefighting appliance is located near the working face as standard operating procedure in accordance with this LUP condition.

**EXHIBIT D - Compliance Status Table: Keller Canyon Landfill Land Use Permit 2020-89 Conditions of Approval**

Condition	Condition Description	Compliance Status	Comments
30.12	<p><b>Fire Breaks.</b> The Landfill developer shall provide and maintain firebreaks as follows: a) A minimum 100-foot firebreak around the perimeter of each landfill disposal area, b) A minimum 60-foot firebreak around the perimeter of the entire site and around any buildings or similar structures. The firebreaks shall be placed to minimize any adverse visual effects. Their locations shall be subject to the approval of the Riverview Fire Protection District. The firebreaks shall be included in the Development and Improvements Plan.</p>	In Compliance. On-Going	<p><b>UPDATE: Fire breaks were constructed in 2015 and 2016 in accordance with this condition.</b></p> <p>Fire breaks are maintained on a seasonal basis as standard operating procedure in accordance with requirements of the Riverview Fire Protection District.</p> <p>See Health Services Department Memo, C. Nicholson to C. Zahn (CDD), dated 10/24/1991, and Community Development Department Memo, V. Conklin to C. Zahn, dated 10/15/1991, and as updated through 10/25/1991.</p>
30.13	<p><b>Fire Extinguishers.</b> The Landfill operator shall provide landfill equipment with fire extinguishers large enough to fight small fires on the equipment or on the landfill. The extinguishers and their distribution shall be subject to the approval of Contra Costa Environmental Health and the applicable Fire Protection District.</p>	In Compliance. On-Going	<p>Fire extinguishers are located in onsite buildings, operating equipment and maintenance and support vehicles. See Condition 30.5.</p> <p>See Health Services Department Memo, C. Nicholson to C. Zahn (CDD), dated 10/24/1991, and Community Development Department Memo, V. Conklin to C. Zahn, dated 10/15/1991, and as updated through 10/25/1991.</p>
30.14	<p><b>Use of Reclaimed Water for Landscaping.</b> The Landfill Developer shall make every effort to use treated waste water from a district sewage treatment plant for landscape maintenance. The Landfill Developer shall report on this matter to the Conservation and Development Department</p>	In Compliance. On-Going	<p>Use of treated wastewater for landscaping was determined in December 1992 to be infeasible. In a letter from the landfill operator dated 9/24/1992, information was requested on availability and feasibility of treated waste water to meet an annual demand of approximately 1,050,000 gallons per year. Letters were sent to the Delta Diablo Sanitation District (DDSD) and Central Contra Costa Sanitary District (CCCSD).</p> <p>In December 1992, the landfill operator submitted a status report to the Community Development Department stating the annual water demand would have to be trucked from either DDSD or CCCSD for use at the landfill site. Neither the transportation/distribution system nor transport capacity existed to deliver the annual demand for water. The landfill operator stated that construction of a pipeline from DDSD to KCL would cost in the millions of dollars for development of a system, exclusive of right-of-way acquisition costs. The system would require necessary governmental and private approvals that were beyond the scope of the condition of approval. The landfill operator expressed a willingness to explore the option for use of reclaimed waste water should a pipeline delivery system become operational sometime in the future.</p> <p>See KCLC letter T. Cox (KCLC) to V. Conklin (CDD) dated 12/1/1992.</p>
30.15	<p><b>Equipment and Cleaning.</b> See Condition 20.24.</p>	Cross-Reference	<p>This condition cross-references another LUP condition. See Condition 20.24.</p>
30.16	<p><b>Smoldering Loads.</b> The Landfill operator shall check incoming loads and direct vehicles hauling smoking or burning trash to a designated place apart from the current fill area. The loads shall be dumped immediately and the fire extinguished before the waste is incorporated into the fill.</p>	In Compliance. On-Going	<p>The Load Check Program requires checking of all incoming vehicles hauling smoldering loads. Gate operator would notify site foreman at the working face of the need for special handling per this condition. Also see LUP Condition 7.1.</p>

**EXHIBIT D - Compliance Status Table: Keller Canyon Landfill Land Use Permit 2020-89 Conditions of Approval**

Condition	Condition Description	Compliance Status	Comments
30.17	<b>Emergency Equipment Access.</b> The Landfill operator shall designate access points for local fire protection agency access to all parts of the landfill and routes. The access points shall be included in the Development and Improvements Plan and shall be subject to the approval of the Riverview Fire Protection District.	In Compliance. On-Going	Designated emergency access points were approved by RFPD.  Approval by RFPD substantiated by CDD on 10/23/1991. See Health Services Department Memo, C. Nicholson to C. Zahn (CDD), dated 10/24/1991, and Community Development Department Memo, V. Conklin to C. Zahn, dated 10/15/1991, and as updated through 10/25/1991.
30.18	<b>Smoking Prohibitions.</b> The Landfill operator shall prohibit smoking on the landfill except in designated areas. In no event shall smoking be allowed near the working face of the landfill and the fuel storage area. Signs shall be clearly posted and enforced.	In Compliance. On-Going	On-site signage is installed that prohibits smoking in all landfill operations areas.
30.19	<b>Toilets.</b> The Landfill operator shall provide portable chemical toilets near the active disposal area for use of workers and drivers. Their placement and maintenance shall be subject to the approval of Contra Costa Environmental Health.	In Compliance. On-Going	Included in FDIP, Section 10.9. Placement of chemical toilets in safe and convenient locations is standard operating procedure within the disposal operations area and ancillary facilities.  Sanitary facilities are provided for employees and visitors at the landfill administrative building. Locker, rest room, and shower facilities are provided for employees in the maintenance building. Bottled drinking water is provided at the administrative building and maintenance building.
30.20	<b>On-site Septic System.</b> Septic systems shall be designed to County Department of Health Service Standards, and State Health and Safety Code requirements. The Landfill developer shall pay for any treatment plant fees.	In Compliance. On-Going	Septic systems were designed, approved, and constructed per County and State standards.
30.21	<b>Sewer Line.</b> In the event that the Landfill developer elects to connect to a sewer line, the developer shall pay for any capacity studies required, and any resultant equipment and/or facilities.	Completed	Landfill developer elected to construct an on-site septic system. Connection to a sewer line has not been determined to be necessary.
31.1	<b>Waste Reduction and Resource Recovery Objective.</b> The Landfill operator shall manage the facility in such a manner that complies with the State's waste management hierarchy of source reduction, recycling and composting, and environmentally safe transformation and land disposal; and that is consistent with the Countywide Integrated Waste Management Plan.	Objective	This is solely an Objective. See Conditions 31.2 - 31.10.  <b>UPDATE: Please see updates of Conditions 31.4 through 31.6 below.</b>  The Landfill operator generally manages the facility consistent with prevailing requirements of CalRecycle, the Countywide Integrated Waste Management Plan, and other permits. The Waste Reduction and Resource Recovery Program is included in the FDIP, Sections 6.1 through 6.5. Condition 17i (Waste Reduction and Resource Recovery) of the SWFP further requires that wastes transported by transfer vehicles should originate from transfer stations where waste reduction and recovery activities take place.
31.2	<b>1990-1995 Resource Recovery Program.</b> The Landfill Operator shall participate with the transfer station(s) operators(s), route collection companies and direct haulers in designing and implementing a resource recovery and recycling program for the service area which is consistent with the goal of diverting 25 percent of all solid waste generated in the County from landfill facilities by January 1, 1995.	Completed	The Resource Recovery Program for 1990-1995 is included in FDIP, Section 6.1. No substantive resource recovery activities were conducted at Keller.

**EXHIBIT D - Compliance Status Table: Keller Canyon Landfill Land Use Permit 2020-89 Conditions of Approval**

Condition	Condition Description	Compliance Status	Comments
31.3	<p><b>1996-2000 Resource Recovery Program.</b> Prior to 1995, the Landfill operator shall prepare and submit for review and approval by the County Conservation and Development Department a resource recovery and recycling program for the service area covering the period from 1996-2000. This shall be consistent with the County-wide Integrated Waste Management Plan's goal of diverting a total of 50 percent of all solid waste generated in the County from landfill facilities by January 1, 2000.</p>	Completed	<p>The Resource Recovery Program for 1996-2000 is included in FDIP, Section 6.2. Initiated on-site resource recovery activities authorized by regulatory changes allowing waste derived cover materials and beneficial reuse materials to be treated as diversion.</p>
31.4	<p><b>Materials Recovery.</b> The Landfill operator shall prepare and implement a Material Recovery Program for recovering recyclable materials (e.g. construction and demolition debris) from refuse loads brought directly to the landfill. The Program shall describe in detail all existing and proposed on-site recovery activities and the associated percent of waste diversion for each, including materials diverted for use as cover, on-site beneficial reuse as well as transported off-site (e.g. biomass facilities). The Program shall include proposed on-site recovery activities intended to handle source separated loads and comingled loads to be sorted on-site to increase diversion, if applicable. The Program shall be consistent with the Countywide Integrated Waste Management Plan. The landfill operator shall record and report the weight of all material(s) recovered through the Material Recovery Program. Each type of recovered material being diverted must be weighed for reporting purposes. Materials accepted for beneficial reuse or ADC, which are subsequently deemed unsuitable and must therefore be disposed of, shall be weighted and reclassified for the purposes of reporting and fee calculation. Incoming quantities required to be tracked and reported by waste type and jurisdiction of origin, pursuant to Conditions 8.7 and 10.3 must accurately differentiate between the tons disposed, beneficially used on-site or sent off-site. Quarterly disposal reports must also accurately reflect the destination and tonnage of each type of recovered material sent off-site, if applicable. The Program shall be subject to the approval of the County Department of Conservation and Development.</p>	Further Review Required	<p><b>UPDATE: Revised information was submitted to DCD in the Fall of 2016 with information intended to update what is specified in FDIP Section 6.3. Updated program information submitted in October 2016 is currently under review to determine what if any additional information may be needed to ensure consistency with current Countywide goals and requirements and intent of this condition.</b></p> <p>The initial Materials Recovery program was included in FDIP, Section 6.3. However, the Countywide Integrated Waste Management Plan was not approved by the State until 1993.</p>
31.5	<p><b>Composting Project.</b> The Landfill operator shall develop and implement a program for composting organic material. The program may occur at the landfill site, off-site or in coordination with third party(ies), and shall be approved by Contra Costa Environmental Health and the Department of Conservation and Development. The compost shall be used for landfill landscaping, cover material or other approved on-site uses; alternatively, compost can be made available or sold off-site. The purpose of the composting program shall be to implement a cost effective and feasible means of providing adequate local organics diversion capacity through large-scale composting. The composting operations shall be subject to regulatory and permitting requirements enforced by Contra Costa Environmental Health, the Air District and the Water Board. No later than January 1, 2016, the Landfill operator shall submit substantiation that they have applied for the required regulatory approvals (permits) processes necessary to conduct large-scale composting or demonstrate that arrangements are underway to implement an equivalent off-site program. The Landfill operator shall make all feasible efforts to assist the County in ensuring that there will be adequate composting capacity available to readily divert the organics waste stream generated in Contra Costa County which is currently used as Alternative Daily Cover (ADC) prior to the sunset of the ADC diversion credit on January 1, 2020.</p>	In Process	<p><b>UPDATE: Documentation was submitted to DCD in the Fall of 2016 with information intended to update what is specified in FDIP Section 6.4. In 2015, KCL received and used approximately 46,500 tons of greenwaste as ADC from locations in Contra Costa County. As of October 1, 2016 there are only three cities in the County which do not require that their franchise hauler compost the greenwaste collected curbside. One of those cities has committed to have their curbside greenwaste composted by 2018. Republic Services has adequate capacity to compost the greenwaste from the two remainign cities at their facilities in either North Richmond, Milpitas or Manteca. Updated program information submitted in October 2016 is still under review to determine what if any additional information may be needed to ensure consistency with current Countywide goals and requirements and the intent of this condition.</b></p> <p>A concept for a composting operation is included in FDIP, Section 6.4. The Pilot project was not implemented within 6 months of the landfill opening due to lack of market feasibility at the time of landfill construction and additional permitting requirements. Some compostable green waste has been diverted as Alternative Daily Cover since authorized to do so by CCEH starting with their 12-month Demonstration Project in April 1999.</p> <p>The majority of wood waste and material for composting is processed at the Contra Costa Transfer and Recovery station, where regular wood chipping occurs and greenwaste is transloaded for approved off-site uses. An off-site program has been formally proposed to County DCD in October 2014 involving use of the composting facility in operation at Republic Services' site in west Contra Costa County and the City of Richmond (Bulk Material Processing Center approved under County LUP 2054-92, and in accordance with the Standardized Composting Permit under that facility's SWFP 07-AA-0044).</p>

**EXHIBIT D - Compliance Status Table: Keller Canyon Landfill Land Use Permit 2020-89 Conditions of Approval**

Condition	Condition Description	Compliance Status	Comments
31.6	<p><b>Wood Chipping.</b> The Landfill operator shall establish a program to encourage landscape services and construction/demolition debris haulers to segregate wood material for chipping and diversion from landfill disposal. The program may occur off-site, however unless and until there is on-site recovery (waste diversion as defined in the Integrated Waste Management Act) the Landfill operator shall direct these customers to deliver loads of landscaping and construction/demolition debris to facility(ies) that recover and chip wood material. The program shall be submitted for review and approval by the County Department of Conservation and Development and implemented on an ongoing basis following approval.</p>	Further Review Required	<p><b>UPDATE: Revised information was submitted to DCD in the Fall of 2016 with information intended to update what is specified in FDIP Section 6.5. Updated program information submitted in October 2016 is currently under review to determine what if any additional information may be needed to ensure consistency with current Countywide goals and requirements and the intent of this condition.</b></p> <p>A wood chipping concept is included in the FDIP, Section 6.5. A wood chipping program was not placed in operation within six months of the landfill's opening.</p> <p>DCD issued Conditional Approval for implementation of a wood chipping operation on August 21, 2003 based on consistency with the LUP 2020-89 Condition of Approval 31.6 Waste Reduction and Resource Recovery – Wood Chipping. The wood chipping operation was never implemented on-site. The majority of wood waste is processed at the Contra Costa Transfer and Recovery station, where regular wood chipping occurs.</p>
31.7	<p><b>Methane Recovery.</b> The Landfill operator shall explore the use of methane in landfill gas collected for air pollution reduction as a fuel commodity. The operator shall report findings to the Conservation and Development Department at the time of the landfill's periodic reviews. If there is an economic use found for recovered methane, and if the County subsequently includes the use in its Integrated Waste Management Plan, the Landfill operator shall implement a methane recovery program.</p>	Completed	<p>A landfill gas power plant was determined by the landfill operator to be feasible in August 1998. The LFGTE power plant became operational in 2009 and is addressed in Section 36. Landfill Gas Plant of this LUP. See Condition 20.13.</p>
31.8	<p><b>Equipment Maintenance.</b> The Landfill operator shall maintain motorized landfill equipment to assure maximum fuel efficiency.</p>	In Compliance. On-Going	<p>Equipment maintenance is performed according to manufacturer specifications and at required intervals. Maintenance records are maintained by the operator and available for review by County agencies. See LUP Condition 20.24</p>
31.9	<p><b>County Resource Recovery Management Program.</b></p> <p>a) When directed by the County, the Landfill operator shall impose a tonnage surcharge adequate to support a County Resource Recovery Management Program. The cost of the program to be supported by the surcharge shall not exceed \$100,000 at 1987 levels. If other solid waste disposal facilities are subject to this or a similar condition, the County may pro-rate the cost of the program among them according to a formula approved by the Board of Supervisors.</p> <p>b) As provided for in Condition 2.3, where there is an inconsistency between this condition and the terms of the Landfill Franchise Agreement which effectively suspended the collection of this Resource Recovery Management Program Fee, the terms of the Landfill Franchise Agreement shall supersede Condition 31.9 (a) until such inconsistency no longer exists pursuant to Condition 2.3(d).</p>	In Compliance. On-Going	<p>In 1994, the Board of Supervisors approved the First Amended Landfill Franchise Agreement which included a provision specifying that the Franchise Surcharge to be paid by the operator would cover the cost of all current County programs (required or authorized by the Use Permit or the Agreement) except the LEA and AB939 Fees.</p>
31.10	<p><b>Fund Recovery.</b> The Landfill owner may recover funds provided to the County in advance of the opening of the Landfill through subsequent rate adjustments or surcharges approved by the County. The County may pro-rate the cost of the program among other waste disposal facilities it approves which are subject to similar conditions.</p>	No Longer Applicable	<p>Condition Acknowledged.</p>

**EXHIBIT D - Compliance Status Table: Keller Canyon Landfill Land Use Permit 2020-89 Conditions of Approval**

Condition	Condition Description	Compliance Status	Comments
32.1	<b>Hours of Construction.</b> The Landfill developer shall restrict outdoor construction activities to the period from 8:00 a.m. to 6:00 p.m. Monday through Saturday.	In Compliance. On-Going	Outdoor construction activities are restricted to the hours and days specified in this LUP condition and Section 5b of the SWFP.
32.2	<b>Exemption.</b> The Landfill developer may request, in writing, and the Director of Conservation and Development may grant, exemptions to Condition 32.1 for specific times for cause. An example is the placing of concrete.	In Compliance. On-Going	During certain phases of the landfill's development, the developer has been granted exemptions pursuant to this Condition when circumstances warranted in response to written requests that were received by County DCD.
32.3	<b>Access Roads.</b> Before commencing landfilling operations, the Landfill developer shall install and pave the site access road from Bailey Road to the Phase I excavation area (see Initial Facilities Site Plan drawing of the Initial Development and Improvements Plan, Condition 16.1). This installation shall include the new bridge over Lawlor Creek and the turnaround lane. An area which can be used by the California Highway Patrol for vehicle inspection/weighing shall also be constructed.	Completed	Included in FDIP, Section 11.1, Drawings 8-13, approved by the Community Development Department on 10/25/1991.
32.4	<b>Phasing Plan.</b> The Landfill developer shall design a Phasing Plan setting forth a schedule of construction activities and projects, with detailed information provided on sensitive installations such as the landfill liner and the leachate collection and gas management systems. Sensitive installation projects shall be subject to inspection by the Geotechnical Inspector (Condition 23.6). The necessary installations of the Surface Drainage System (Condition 18.2) and Soil Erosion and Control Plan (Condition 18.4) shall be in place before major excavations commence in order to ensure controlled surface water runoff. Sediment in the sedimentation pond shall be monitored to control quality of runoff. Construction activities shall be timed to coincide with the dry season and low surface water flows.	Completed	Included in FDIP, Section 3.1 (Drawings 25-38)  The Phasing Plan was approved by CDD on 10/25/1991. See Community Development Department Memo, V. Conklin to C. Zahn, dated 10/15/1991, and as updated through 10/25/1991.
32.5	<b>Unstable areas.</b> Areas determined to be unstable by the Stability Analysis performed for the landfill (condition 18.4) shall be excavated or retaining walls installed under the supervision of a Certified Engineering Geologist or a Registered Geotechnical Engineer.	Completed. Updated As Needed	Evaluation of unstable areas is an on-going activity at KCL. Each design phase considers use of buttresses and other practices required for cell stability. All design and construction quality assurance documents are submitted to and approved by the RWQCB. Also see LUP Condition 16.12.
32.6	<b>Dust Suppression.</b> The developer shall sprinkle or chemically treat graded areas, borrow sites, stock piles, and temporary pavements to control dust, as determined necessary by Contra Costa Environmental Health and the Bay Area Air Quality Management District.	In Compliance. On-Going	Dust suppression is performed in accordance with this LUP condition and LUP Condition 20.5, Condition 17k(d) of the SWFP, and requirements of Condition #17309 of the Major Facility Review permit issued by BAAQMD.  See Health Services Department Memo from C. Nicholson to C. Zahn (CDD) dated 3/10/1992.

**EXHIBIT D - Compliance Status Table: Keller Canyon Landfill Land Use Permit 2020-89 Conditions of Approval**

Condition	Condition Description	Compliance Status	Comments
33.1	<p><b>Submittal of Plan.</b> The Landfill operator shall submit to the San Francisco Regional Water Quality Control Board, the California Department of Resources Recycling and Recovery, and Contra Costa Environmental Health a plan for the closure and the postclosure maintenance of the landfill as required by State law, but no later than upon application for a Solid Waste Facilities Permit. A copy of the closure and postclosure maintenance plan shall be submitted to the County Conservation and Development Department.</p>	In Compliance. On-Going	<p><b>UPDATE: In January 2016, CalRecycle issued a notice of violation specifically addressing the Closure/Post-Closure Maintenance Plans which stated: "The current Plans are inadequate. The operator needs to submit new, revised plans that reflect the current status of the Landfill. The Plans must be developed based on current regulations and local standards. Many of the appendices to the Plans are based on outdated data and standards that are more than 30 years old." KCL submitted the documentation needed and CalRecycle confirmed receipt and did not request anything further.</b></p> <p>Initial plans submitted September 30, 1994; Approved by RWQCB on November 28, 1994 (See RWQCB Letter from R. McMurtry to S. Mann (CIWMB) dated 11/28/1994). A Preliminary Closure and Post-Closure Maintenance Plan have been submitted pursuant to Title 27 CCR 21780.</p> <p>See Health Services Department Memo from C. Nicholson to C. Zahn (CDD) dated 3/10/1992.</p>
33.2	<p><b>Funding of Closure and Postclosure Maintenance Plan.</b> The Landfill operator shall submit to the Board of Supervisors or California Department of Resources Recycling and Recovery (CalRecycle) evidence of financial ability to provide for the cost of closure and postclosure maintenance in an amount not less than the estimated cost of closure and 15 years of postclosure maintenance as contained in the submitted closure and postclosure maintenance plan unless otherwise required by the State. Evidence of financial ability shall be in the form of a trust fund approved by the Board of Supervisors in which funds will be deposited on an annual basis in amounts sufficient to meet closure and postclosure costs when needed unless an equivalent financial arrangement is identified as acceptable to the Board of Supervisors. The Board of Supervisors determined that the State required financial guarantees approved and periodically reviewed by CalRecycle are equivalent and therefore adequate to satisfy this condition. The Landfill operator shall maintain a trust fund balance that equals or exceeds the requirements of state law or regulation notwithstanding, however, the trust fund balance shall be at least equal to the then current closure and postclosure cost estimate at such time the landfill has reached one-half of its permitted capacity. The Trust Fund balance requirement shall be appropriately adjusted if the landfill is closed in stages under Condition 33.4.</p>	Completed. Updated As Needed	<p><b>UPDATE: The landfill operator fulfilled financial assurance requirements for closure and post-closure funding for 2015. A Financial Assurance Letter and surety bonds were submitted to meet the requirements of Title 27, California Code of Regulations, Section 22244 (a) and (c).</b></p> <p>KCLC provided evidence of financial ability to SFRWQCB &amp; HSD in a letter and supporting documentation dated October 24, 1991.</p> <p>Landfill facility bonds for closure, post-closure, and corrective action are updated annually according to inflation rates set by CalRecycle. CalRecycle issues letters after reviewing bonds submitted to confirm if they adequately satisfy regulatory requirements. These details are noted in the annual Activities Reports now regularly being submitted by the operator, along with copies of the surety bonds submitted to CalRecycle..</p> <p>See Health Services Department Memo, C. Nicholson to C. Zahn (CDD), dated 10/24/1991, and Community Development Department Memo, V. Conklin to C. Zahn, dated 10/15/1991, and as updated through 10/25/1991.</p>
33.3	<p><b>Revision to Plan and Cost Estimates.</b> Should State law or regulation regarding the closure and postclosures maintenance plan or funding of the plan change at any time, the owner of the landfill shall submit any required changes to the closure and postclosure maintenance plan and/or evidence of financial ability to the Board at the same time as submittal to the applicable state or regional agency.</p>	Completed. Updated As Needed	<p>CCR Title 27 now requires that landfill operators update financial assurances (bonds) for closure and post-closure annually, according to inflation rates set by CalRecycle. Copies are included as attachments to the annual Activities Report submitted to the County.</p>
33.4	<p><b>Staged Closure of the Landfill.</b> The landfill owner or operator shall close the landfill in stages if compatible with the filling sequence and the overall closure plan.</p>	Not Yet Required	<p>Condition acknowledged.</p>
33.5	<p><b>Use of Landfill Following Closure.</b> After active landfill operations have ceased, the site shall be utilized for grazing purposes. The Board may require the owner of the landfill to deed all development rights for the landfill site to the County to ensure fulfillment of this condition.</p>	Not Yet Required	<p>Landfill lifespan is projected to continue for an additional 30 to 35 years or more depending on operating assumptions.</p>

**EXHIBIT D - Compliance Status Table: Keller Canyon Landfill Land Use Permit 2020-89 Conditions of Approval**

Condition	Condition Description	Compliance Status	Comments
33.6	<p><b>Postclosure Maintenance.</b> The Landfill operator shall institute a postclosure maintenance program to ensure that containment and monitoring facilities retain their integrity. If damaged areas are found, the operator shall notify the County and take remedial actions to prevent odor and landfill gas problems.</p>	Not Yet Required	<p><b>UPDATE: The JTD for Keller Canyon Landfill was updated in May 2016 and filed with Contra Costa Environmental Health, CalRecycle and County DCD.</b></p> <p>The Preliminary Closure and Post-Closure Maintenance Plans are presented in <b>May 2016</b> Draft JTD, Volume 1, and were prepared in accordance with 27 CCR, Sections 21769(b) and 21790.</p>
34.1	<p><b>Storage Requirement.</b> The Landfill operator shall provide a minimum 10-acre area on the landfill site for the storage of abandoned vehicles awaiting salvaging, if required by the Board of Supervisors. The storage site operator shall accept only vehicles directed to the site by a law enforcement agency operating in Contra Costa County, which shall be responsible for the vehicle until its title is conveyed to a salvager. The site would provide storage only; operations of disposing, salvaging, and security of abandoned vehicles shall not be the responsibility of the operator. The site may be subject to further planning and development approvals, and would be subject to the California Environmental Quality Act. The storage of abandoned vehicles shall be subject to conditions set by Contra Costa Environmental Health, and may be subject to the approvals of regulatory agencies having jurisdiction.</p>	Not Yet Required	<p>Implementation of this condition is not yet required due to a lack of demand. The County Sheriff's Department coordinates storage of abandoned vehicles at other facilities prior to final demolition and transport. Operator does not propose to store abandoned vehicles at the landfill without authorization from the County.</p>
34.2	<p><b>Off-site Storage Option.</b> The Landfill operator may establish the abandoned vehicle storage area at another location, which shall be subject to the approval of the County Conservation and Development Department.</p>	Not Yet Required	<p>Implementation of this condition is not yet required. No requests have been received from the County Sheriff's Department for the Operator to establish an off-site abandoned vehicle storage area.</p>
35.1	<p><b>Transportation System Impact Fee:</b> The Landfill operator shall pay to the County of Contra Costa a Transportation Impact Fee of \$2.00 per ton of waste received at the Landfill to mitigate the general impacts of the Landfill-generated traffic on the County's road system. The operator shall deposit the fee monies quarterly in a segregated account established by the County. The fee shall be considered to be a pass-through business cost for the purposes of rate setting. The fee shall be adjusted annually to reflect the current Consumer Price Index.</p>	Cross-Reference	<p>This condition cross-references another LUP condition, in effect it has been superceded by Condition 35.8. The Board of Supervisors approved Amendment 1 to Land Use Permit 2020-89 on November 1, 1994 which stayed the operation of this Condition as long as the <u>new</u> Condition 35.8 remains in full force and operation.</p> <p>Mitigation fees have been paid to the County since the landfill opened on May 7, 1992.</p>
35.2	<p><b>Open Space and Agricultural Preservation Fee.</b> The Landfill operator shall pay to the County of Contra Costa an Open Space and Agricultural Preservation Fee of \$2.00 per ton on solid wastes received at the Landfill to mitigate the general impacts of the Landfill on open space, existing and proposed recreational facilities, and agriculture. The operator shall deposit the fee monies quarterly in a segregated account established by the County. The fee shall be considered to be a pass-through business cost for the purposes of rate setting. The fee shall be adjusted annually to reflect the current Consumer Price Index.</p>	Cross-Reference	<p>This condition cross-references another LUP condition, in effect it has been superceded by Condition 35.8. The Board of Supervisors approved Amendment 1 to Land Use Permit 2020-89 on November 1, 1994 which stayed the operation of this Condition as long as the <u>new</u> Condition 35.8 remains in full force and operation.</p> <p>Mitigation fees have been paid to the County since the landfill opened on May 7, 1992.</p>



**EXHIBIT D - Compliance Status Table: Keller Canyon Landfill Land Use Permit 2020-89 Conditions of Approval**

Condition	Condition Description	Compliance Status	Comments
35.3	<p><b>Property Value Compensation Program.</b> The Landfill operator shall provide funding for the preparation of a property value compensation program study when requested by the County of Contra Costa. The study will address the means of determining the extent of property value losses or reductions attributable to Landfill impacts, such as aesthetics, noise, traffic, or pollution, and the means of compensating property owners for said losses or reductions. When a compensation program is adopted by the Board of Supervisors, the Landfill developer shall fund it in the manner specified by the Board. If the Board of Supervisors determines that progress on the implementation of a compensation program is not proceeding in a timely manner, the Board may require the use of a facilitator and/or an arbitrator. The fee shall be considered to be a pass-through business cost for the purposes of rate setting.</p>	Completed	The County issued payments totaling approximately \$476,400 to property owners near the Keller Canyon Landfill as part of the Keller Canyon Landfill Property Valuation Mitigation Claim Process adopted by the Board of Supervisors. The Board approved the program in 1997 after several studies and multiple hearings related to LUP condition of approval 35.3.
35.4	<p><b>Resource Recovery Program Fee.</b>                      a) The Landfill developer or operator shall pay to the County of Contra Costa a resource recovery program fee of \$200,000 annually, beginning July 1, 1990. The developer or operator shall deposit the monies in a segregated account established by the County. The extent of the fee shall be subject to reconsideration when a franchise or agreement is established for the Landfill. The resource recovery program fee from its inception shall be a pass-through business cost for the purpose of rate setting. The fee shall be adjusted annually to reflect the current Consumer Price Index.                      b) As provided for under Condition 2.3, where there is an inconsistency between this condition and the terms of the Landfill Franchise Agreement which effectively suspended this Resource Recovery Program Fee, the terms of the Landfill Franchise Agreement shall supersede Condition 35.4 (a) until such inconsistency no longer exists pursuant to Condition 2.3(d).</p>	No Longer Applicable	In 1994, the Board of Supervisors approved the First Amended Landfill Franchise Agreement which included a provision specifying that the Franchise Surcharge to be paid by the operator would cover the cost of all current County programs (required or authorized by the Use Permit or the Agreement) except the LEA and AB939 Fees.
35.5	<p><b>Violation of Prescribed Haul Route.</b> Upon a receiving a written determination from the County that a user of the Landfill has violated Condition 29.2 by using a prohibited access route, the Landfill operator shall impose on that user the sanction that is directed by the County. Such sanction may include a surcharge on the tipping fee, prohibition against accepting waste from that user for a designated period of time, revocation of County refuse-hauling license, or other sanction directed by the County. A system for reporting alleged violation and for monitoring enforcement data shall be established by the County and implemented by the Landfill operator.</p>	In Compliance. On-Going	<p><b>UPDATE: There have been no violations of the prescribed haul route in 2015.</b></p> <p>The facility is in compliance with this condition. No sanctions have been imposed for violation of the prescribed haul route.</p>
35.6	<p><b>Direct Property Acquisition Study.</b> The Landfill operator shall study the appropriateness of direct acquisition of properties immediately adjacent to the project, and shall fund any acquisition program ordered by the Board of Supervisors. The study shall be consistent with the Environmental Impact Report and shall be completed prior to the issuance of a franchise agreement.</p>	Not Yet Required	Condition Acknowledged. No acquisition program has been ordered by the Board of Supervisors.

**EXHIBIT D - Compliance Status Table: Keller Canyon Landfill Land Use Permit 2020-89 Conditions of Approval**

Condition	Condition Description	Compliance Status	Comments
35.7	<b>Adjoining Sites.</b> This permit authorizes the use of the Keller Canyon Landfill site only for its specified waste disposal uses as set forth in these Conditions of Approval, and for no other uses. In particular, during the effective and operative periods of this Permit, the Keller Canyon site covered by this Permit shall not be used to provide access to, or to accommodate in any way the use of, any adjoining property for landfill purposes, unless the County has approved the use of such adjoining property for landfill purposes.	Informational	Condition Acknowledged. KCL site has not been proposed or used to provide access to or accommodate use of adjoining property for landfill purposes.
35.8	<b>Mitigation Fee.</b> The Landfill operator shall pay to the County of Contra Costa a fee, the amount of which may be set by the Board of Supervisors by a Board Order from time to time, which amount shall not be less than \$3.00 per ton and shall not be more than \$4.00 per ton, on solid waste received at the Landfill. The fee shall be used as directed by the Board in its sole discretion: 1) to mitigate general impacts of the Landfill-generated traffic on the County's road system, 2) to mitigate the general impacts of the Landfill on open space, existing and proposed recreational facilities, and agriculture, or 3) to mitigate any general impacts of the Landfill upon the surrounding community. Conditions 35.1 and 35.2 of Land Use Permit 2020-89 are hereby stayed in their operation as long as Condition 35.8 remains in full force and operation. Should Condition 35.8 (or any portion of it) for any reason be set aside or stayed in its operation, then Conditions 35.1 and 35.2 shall be in full force and operation.	In Compliance. On-Going	This Condition was added by Amendment 1 to Land Use Permit 2020-89 which the Board of Supervisors approved on November 1, 1994. A fee of \$3.00 per ton has been collected since landfill opening, of which \$1.75 per ton is allocated to the County, and \$1.25 per ton is allocated to the City of Pittsburg. The County Board of Supervisors awards grants from the Keller Canyon Landfill Mitigation Fund to County agencies and community-based organizations in the Bay Point and Pittsburg communities. Grants totaling \$1,292,081 were awarded in the 2013-2014 fiscal year.
36.1	<b>Power Plant Design.</b> The design of the Landfill Gas Power Plant project as approved is generally shown on the plans submitted to the Conservation and Development Department on October 16, 2001.	Informational	Condition Acknowledged.
36.2	<b>Ultimate Responsibility.</b> These conditions of approval identify the Landfill Gas Power Plant operator as the party primarily responsible for implementing conditions involving the design, construction, improvements, maintenance and management of the power plant. However, ultimate responsibility for compliance with these conditions lies with the owner of the landfill.	Informational	Condition Acknowledged. Landfill Gas Power Plant (building and equipment) is owned and operated by Ameresco Keller Canyon L.L.C.
36.3	<b>Keller Canyon Landfill Land Use Permit.</b> The construction and operation of the Landfill Gas Power Plant is also subject to all other conditions in Land Use Permit 2020-89 for the Keller Canyon Landfill, as appropriate.	Informational	Condition Acknowledged.
36.4	<b>Violation/Revocation.</b> The Landfill Gas Power Plant owner and operator shall at all times comply with the provisions and requirements of these Conditions of Approval. A repeated violation of any of these Conditions as a result of the construction or operation of the Power Plant is cause for revocation of the Land Use Permit for the power plant.	In Compliance. On-Going	There have been no violations of conditions of approval in Section 36. Landfill Gas Power Plant
36.5	<b>System Safety.</b> Risk of fire (from gas, oil, or electrical sources) shall be controlled through the use of flame sensors, ultraviolet (UV) radiation and methane detectors, and fire extinguishers. These components shall be installed at a minimum, in the power modules, exhaust and cooling packages, and other locations as required by Code.	In Compliance. On-Going	Facility Safety System was designed and installed in accordance with this LUP condition and other requirements of the County Building Inspection Department and Riverview Fire Protection District.
36.6	<b>Equipment and System Monitoring.</b> Instrumentation shall be provided for all power plant equipment and systems which provide for a fully automated monitoring and warning system. This will include an automated switch to combustion flare if necessary. Additionally, routine monitoring of the gas extraction system and power plant facility shall be performed during normal business hours by at least one on-site operator.	Completed. On-Going	Equipment and System Monitoring was designed and installed in accordance with this LUP condition and other requirements of the County Building Inspection Department and County Fire Protection District.

**EXHIBIT D - Compliance Status Table: Keller Canyon Landfill Land Use Permit 2020-89 Conditions of Approval**

Condition	Condition Description	Compliance Status	Comments
36.7	<b>Engines.</b> Power plant facilities shall use lean burn internal combustion engines to meet BAAQMD regulations for oxides of nitrogen (NOx), carbon monoxide (CO) and volatile organic compounds (VOC).	Completed. On-Going	Engines meeting the requirements of this condition were installed in accordance with requirements of the BAAQMD.
36.8	<b>Hazardous Materials.</b> Landfill Gas Power Plant operator shall prepare and submit a Hazardous Materials Business Plan for the Power Plant in compliance with requirements of the Hazardous Materials Division of Contra Costa County's Health Services Department.	Completed. On-Going	Ameresco Keller Canyon LLC submitted the Hazardous Materials Business Plan to the County DCD and HSD-Hazardous Materials Division in October 2009.
36.9	<b>Emergency Response.</b> Landfill Gas Power Plant operator shall submit a facility specific Emergency Response Plan and then implement and update as needed, said Plan.	Completed. On-Going	Ameresco Keller Canyon LLC submitted the Emergency Response Plan to the County DCD and Contra Costa Environmental Health in October 2009.
36.10	<b>Notification of Plant Upset or Accidental Release.</b> Landfill Gas Power Plant operator shall notify the Conservation and Development Department immediately of any plant upset or accidental leakage or release of landfill gas. A written report of the cause of any plant upset and the corrective measures taken by the facility operator, shall be provided to the Conservation and Development Department within 72 hours after resolving an emergency.	Not Yet Required	Condition Acknowledged. To date there have been no incidents of plant upset or accidental leakage or release of landfill gas.
36.11	<b>Stormwater Pollution Prevention Plan (SWPPP).</b> Landfill Gas Power Plant operator shall implement the Keller Canyon SWPPP (prepared in 1996 and as may be amended from time to time), for water resources protection measures in case of spill of coolant, oil, or other lubricant.	In Compliance. On-Going	The landfill operator complies with the current SWPPP for the site. Any stormwater from the landfill gas power plant is included in the site drainage system in accordance with the WDRs and SWPPP. The landfill gas power plant processes do not use or discharge water, and a SWPPP specifically for the landfill gas power plant does not exist. For addressing potential spills of operating fluids, the landfill gas power plant operator submits annual plans and reports to Contra Costa Health Services in compliance with the California Environmental Reporting System (CERS). The plant's CERS ID for CCEH's California Accidental Release Prevention Program (CUPA) is 10479961. See AMERESCO (Keller Canyon, LLC) Industrial Storm Water Pollution Prevention Plan dated October 2009.
36.12	<b>Facility Design.</b> Power Plant facilities shall be painted Bronze Olive or other suitable color as approved by the Conservation and Development Department. Power Plant operator shall install a perimeter security fence to enclose the power plant.	Completed	Building color was approved by the County and a perimeter fence was constructed.

**EXHIBIT D - Compliance Status Table: Keller Canyon Landfill Land Use Permit 2020-89 Conditions of Approval**

Condition	Condition Description	Compliance Status	Comments
36.13	<p><b>Power Plant Landscape Plan.</b> A Landscape Plan for the Power Plant site shall be submitted subject to the approval of the Conservation and Development Department. The location and types of landscaping proposed along the security fence shall be specified.</p>	In Process	<p><b>UPDATE:</b> The original landscaping that was installed to meet this condition died as a result of California's drought conditions. Although the view of the proposed power plant and the other landfill environmental management facilities from neighboring residences is obstructed by topography, KCL is working with Ameresco, the operator of the LFG Power Plant to develop a new landscape plan in accordance with this condition. The landscape plan will identify use of California native, drought-tolerant plants along security fence. The plan is expected to be submitted to the County for review by the first week of December 2016.</p> <p>Landscaping Plan initially submitted in 2006 and again along with other plans/drawings submitted in order to have the Building Permit(s) issued in 2007.</p>
36.14	<p><b>Construction.</b> Upon completion of construction, all construction materials, including packaging materials, worker facilities, and debris will be removed from the site. Additionally during construction all excess materials shall be removed periodically, as needed.</p>	Completed	Construction materials were removed from the site upon completion of construction per this condition.
36.15	<p><b>Material Recycling.</b> Whenever feasible, all oils, lubricants, and coolant shall be recycled rather than disposed. Prior to issuance of a building permit, the applicant shall submit a Debris Recovery Plan. Upon completion of construction, the applicant shall submit a Debris Recovery Report.</p>	Completed	A Debris Recovery Plan was submitted to the Community Development Department on January 11, 2007 and approved by the department on January 12, 2007 (CDD Letter from L. Thompson to Ameresco). All oils, lubricants, and coolants are recycled. Final inspection hold was released at the time the Debris Recovery Report was submitted, however staff has been unable to locate hardcopy documentation.
36.16	<p><b>Implementation &amp; Compliance Monitoring.</b> The operator shall provide payment for costs associated with the Conservation and Development Department's monitoring of implementation and compliance with these Conditions of Approval.</p>	In Compliance. On-Going	Landfill gas power plant operator has issued any payments required for DCD monitoring costs.
36.17	<p><b>Surcharge.</b> A surcharge, if established by the County Board of Supervisors, shall be paid to the County, by the operator, related to the sale of landfill gas or the sale of electricity produced by burning said gas.</p>	In Compliance. On-Going	The County Board of Supervisors established a 1.5% surcharge at the time the Landfill Gas Power Plant was approved which began operation in 2009. This 1.5% surcharge of gross revenue is for the period of year one through ten of the project operations and raised to two percent 2% of gross revenue during year eleven through the life of the project. Landfill gas power plant operator has routinely issued payment as required by this condition.

# Lisa Della Rocca

209 Havenwood Circle® Pittsburg, CA 94565-7363® Phone: 925.698.1551

November 1, 2016

Chair Candace Andersen  
Members of the County Board of Supervisors  
Contra Costa County  
651 Pine Street, First Floor  
Martinez, California 94553

## Re: Agenda Item: D.6 – Permit Review of Keller Canyon Landfill Land Use Permit

Dear Chair Andersen and Members of the County Board of Supervisors:

I am writing to provide comments regarding the Contra Costa County Board of Supervisors’ [“Board”] Review of Keller Canyon Landfill’s [“KCL”] Land Use Permit [“LUP”], which is set for public hearing before the Board on the above-referenced date.

### REMAINING COMPLIANCE ISSUES

To start, I would like to say that it is apparent from the Staff Report for Agenda Item D.6 [“Staff Report”] that County staff has put a lot of time and effort into preparing its review of KCL’s LUP. It is not my intent in any way to diminish or disparage the hard work that went into preparing the Staff Report. That being said, there are a number of subjects discussed in the Staff Report that I feel warrant further explanation in order to have a complete picture of the status of the landfill’s compliance with its LUP. These subjects include, but are not necessarily limited to, odor and other health issues, direct haul compliance, and material recovery operations.

### ODOR

With regard to odor issues, as a resident of Pittsburg, a community deeply impacted by the presence of the landfill and the activities that take place there, I know from personal experience that odor from the landfill is a major problem in the area and that it largely goes unreported. I am one of those people that do not report the odor from the landfill. If I did, I probably couldn’t get much of anything else done.

Staff indicates that it reviewed odor complaints<sup>1</sup> received by the Contra Costa County Department of Conservation and Development [“DCD”], the Contra Costa County Department of Environmental Health [“LEA”], the Bay Area Air Quality Management District [“BAAQMD”], and KCL.<sup>2</sup> In addition, staff indicates that KCL performs routine patrols of the area including local neighborhoods for any indication of odors.<sup>3</sup> Staff further states that findings and results from the surveys conducted by KCL are documented daily.<sup>4</sup>

<sup>1</sup> It is worth noting that in early 2015 the DCD setup an online form for reporting odors and as a result there have been 15 odor complaints received by the DCD since that time. (Staff Report, p. 11.) This is a sharp increase from the 2 odor complaints reported in permit review for KCL performed in 2014. (Staff Report for the Keller Canyon Landfill Permit Review before the Contra Costa Planning Commission, dated October 28, 2014 [“2014 Permit Review”], p. 13.)

<sup>2</sup> Staff Report, pp. 11-12, Exhibit D, p. 30.

<sup>3</sup> Staff Report, p. 12, Exhibit D p. 30.

<sup>4</sup> Staff Report, p. 12, Exhibit D p. 30.

However, staff did not indicate whether it reviewed the daily odor patrol logs maintained by KCL and did not discuss the findings and implications of the data contained within said logs. Moreover, staff did not address the issue of unreported incidents of odor. Specifically, staff did not discuss any statistical correlation between reported incidents of odor and those that go unreported.

It is important that odor complaints are given the attention and credence that they deserve in order to ensure that proper enforcement action and mitigation efforts can be taken, particularly for a facility tasked with the management of solid waste and minimizing potentially hazardous environmental impacts. Demonstrative of the odor issue is the infestation of thousands of seagulls that live in the landfill, whose mainstay is the direct haul garbage that isn't properly processed and doesn't belong in a landfill. They smell the garbage, they flock to the landfill and spill over into the Oak Hills Shopping Center, where our families shop and eat. It's disgusting.

Moving forward, further analysis and context should be given to the odor issues associated with Keller Canyon landfill. I urge the Board to direct staff to review and report back on the data maintained in KCL's daily odor patrol logs and to address the issue of unreported incidents of odor, if not as part of this review then moving forward for all permit reviews to follow.

#### **DIRECT HAUL**

With regard to the direct hauling of waste to KCL, staff states "the Board took actions in 1992-1993 to specifically address issues related to direct haul and import of special wastes. These parameters were used to develop new conditions (conditions 8.5-8.8), which were approved in 2015 as part of the prior permit review."<sup>5</sup> Staff also explains "the Board did allow a grace period of 18 months for those direct haul conditions to take effect following the September 22, 2015 hearing."<sup>6</sup>

However, *more than a year later*, the Staff Report's only indication of KCL's efforts to comply with the direct haul conditions is to say that "[s]taff expects the landfill operator to begin developing documentation and implementing the tasks necessary to comply with the new conditions by the time they take effect next Spring."<sup>7</sup> Essentially, it appears that KCL has done nothing thus far to even attempt to comply with the direct haul conditions in the year since their approval and with only 5 months left before they become effective. This is important because since 1992-1993 the Board (predecessors to the current members) had the wisdom to impose restrictions on direct haul activities to the landfill and for some uncertain reason it took approximately 22 years to get those restrictions incorporated into KCL's permit.<sup>8</sup> This is really distressing to my family, my friends and neighbors and me.

The apparent lack of effort on the part of KCL regarding compliance with Conditions 8.5-8.8 of KCL's LUP is concerning because the deadline for compliance is *March 22, 2017* and the next permit review, as recommended by staff<sup>9</sup>, will likely occur in October of 2017. At this rate it will take another year before the

---

<sup>5</sup> *Id.* at 16.

<sup>6</sup> *Id.*

<sup>7</sup> Agenda Report for Agenda Item D.6 for the meeting of the Board of Supervisors scheduled for November 1, 2016, p. 3.

<sup>8</sup> It is also not clear whether the direct haul parameters adopted by the Board in 1992-1993 were ever enforced by County staff or otherwise complied with by KCL.

<sup>9</sup> Staff Report, p. 2.

Board has a chance to address KCL's compliance with direct haul limitations and the 22 plus years of free flowing direct haul will be further compounded.

Notably, staff indicates that “[a]s a result of AB939 and associated revisions to the Public Resources Code (PRC), counties are burdened with the responsibility of maintaining at least a 15-year supply of disposal capacity for all of the waste generated throughout each county.”<sup>10</sup>

The timely enforcement and implementation of Conditions 8.5-8.8 of KCL's LUP has a direct impact on the disposal capacity of the landfill because the enforcement of said conditions will limit the directly hauled waste that can be accepted by the landfill to material that cannot be recovered at a transfer station. Effectively, said conditions will work to prevent the disposal of otherwise recoverable material thereby preserving the disposal capacity of the landfill.

I urge the Board to take proactive measures to ensure that KCL meets the compliance deadline of March 22, 2017. Perhaps the Board could order the immediate enforcement of penalties for each day that KCL is out of compliance beginning March 22, 2017. Alternatively, or in conjunction with said penalties, the Board could direct staff to provide daily enforcement of these conditions by stopping all direct haul at the gate until KCL is able to comply on its own. The bottom line is that further delay in the implementation of the Board's direct haul policies is unacceptable.

#### **MATERIAL RECOVERY**

With regard to material recovery operations, there are three conditions of approval that Keller Canyon Landfill was not in compliance with at the 2014 Permit Review. In 2014, staff reported that Keller Canyon was not in compliance with conditions 31.4, 31.5, and 31.6.<sup>11</sup> Today, staff states the compliance status of condition 31.5 as “In Process” and conditions 31.4 and 31.6 as “Further Review Required”<sup>12</sup>.

The fact that compliance with these three conditions continues in varied pending states is concerning because these conditions have been in place since the inception of the landfill yet somehow, over 20 years later, KCL has managed to avoid both complying with these conditions and being penalized for such failure. The Board cannot let the same thing happen to Conditions 8.5-8.8.

In any event, Condition 31.4 relates to the implementation of a Material Recovery Program for recovering recyclables from refuse loads brought directly to the landfill. Such a program, if finally implemented, would have the potential to extend the disposal capacity of the landfill so that expansion of the landfill or siting of a new landfill would not be needed for many years to come.

However, as a resident living nearby and using the roads by Keller Canyon Landfill, I have several concerns regarding the expansion of activities at the landfill. For one, I am concerned that allowing material recovery operations at the landfill would have significant environmental impacts. An on-site material recovery program would likely require the use of heavy equipment to process material loads and additional transport trucks to take

---

<sup>10</sup> Staff Report, p. 8.

<sup>11</sup> 2014 Permit Review, p. 11.

<sup>12</sup> Staff Report, Exhibit D, pp. 57-58.

the material to proper recovery facilities. These activities would increase air pollution, water pollution, and noise from the operation of heavy equipment and from the increase of traffic in and around Bailey Road. In addition, the increase in traffic, in and around Bailey Road, would potentially increase hazards, accidents, and accelerate the deterioration of streets near and around that area.

Interestingly, Conditions 8.5 - 8.8 would work to restrict the acceptance of directly hauled waste loads containing material that would be recoverable. It is, therefore, not clear whether an onsite material recovery operation would even be needed at the landfill if KCL were to comply with Conditions 8.5-8.8.

Whatever material recovery program is ultimately implemented at the landfill, if any, it is important that it be limited in scope so that it is consistent with the existing environmental impact review or that a new environmental review be performed to ensure that needed mitigation is imposed for the safety and wellbeing of the surrounding communities. With that in mind it is all the more important that staff update the Board on just how far along the review of the new plans and any related environmental review is.

#### **FURTHER REVIEW AND CONSIDERATION REQUIRED**

In closing, further review and consideration of these issues is needed in order to ensure that Keller Canyon Landfill's operations, which deeply impact local communities such as mine, are properly monitored for compliance with the conditions of approval to its land use permit. Otherwise, residents such as me will have to deal with the negative impacts from those activities when it is the responsibility of the County to address and resolve such issues.

I appreciate the opportunity to comment on this matter and look forward to the Board of Supervisors taking action to address these concerns.

Respectfully submitted,

A handwritten signature in black ink, appearing to read "Lisa Della Rocca". The signature is fluid and cursive, with a long horizontal stroke at the end.

Lisa Della Rocca





Contra  
Costa  
County

To: Board of Supervisors  
From: John Kopchik, Director, Conservation & Development Department  
Date: November 1, 2016

Subject: Cost Confirmation Hearing for Real Property Located at 425 Market Ave., North Richmond

---

**RECOMMENDATION(S):**

OPEN the hearing on the itemized costs of abatement of real property located at 425 Market Ave., Richmond, California, Contra Costa County (APN 409-261-009);

RECEIVE and CONSIDER the attached itemized report on the abatement costs and any objections thereto from the property owner or other persons with a legal interest in the property; and CLOSE the hearing.

DETERMINE the cost of all abatement work and all administrative costs to be \$21,616.58.

ORDER the itemized report confirmed and DIRECT that it be filed with the Clerk of the Board of Supervisors.

ORDER the costs to be specially assessed against the above-referenced property and AUTHORIZE the recordation of a Notice of Abatement Lien.

**FISCAL IMPACT:**

No net fiscal impact. The costs as determined above will be added to the tax roll as a special assessment on this property and will be collected at the same time and in the same manner as ordinary County taxes are collected.

---

APPROVE

OTHER

RECOMMENDATION OF CNTY ADMINISTRATOR

RECOMMENDATION OF BOARD  
COMMITTEE

---

Action of Board On: 11/01/2016  APPROVED AS RECOMMENDED  OTHER

Clerks Notes:

**VOTE OF SUPERVISORS**

I hereby certify that this is a true and correct copy of an action taken and entered on the minutes of the Board of Supervisors on the date shown.

ATTESTED: November 1, 2016

Contact: Jason Crapo, (925)  
674-7722

David J. Twa, County Administrator and Clerk of the Board of Supervisors

By: , Deputy

cc:

BACKGROUND:

Contra Costa County Ordinance Code Article 14-6.4 and California Government Code Section 25845 authorize the recovery of abatement costs in public nuisance cases, the recordation of a Notice of Abatement Lien and inclusion of abatement costs on the tax roll as a special assessment, upon approval of the Board of Supervisors.

The Notice and Order to Abate was posted on the above-referenced property for fire damaged structure whose premises contain excessive vegetation, rubbish and debris, and was served on the property owner and all persons known to be in possession of the property by certified mail on October 13, 2015.

The property owner did not file an appeal of the Notice and Order to Abate. The County Abatement Officer abated the nuisance on June 1, 2016.

The property owner was billed for the actual cost of the abatement and all administrative costs. The bill was sent by first-class mail to the property owner on June 3, 2016. The property owner did not pay the bill within 45 days of the date of mailing.

Notice of this Cost Hearing was sent to the property owner by certified mail by the Clerk of the Board. For proof of service, see Clerk of the Board at 651 Pine Street, Room 106, Martinez, CA.

CONSEQUENCE OF NEGATIVE ACTION:

If not approved, the County will not be able to recover costs for abatement on code violations for this property.

CLERK'S ADDENDUM

***CLOSED the hearing; DETERMINED the cost of all abatement work and all administrative costs to be \$21,616.58; ORDERED the itemized report confirmed and DIRECTED that it be filed with the Clerk of the Board of Supervisors; ORDERED the costs to be specially assessed against the property and AUTHORIZED the recordation of a Notice of Abatement Lien.***

ATTACHMENTS

- Itemized Abatement Costs
- Before and After Photos

Market Ave

**CONTRA COSTA COUNTY**

DATE: October 7, 2016

TO: Clerk of the Board

FROM: Department of Conservation & Development  
By: Robert Erickson, Building Inspector II

RE: Itemized Report of Abatement Costs

The following is an itemized report of the costs of abatement for the below described property pursuant to C.C.C. Ord. Code ' 14-6.428.

OWNER: Fred Urquhart II

POSSESSOR: N/A

MORTGAGE HOLDER: Bank of America  
Custom Recording Solutions  
2550 N. Redhill Ave.  
Santa Ana, CA., 92705

ABATEMENT ORDERED DATE: October 13, 2015

ABATEMENT COMPLETED DATE: June 1, 2016

SITE ADDRESS: 425 Market Ave., Richmond, CA., 94801-1643  
APN#:409-261-013

PROPERTY DESCRIPTION: Residential

AMOUNT OF ABATEMENT COSTS (CCC ORDINANCE CODE 14-6.428)

<b>ITEM</b>	<b>EXPLANATION</b>	<b>COST</b>
Notice to Comply (include first 2 inspections)		\$ 250.00
Site Visits (4 x \$100 @)		\$ 400.00
PIRT (Title Search)		\$ 150.00
Certified Letter & Regular Mailings		\$ 97.58
Photos		\$ 19.00
Contractor hired for abatement		\$ 20,300.00
Final Site Inspection to Confirm Compliance		200.00
Compliance Report and Board Hearing		\$ 200.00
<b>Total</b>		<b>\$ 21,616.58</b>

Abatement costs can be paid at or mailed to Department of Conservation and Development, Building Inspection Division, 30 Muir Rd., Martinez, CA 94553.

425 Market Ave.

Richmond, CA., 94801-1643

Before Photos







425 Market Ave.

Richmond, CA., 94801-1643

After Photos







Contra  
Costa  
County

To: Board of Supervisors  
From: Julia R. Bueren, Public Works Director/Chief Engineer  
Date: November 1, 2016

Subject: APPROVE the Contra Costa County Parklet Program Guide to govern the permitting of parklets as encroachments in County rights of way.

---

**RECOMMENDATION(S):**

1. APPROVE the “Contra Costa County Parklet Program Guide” (Parklet Guide), attached hereto, to govern the permitting of parklets as encroachments in County rights of way;
2. AUTHORIZE the Public Works Director, or designee, to make non-substantive amendments to the Parklet Guide, as deemed necessary in the future; and
3. AUTHORIZE the Public Works Director, or designee, to issue parklet permits in accordance with the Parklet Guide and other applicable County ordinances governing encroachments, and
4. DETERMINE that the activity is not subject to the California Environmental Quality Act (CEQA), pursuant to Article 5, Section 15061(b)(3) of the CEQA Guidelines.

**FISCAL IMPACT:**

The establishment of the Parklet Program will not have a fiscal impact

---

<input checked="" type="checkbox"/> APPROVE	<input type="checkbox"/> OTHER
<input checked="" type="checkbox"/> RECOMMENDATION OF CNTY ADMINISTRATOR	<input type="checkbox"/> RECOMMENDATION OF BOARD COMMITTEE

---

Action of Board On: **11/01/2016**  APPROVED AS RECOMMENDED  OTHER

Clerks Notes:

**VOTE OF SUPERVISORS**

AYE: John Gioia, District I Supervisor  
 Candace Andersen, District II Supervisor  
 Mary N. Piepho, District III Supervisor  
 Karen Mitchoff, District IV Supervisor  
 Federal D. Glover, District V Supervisor

I hereby certify that this is a true and correct copy of an action taken and entered on the minutes of the Board of Supervisors on the date shown.

ATTESTED: November 1, 2016

David J. Twa, County Administrator and Clerk of the Board of Supervisors

By: June McHuen, Deputy

Contact: Mary Halle, (925) 313-2327

### FISCAL IMPACT: (CONT'D)

on the General Fund. Applicants will pay an application fee to cover staff time associated with technical review of the plans and inspection of parklet installation. Applicants will make a deposit to cover parklet removal in the event that the parklet is not removed when the permit is terminated or expires.

### BACKGROUND:

A parklet is a small extension of a sidewalk, intended as a recreational area to provide a sense of community and maximize the use of public space for amenities, green space or informal gatherings. Parklets have become quite popular in urban settings such as San Francisco, New York City, and downtown Martinez. Parklets typically occupy an on-street parking space(s) and are open to all members of the public. Parklets may support local businesses with locations adjacent to restaurants or shopping. A parklet may simply provide a feature of interest by providing public art or landscaping.

The Parklet Guide is intended as a resource to guide applicants on the requirements of a parklet installed as an encroachment within the public right of way. The Parklet Guide provides information on the optimal site location, design layout, operation, and maintenance of a parklet in order to assure public safety and that the parklet will be an amenity for the community. The Parklet Guide identifies the process for removal of a parklet in the event that it is not in the best interest of the community. The guide also includes the Parklet Permit Application, list of required conditions, and the process to obtain a Parklet Permit.

Like any applicant for an encroachment permit, an applicant for a parklet permit will submit an application and pay the County's encroachment permit fee. If a parklet will have a roof or overhead cover, the applicant also will need to obtain a building permit from the Department of Conservation and Development.

If the parklet encroachment meets the County's encroachment standards, including those in the Parklet Guide, the Public Works Department will issue a parklet permit. A permittee must maintain a liability insurance policy of not less than \$1 million that names the County as an additional insured, and the permittee will be required to indemnify the County from liabilities arising from the design, construction, use, operation, and maintenance of the parklet. The permittee must deposit funds sufficient to pay the estimated costs of removing the parklet should the applicant fail to remove the parklet at the end of the permit term. If the applicant does not remove the parklet, the County may remove the parklet using funds deposited by the permittee. After the parklet is removed, the deposit, or what remains of the deposit after the County removes the parklet, will be returned to the permittee.

### CONSEQUENCE OF NEGATIVE ACTION:

Failure to adopt the Parklet Program Guide will mean that there will not be an established process to install or implement parklets within the public right of way. And, applicants in the unincorporated areas of Contra Costa will not have the opportunity to install parklets.

### ATTACHMENTS

Parklet Program Guide

# PARKLET PROGRAM GUIDELINES

## Creating Community Space: Converting Pavement to Parks

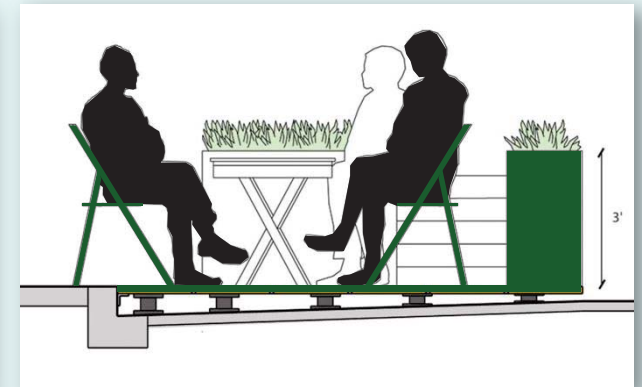

Graphics from National Association of City Transportation Officials



Contra Costa County  
Department of Conservation  
and Development



Contra Costa County  
**Public Works**  
Department

November 2016

# Creating Community Space



## TABLE OF CONTENTS

### INTRODUCTION

The Beginning

What Is a Parklet?

About This Manual

Program Goals

### PARKLET DESIGN STANDARDS

Parklet Location

Parklet Design

Additional Parklet Requirements

### PERMITTING PROCESS

Permitting Process Flow Chart

Application Content

Plans

Site Plan Example

Maintenance Agreement

Duration of Parklet Construction

Parklet Monitoring

Removal of Approved Parklet

### EXHIBITS AND RESOURCES

Application Package Checklist

Parklet Application

Operation, Maintenance, and Indemnification  
Agreement

Note: Photos taken by Mary Halle and Larry Leong, unless noted otherwise.

29

5

5

5

5

7

9

9

12

21

25

26

28

30

31

31

31

31

32

33

34

35

# Introduction



## **INTRODUCTION**

---

### **The Beginning**

In 2014, Contra Costa residents and community groups from the El Sobrante area recognized that there is a common desire to integrate recreational areas and community spaces within urban or commercial zones. A great deal of inspiration for these urban recreational areas was derived from the parklet programs that have been established in large cities such as San Francisco, Oakland, and New York City. These residents and community groups reached out to the Contra Costa Board of Supervisors and voiced their desire to assist with establishing a parklet program in the unincorporated areas of the County. As a result, the Board of Supervisors, Public Works Department staff, and Department of Conservation and Development staff collaborated with various stakeholders to develop the Contra Costa County Parklet Program which was adopted by the Board of Supervisors in 2016. With this program in place, there is now a resource and procedure available to aid

residents of the County in creating safe and aesthetically pleasing parklets in their community.

### **What Is a Parklet?**

Parklets are small sidewalk extensions intended to provide amenities, green space, or recreational areas to the public. They are usually constructed to encompass the area of a typical parking space(s), and are open to any member of the public. The purpose of community parklets is to maximize a sense of community by utilizing public spaces for aesthetic amenities to create features of interest or opportunities for informal gatherings.

### **About This Manual**

This manual is intended to provide a guide for residents, business owners or other interested parties who would like to establish a parklet in the unincorporated area of the County, as well as for County staff who will assist the parklet sponsor in the permitting process. This manual provides information on the standard design regulations and the steps required to obtain a parklet permit. The manual is intended to be a resource to all parties involved in the





Establishment of a parklet, regardless of whether the sponsor is early in the design stage, or having an existing parklet reviewed for renewal.

### **Program Goals**

Urban Green Space: As Contra Costa County continues to thrive, urban areas continue to emerge and grow to accommodate the needs of both residents and visitors. Parklets have great potential for providing green and/or recreational spaces in the heart of the County's vital urban areas, which can enhance aesthetic values and provide areas for community building.

Encourage Increased Pedestrian Activity: Parklets provide areas of interest along pedestrian corridors and places for pedestrians to rest and interact with others within the community.

Support for Local Business: Although parklets are open to the public and cannot be established solely for the benefit of an adjacent business, parklets tend to draw attention to adjacent establishments and provide areas that can be utilized by patrons.

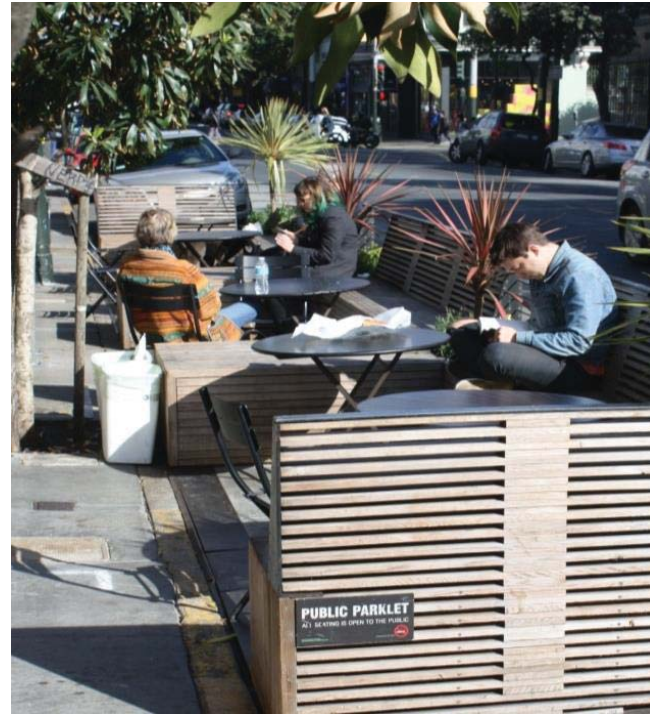

# Parklet Design Standards

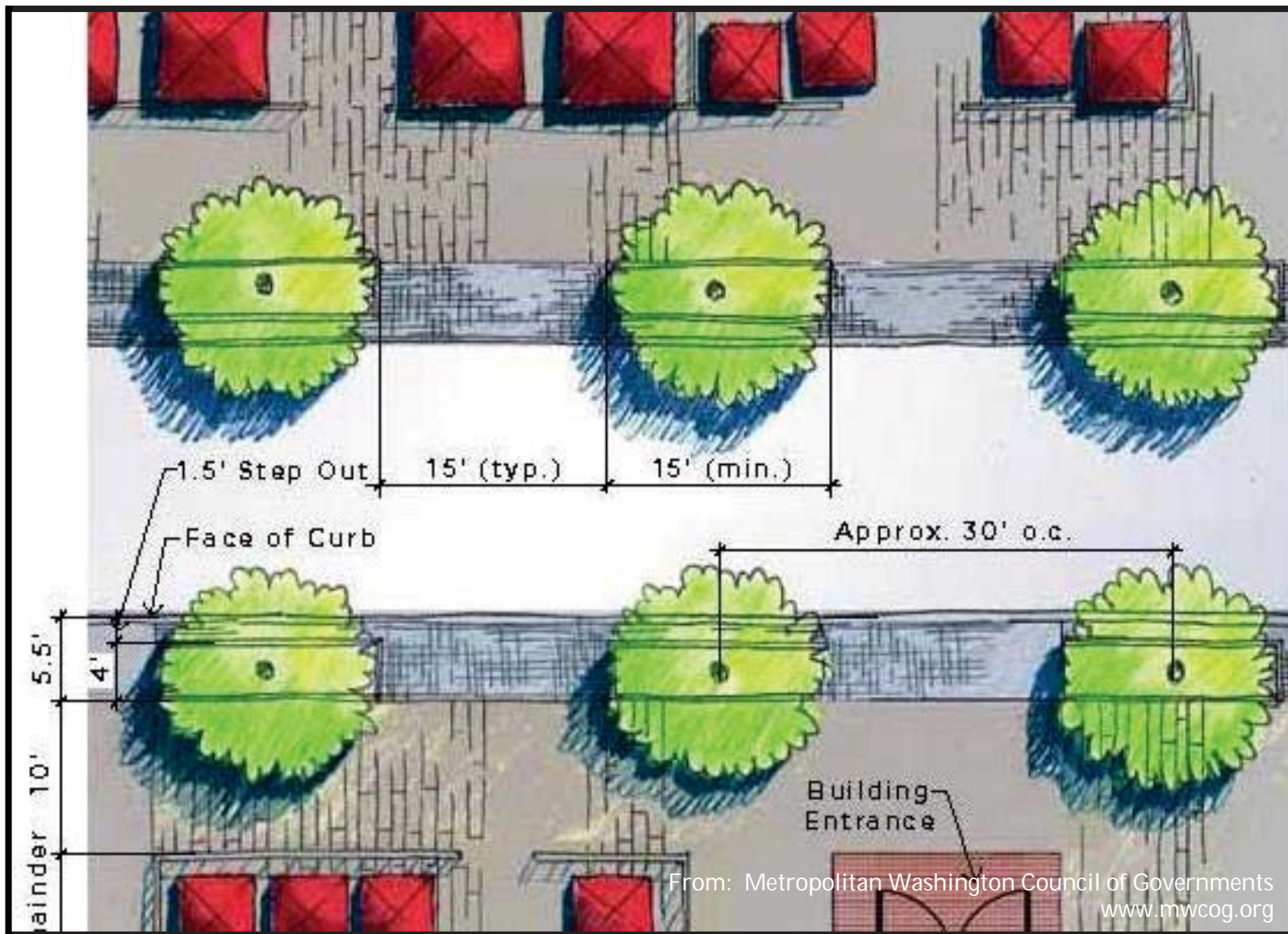

## PARKLET DESIGN STANDARDS

### Parklet Location

Identifying an appropriate location for a parklet is the key to successful implementation.

1. **Right-of-Way**: A parklet in the public right-of-way must be available for use by the general public. In addition, the location within the public right of way requires the applicant to obtain a permit to construct and operate in the public right of way. A parklet proposed within private roadways or on private property requires an alternate review and approval process.
2. **Designated On-Street Parking Areas**: A parklet shall only be located in designated on-street parking areas.
3. **Posted Speed Limit**: A parklet may be established along roadways where the posted speed limit is 25 mph or less. A parklet is allowed on streets where the posted speed is greater than 25 mph only if the Public Works Department determines that safety concerns have been addressed by the applicant.
4. **Traffic Volume and Collision History**: If a parklet is proposed on roadways with an Average Daily Traffic (ADT) count exceeding 10,000 vehicles, an additional deposit may be required as additional staff time may be required. Parklets proposed at locations with a significant collision history may also require additional review.
5. **Corner Location (see Figure 1)**: A parklet shall not block sight distance of motorists at intersections or driveways. Accordingly, a parklet may not be located less than 25 feet from a roadway intersection (see Figure 1 below and County Standard Plan CA10). The final distance required may vary based on the surrounding roadway conditions, and shall be subject to the approval of the Public Works Department.

Careful review of speed surveys, collision data, roadway geometrics, fortified railing design, sight distance, and other factors will be required at these locations. An additional deposit may be required for these locations as additional staff time will be required.

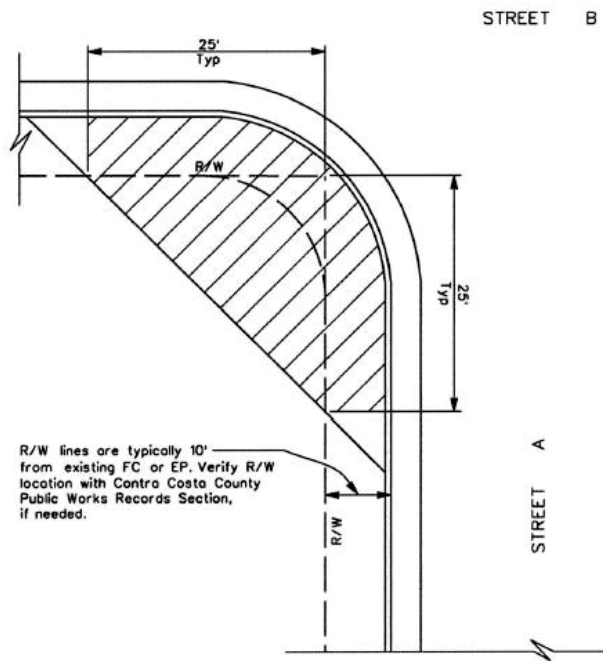

Figure 1: Sight Triangle at Corners (see CA10)

6. **Driveways (see Figure 2):** A parklet shall not be placed within 25 feet of an adjacent driveway or other points of off-street access which require line of sight standards as required by the Public Works Department. The final location of a parklet will vary based on the proposed parklet design, and shall be subject to review and approval.

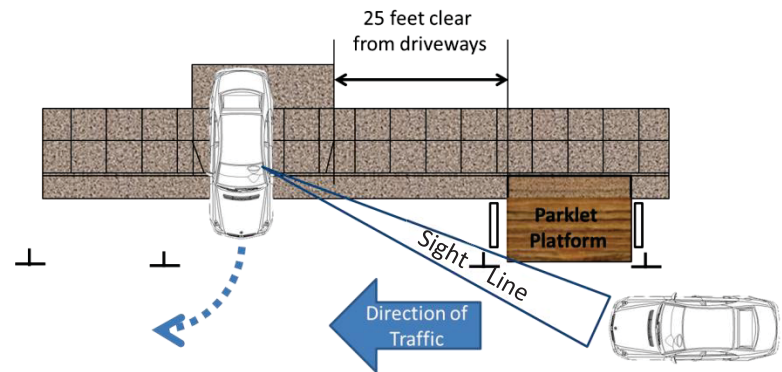

Figure 2: Driveway Clearance

7. **Longitudinal Slope:** Parklets are prohibited on streets where the longitudinal slope exceeds 5 percent (see Figure 3). When installed on a street with a longitudinal slope of three percent or greater, a parklet must include a wheelchair rest area.



Figure 3: Slope Diagram

8. **Parking Zones:** Parklets are prohibited in (disabled and no parking zones. Parklets may be permitted within loading, short-term and commercial loading/unloading zones on a case by case basis provided that the parklet will not create a safety hazard or adversely impact surrounding land uses.
9. **Utilities:** A parklet may not cover or impede access to any utility equipment, utility pole, fire hydrant, parking permit kiosk, or utility access such as manhole covers, drainage inlets, and equipment shelters. Additional setbacks from any of the above utility improvements and access points may be required to comply with the respective utility provider's standards.
10. **Public Transit (see Figure 4):** A parklet may not be located within a bus zone or impede access to a public transit stop (i.e. bus, light rail, or train, stop).

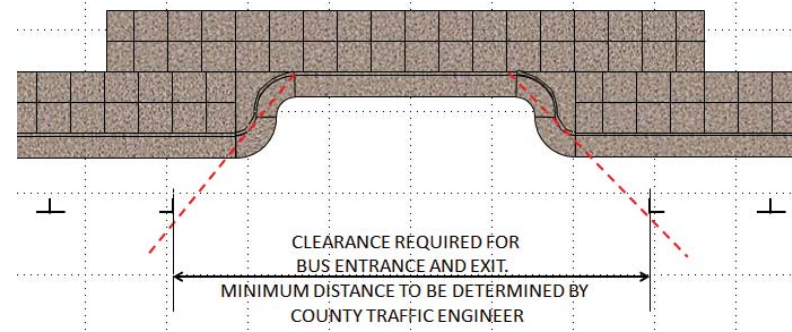

Figure 4 (Above): Parklet at Bus Turnout



## Parklet Design

A parklet design shall at minimum meet the following design standards.

1. **Parking Areas:** A parklet shall be located within designated on-street parking areas.

a. **Length in On-Street Parking Areas (Figure 5):**

When replacing on-street parking, a parklet shall be the length (dimension measured parallel to curb) of at least one (1) parking space or a minimum of 12 feet in unmarked parking areas.

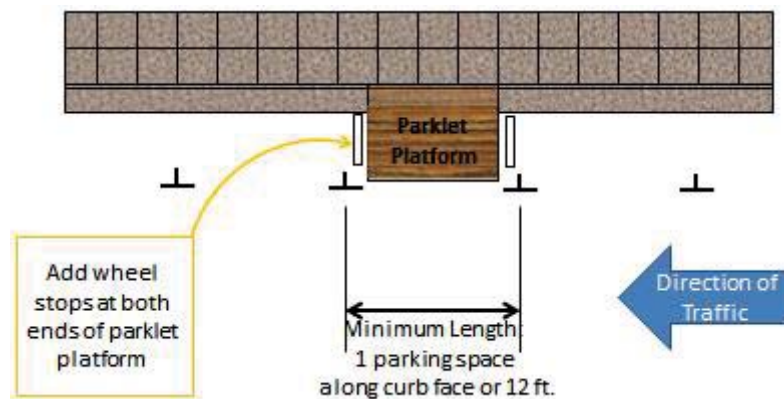

Figure 5: Parklet in Parallel Parking Spot

b. **Length in Diagonal Parking Areas (Figure 6):**

When replacing diagonal on-street parking, a parklet shall be the length of at least two (2) parking spaces.

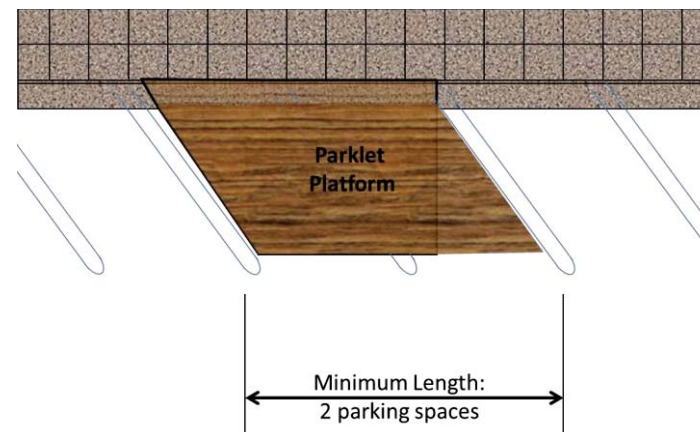

Figure 6: Parklet in Angled Parking Spots

c. **Length within Perpendicular Parking Areas (Figure 7):**

When replacing perpendicular on-street parking, a parklet shall be the length of at least two (2) parking spaces.

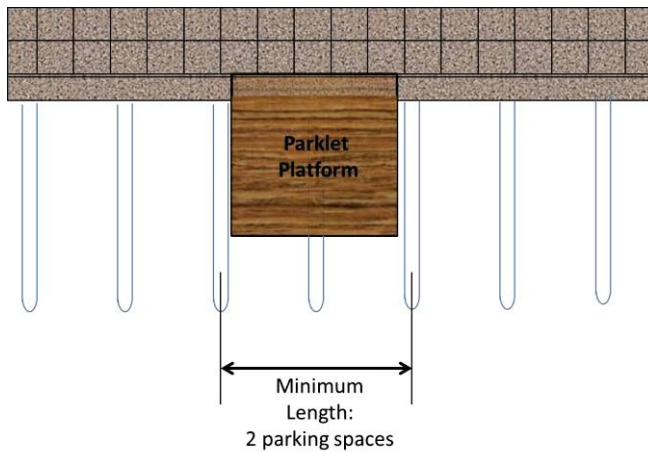

Figure 7: Parklet in Perpendicular Parking Spots

- d. **Optimized Parking Spaces** Parklet installation shall not leave an adjacent space that is too small to accommodate less than one full parking space.
- e. **Emergency Fire Access:** A parklet structure shall not exceed 32 feet in length (dimension measured parallel to the curb) unless a break or separation of at least four feet is provided to allow for emergency access from the traffic lane to sidewalk areas.

- f. **Parklet Depth (See Figure 8):** The depth (dimension measured perpendicular to curb) of a parklet shall be no less than the minimum dimension required to meet ADA accessibility requirements. Portions of the required parklet depth may be located within an existing sidewalk area as long as the sidewalk encroachment does not reduce the pedestrian path of travel to a width of less than 4.5 feet in the public right of way.

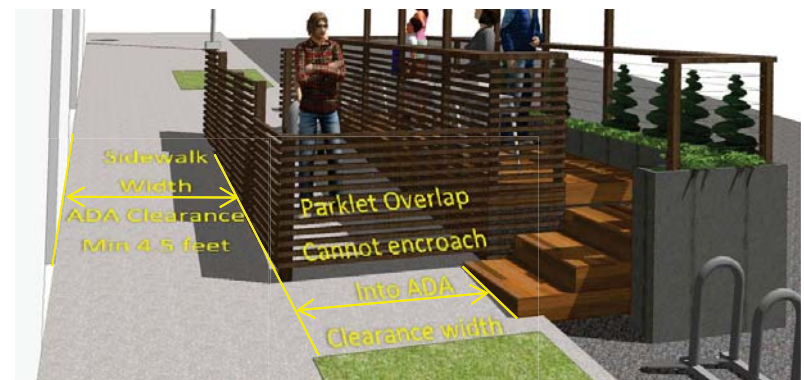

Figure 8: Parklet Depth and Sidewalk Clearance

- 2. **Fortified Railing (see Figure 9):** A parklet shall include an element of the parklet enclosure that addresses public safety and provides a barrier or fortified railing between moving vehicles and



parklet users. The design specifications of the barrier will depend on the design speed of the adjacent roadway, and must be approved by the Public Works Department.



Figure 9: Samples of Fortified Railing/Barrier

3. **Reflective Corner Elements (see Figure 10):** The four corners of a parklet shall have a reflective element or other clearly visible design feature, such as a soft-hit post, bollard, or raised pavement marker, to illuminate the parklet at night and signify the parklet envelope.



Figure 10: Sample Reflective Corner Elements

4. **Wheel Stops (see Figure 11):** In parallel parking areas, a 3-foot-long wheel stop shall be installed at each boundary between the parklet and the adjacent parking space. The wheel stop shall be installed so that it begins one foot away from the curb. A wheel stop shall be adequately secured to the roadway surface in a manner approved by the Public Works Department.



Figure 11: Sample Wheel Stop

5. **ADA Compliance:** A parklet shall comply with applicable Americans with Disabilities Act (ADA) accessibility standards. Compliance with ADA standards is required with respect to design elements of the parklet, as well as for adjacent areas that may be impacted by the parklet (e.g.

sidewalk areas). Loose materials such as sand, gravel, or loose stones are prohibited for use as a walking surface within a parklet.

6. **Wheelchair Accommodations:** A parklet shall have a minimum of one wheelchair resting area, one wheelchair turning space, and one companion seat. In a parklet where tables, counters, or drink rails are provided, at least one of the amenities shall be wheelchair accessible in terms of height and knee clearance. Figures 12–15 are samples from the 2010 ADA Standards that may apply to your parklet design.

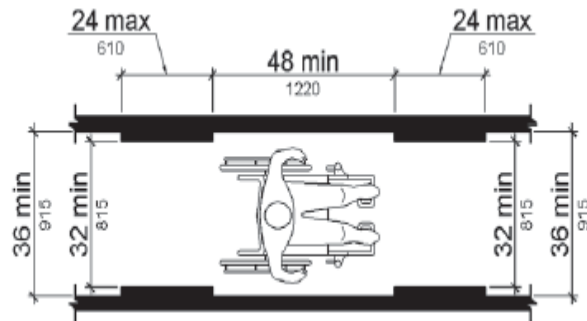

Figure 12: Clear Width of an Accessible Route (ADA 2010 Figure 403.5.1)

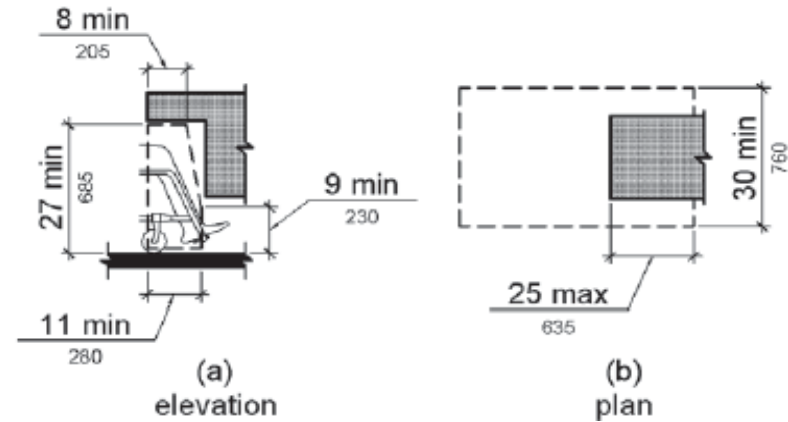

Figure 13: Knee Clearance (ADA 2010 Figure 306.3)

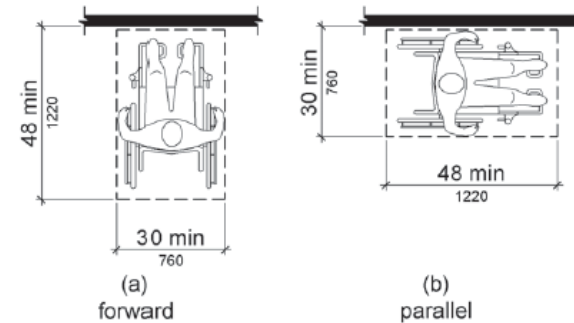

Figure 14: Position of Clear Floor or Ground Space (ADA 2010 Figure 3.5.5)

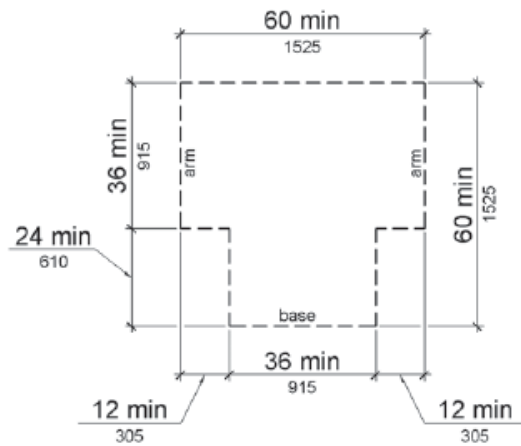

Figure 15: T-Shaped Turning Space  
(ADA 2010 Fig. 304.3.2)

7. **Building Permit Compliance:** A parklet shall be subject to and comply with the California Building Code.
8. **Platform Surface:** The top of a parklet platform shall be flush with the sidewalk grade. A cover, expansion joint, or other type of connector between the parklet surface and curb may also be required if necessary to provide a safe transition surface. If the platform base is not solid, the space underneath the platform surface must be accessible for maintenance through access panels, removable pavers, or other method.

To avoid a tripping hazard and achieve ADA compliance, a maximum elevation/height difference of  $\frac{1}{4}$  inch should be maintained between the curb and parklet platform.

A parklet platform shall be secured in place to prevent movement of the parklet structure. A parklet platform shall be secured to the existing street or curb by bolting or other method approved by the Public Works Department.

9. **Drainage (see Figure 16):** A parklet may not impede the flow of curbside drainage nor cover an existing drainage inlet. A parklet shall allow for conveyance of curbside drainage, in accordance with the Public Works Department's standards.

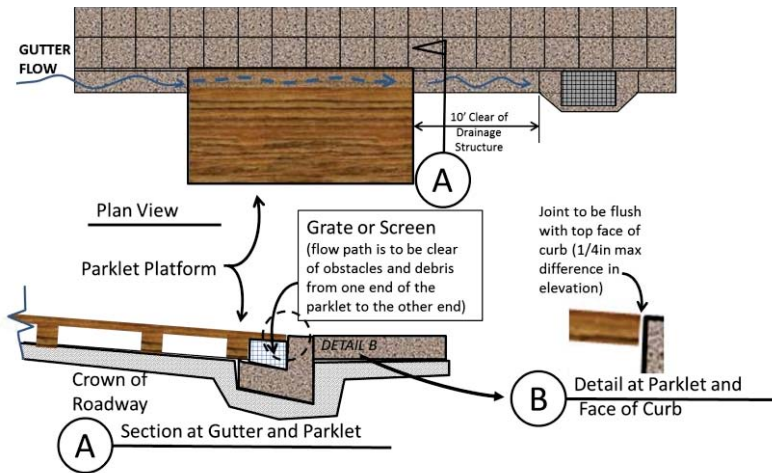

Figure 16: Parklet Drainage

10. **Cross Slope:** The cross slope (direction perpendicular to the street) of the parklet platform surface shall not exceed 2 percent.
11. **Buffer:** A parklet shall have an enclosure, structure, edge, or other buffer between parklet users and the adjacent traffic lane. This may take the form of planters, railings, cabling, or other appropriate buffer that is structurally fortified to meet the approval of the Public Works Department and DCD Building Inspection Division.
12. **Public Parklet Sign (see Figure 17):** A parklet shall have a minimum of two Public Parklet Signs

indicating the hours of operation, and that the parklet is to be publicly accessible at all times during posted parklet hours. A parklet shall be “closed” during the overnight hours. A Public Parklet Sign shall be at least 2 square feet in area. The location and design of the Public Parklet Signs shall be subject to review and approval by the County. No other signs, logos, or advertising are permitted within or on a parklet except for small plaques recognizing the parklet sponsor, material donors, and other contributors.



Figure 17: Sample Parklet Sign

13. **Traffic Lane (see Figure 18):** A parklet must be located so that the traffic lane adjacent to the parklet has a minimum of 15 feet in width. The required 15-foot lane is intended to provide a 12-foot-wide traffic lane and an additional buffer for

bicyclists as well as a general buffer for safety. No portion of a parklet structure shall protrude, cantilever, or otherwise encroach within the adjacent traffic lane or any delineated bike route.

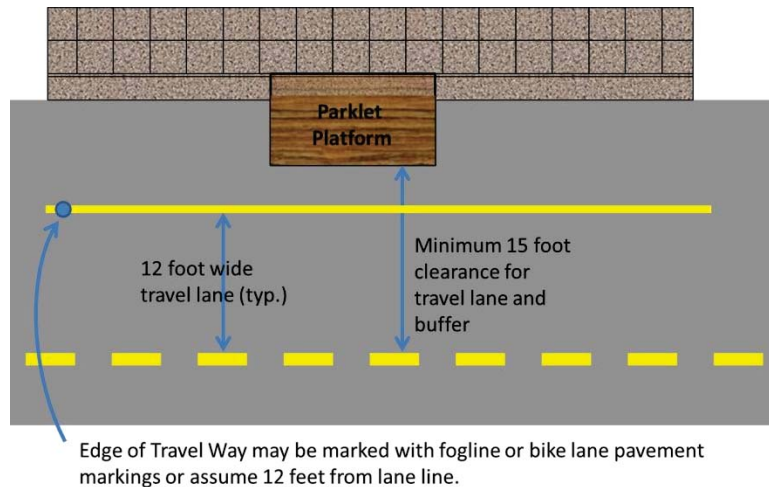

Figure 18: Parklet Clearance from Travel Lane

14. **Bike Route Accommodation**: The parklet site selection and design shall give consideration to avoid impacts to bike routes.
15. **Sidewalk Access**: A parklet may not reduce, encroach within, or otherwise block a designated

pedestrian path or sidewalk to a width of less than 4.5 feet.

16. **Points of Entry**: A parklet enclosure that includes a front (sidewalk side) wall shall have no less than two points of entry.
17. **Weight**: No parklet structure may weigh more than 200 pounds per square foot.
18. **Seating**: Some form of permanent seating is encouraged for incorporation in all parklet designs. Individual seating (e.g. chairs and stools) is preferred rather than bench seating as it discourages sleeping in the parklet. If permanent bench seating is used, the area below the bench shall be enclosed or otherwise made inaccessible to deter sleeping in that area.
19. **Trash Receptacle**: The parklet sponsor is responsible to furnish and service at least one permanent trash receptacle. Exceptions to this requirement may be allowed if a permanent trash receptacle is available on the sidewalk within 30 feet of the parklet.

20. **Height (see Figure 19):** A parklet's walls or railing shall not have a continuous height that exceeds 42 inches and shall not block views in or out of the parklet. Columns or other vertical framing for overhead elements are permitted.

However, a building permit must be obtained from the Building Inspection Division at DCD for any parklet enclosure that will include a roof, cover, or other type of overhead element. An overhead element shall maintain a minimum height of 84 inches between the parklet platform surface and the lowest point of the overhead element.

21. **Beautification Element (see Figure 20):** All parklet designs shall include a beautification element such as landscaping, artwork, or innovative architecture to improve the aesthetics of the parklet.

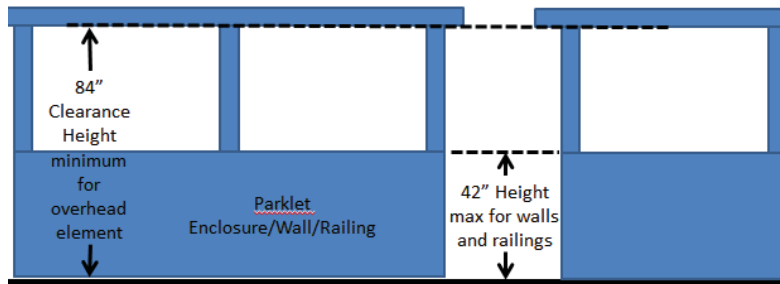

FRONT VIEW

Figure 19: Parklet Wall Height and Overhead Dimensions



Photo Source: Unknown

Figure 20: Sample Parklets with Beautification Elements

## Additional Parklet Requirements

1. **Authorization:** Prior to submitting an application for a parklet, the parklet sponsor shall obtain written authorization from the fronting property owner (in the event the applicant is not the owner of the fronting property), and written support from owners of the adjacent property owners.
2. **Building Permit:** In the event that the proposed parklet will include a roof, cover, or other type of overhead element, the parklet sponsor shall obtain a building permit from the Department of Conservation and Development, Building Inspection Division prior to constructing the parklet. A separate application and fee will be required for issuance of the building permit.
3. **Liability Insurance:** A parklet sponsor must maintain no less than \$1 million in liability insurance throughout the term of the parklet permit, in accordance with the Parklet Sponsor Operation, Maintenance, and Indemnification Obligations.

4. **Removal Deposit:** Prior to construction of a parklet and as a condition of parklet permit issuance, the parklet sponsor shall submit a cash deposit to the County in an amount the County determines is necessary to pay for the cost to remove the parklet and restore the right of way at the end of the parklet permit term. If the parklet sponsor abandons the parklet prior to the end of the parklet permit term, or refuses to remove the parklet upon request or termination of the parklet permit, the County will utilize the cash deposit to pay for the parklet removal costs.



Photo: Michael Macor, The Chronicle





**5. Operation, Maintenance, and Indemnification**

**Obligations:** The parklet sponsor must agree to the terms of the Parklet Sponsor Operation, Maintenance, and Indemnification Obligations provided under the Exhibits and Resources Section of this manual. Those obligations will be conditions of the parklet permit. If the parklet sponsor fails to comply with any of the obligations or any condition of approval of the parklet permit, the County may terminate the parklet permit and require the parklet to be removed.

a. **Parking Meters**: All parking meters located within the area in front of a proposed parklet shall be removed prior to use of the approved parklet. The cost for removal of parking meters shall be borne by the parklet sponsor, and supervised by staff of the Public Works Department.

b. **Amplified Sound**: No audio systems or other sound amplification devices are permitted for incorporation in the design of any parklet, and shall not be used on any parklet.

c. **Parklet Design Changes**: Proposed changes to elements of the parklet design such as color, materials, and size; shall require review by the County and Board-approved MAC, if applicable, prior to implementation.

d. **Smoking**: No smoking or vaping is permitted within a parklet at any time.

e. **Alcohol**: The consumption of alcohol is not permitted within a parklet at any time. This includes alcoholic beverages that may be available for purchase from an establishment located on the Fronting Property.

# Permitting Process



## PERMITTING PROCESS

---

### General Steps in the Permit Process:

1. Pre-application meeting – An Applicant should bring a site map of the location and a sketch of the conceptual design to a pre-application meeting with Public Works Department staff. This step is intended to provide initial feedback regarding site location and design to determine parklet feasibility. Nothing is submitted at this time but photos and sketches are helpful in discussion.
2. Initial Application submittal:
  - a. Site map showing all site constraints such as driveways, bus stops, utilities, sight line, existing on street parking opportunities and map of surrounding drainage patterns
  - b. Signed acceptance of concept by fronting and adjacent property owners
  - c. \$1,200 deposit
  - d. Acknowledgment that proof of \$1 million liability insurance and performance deposit will be due prior to permit issuance.
3. Initial Application review – Contra Costa Departments of Public Works and Conservation and Development (DCD) will review the initial application to determine whether the general location and concept are acceptable. If the County accepts the proposed location and concept, the applicant may prepare a full design submittal for the proposed parklet.
4. Full application submittal – In addition to items provided initial application, detailed design drawing should include: ADA compliance, railing or barrier design, beautification elements, drainage provisions, signage and description of operation. Payments should also be submitted including proof of insurance, performance deposit, and signed Parklet Sponsor Obligation form as well as proof of consultation with the local advisory group.

# Permitting Process Flow Chart

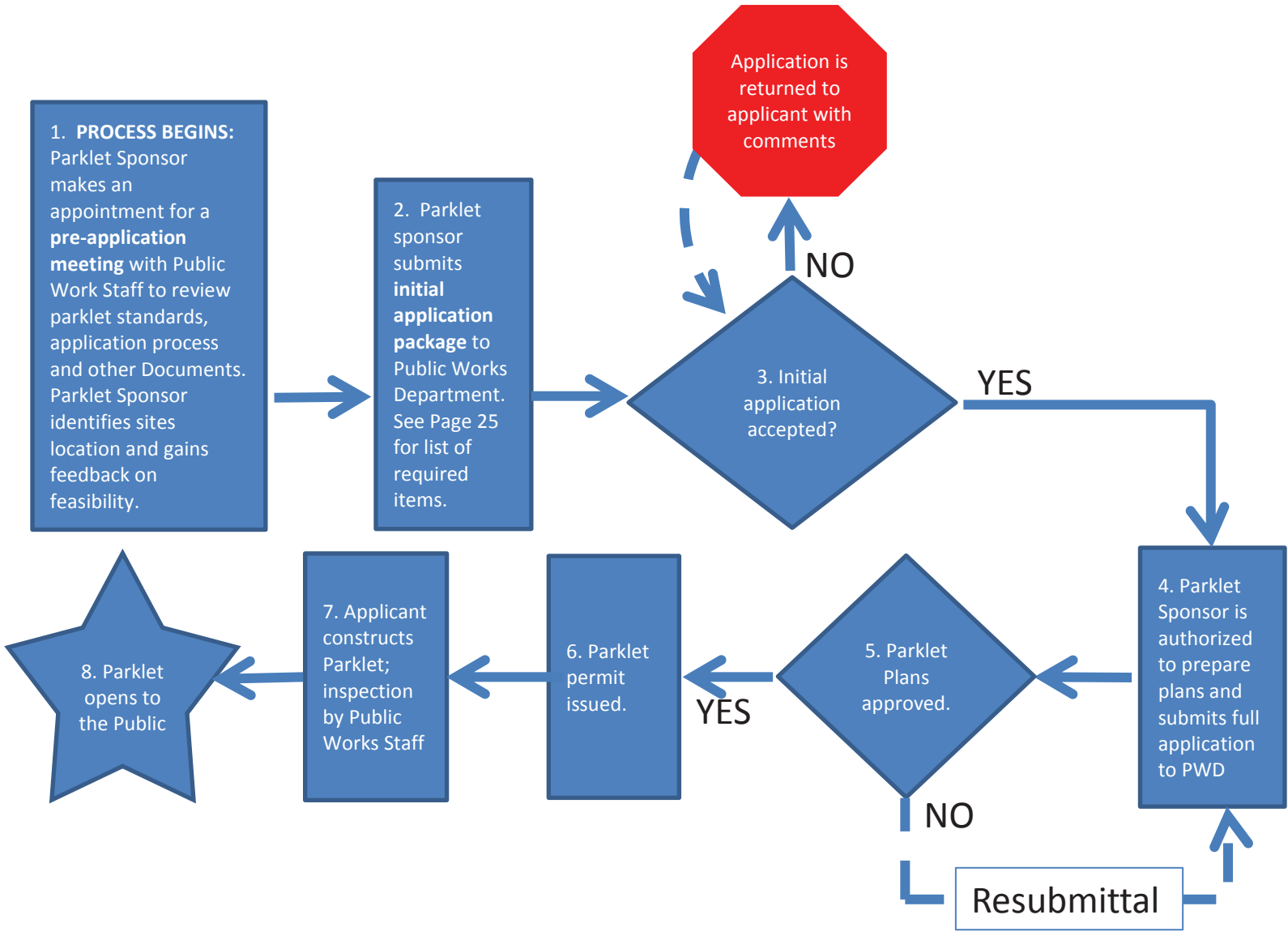

5. Detailed plan review – This step will require approximately eight weeks to complete. The parklet sponsor should allow time in their schedule; assuming plans will be reviewed and commented upon twice (four weeks to review each submittal) for a total review time of eight weeks.
6. Upon adequate resolution of all review comments and satisfaction of all conditions, insurance and deposits, a permit will be issued.
7. Applicant will construct the parklet with inspection by the Public Works Department. Parklet sponsor or their representative shall notify the Public Works Inspector for site visits as indicated in the conditions of the Parklet Permit.
8. Parklet is open to the public. The permit to operate the parklet will terminate two years following the opening of the parklet at which time the applicant may submit for renewal of

the parklet permit which will require a simple one page application to extend the term of the permit and a reduced deposit to cover the cost for staff review.

**Application Content:** Application For a parklet permit shall include the following:

- Completed and signed application
- Written authorization from adjacent business /property owners
- Parklet plans
- Photographs of existing site conditions
- Copy of Public Works Department drainage inventory map
- Drainage assessment of stormwater conveyance to verify that the parklet will not impede stormwater flow.
- Insurance certificate with County listed as additional insured with a \$1 million limit.
- Cash Performance Deposit in the amount the County determines is necessary to cover the cost of parklet removal and restoration of the right of way in the event that the parklet sponsor abandons the parklet and public funds must be used to restore the area.
- A cash deposit of \$1,200 to fund staff time to review and inspect parklet plans and site construction. If design is complex or site

conditions are not optimum, such that additional time will be required for review, the applicant must deposit additional funds to provide for the increased resources required.

- Proof of consultation with the local Municipal Advisory Council or similar community outreach in the area of the project.

**Plans:** All parklet plans shall include a site plan (see page 30), elevation view, cross section, and construction details

Submitted Plans shall at a minimum include the following:

- Name, type, and location of adjacent businesses
- Adjacent property lines
- Parklet location and dimensions
- Proposed parklet structure (enclosure) dimensions, materials, finishes
- Detailed plans of proposed fortified enclosure or other barrier, verifying it meets minimum safety standards for site conditions.
- Drainage assessment
- Required parklet setbacks or clearances.
- Existing parking spaces and striping with dimensions
- Adjacent auto, bike, and bus traffic lanes
- Location and type of adjacent colored curbs
- Sidewalk location and width within public right of way
- Curb cuts and driveways
- Existing parking meters

- Existing utilities on sidewalk and street (e.g. street lights, fire hydrants, man holes, power poles, etc.)
- Existing trees or other landscaped areas
- Location for required bollards and wheel stops
- Location of any existing utility easements
- Location and type of proposed landscaping and any required irrigation
- Sidewalk slope and parklet cross slope





# Site Plan Example

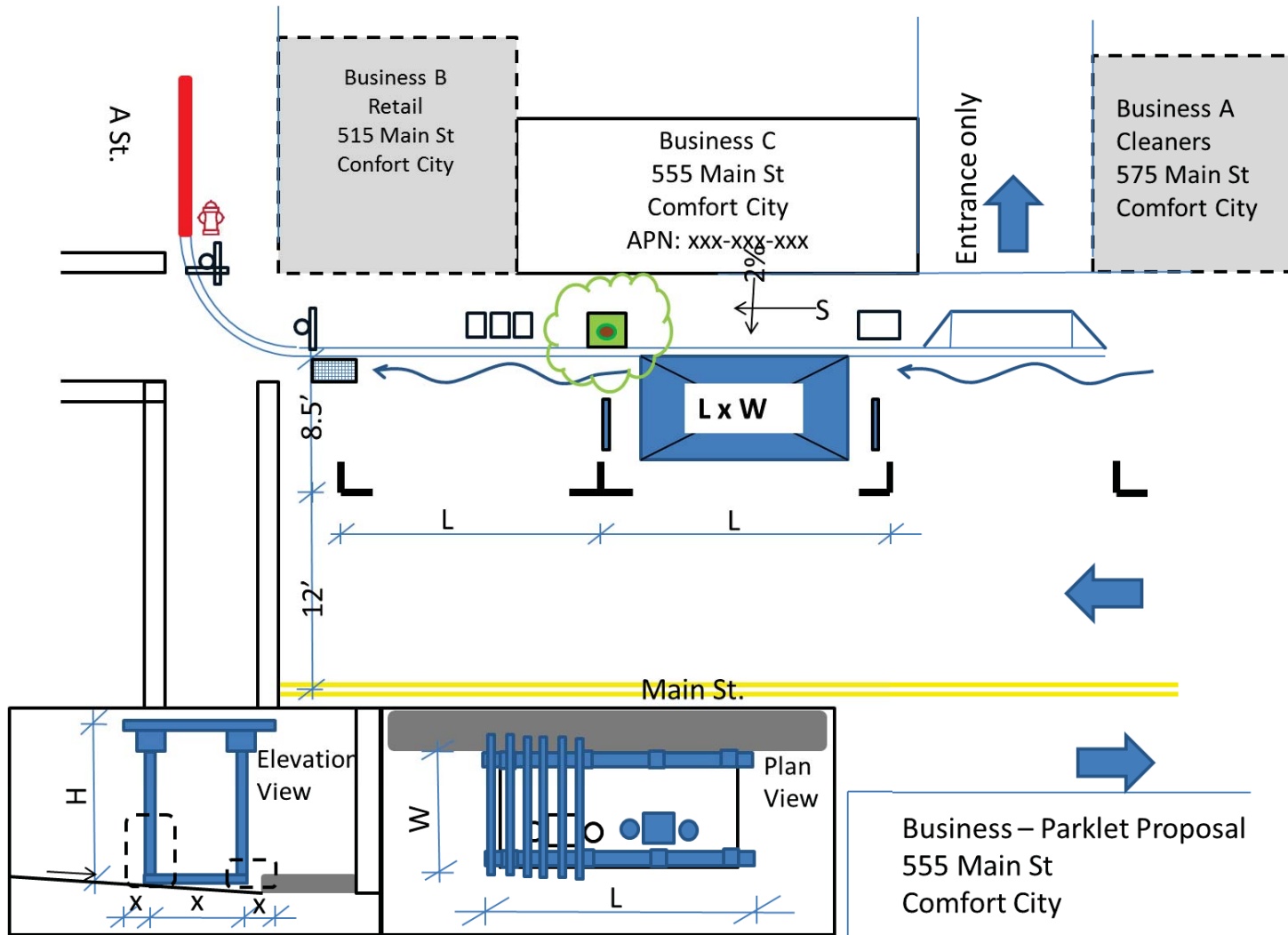

**Maintenance Agreement:** A parklet permit is a type of road encroachment permit which allows construction within the road right of way. Upon issuance of the parklet permit, the parklet sponsor must agree to the terms for maintenance of the parklet (see Appendix for sample Maintenance Agreement).

**Duration of Parklet Construction:** The applicant shall complete construction of the approved parklet within 3 months of the issuance date of the permit. If the Public Works Director finds there is a delay in completing the parklet construction or other lack of urgency by the applicant, the Director may terminate the permit and restore the right-of-way to its former condition.

**Parklet Monitoring:** Throughout the parklet use, all public comments, complaint calls, or other communications regarding the approved parklet shall be directed to the Public Works Department for documentation within the respective parklet encroachment permit file.

**Removal of Approved Parklet:** The Public Works Director may require removal of the parklet if the

applicant has failed to maintain the parklet or comply with any applicable conditions or if the parklet is causing a disturbance or public safety concern in the surrounding area. In this event, the applicant must remove the parklet and return the right of way to original condition or the performance deposit will be used to have the right of way restored.

# Exhibits and Resources



## APPLICATION PACKAGE SUBMITTAL CHECKLIST

1. **Application Form:** Please submit the completed and signed application.
  2. **Parklet Permit Deposit:** The applicant shall submit a deposit of \$1,200 to cover staff time for the review, coordination, and inspection of the parklet design and construction. Any unused portion of the deposit fund that remains at the conclusion of the permit process will be returned to the applicant. Similarly, additional payment may be required if the application review expenses exceed 100% of the initial deposit.
  3. **Site plan:** The applicant shall provide a detailed site plan that is drawn to scale and that shows the footprint of the proposed parklet installation. Please consult the “Parklet Plan Checklist” for a list of the required parklet site plan elements.
  4. **Photos of existing site:** Please submit photos of the location where you would like to install the parklet, including the parking spaces, the sidewalk, and building façade in front of the proposed location. Please consult the “Initial Specific Plan Checklist” for required photo perspectives.
  5. **Initial Concept Description:** A brief summary explaining your project goals and the vision for your parklet. Why have you chosen this location? What activities would you like to promote on the parklet? How do you anticipate the community will be involved in the creation and use of the new parklet?
  6. **Community feedback on Parklet Design:** Prior to permit approval, the applicant must submit the parklet application to the Board–appointed Municipal Advisory Council (MAC) for review and comment. If a MAC does not exist in the area of the project, please consult Public Works staff on whether outreach can be conducted with other community groups in the area.
  7. **Letter of Authorization** from fronting and adjacent property owner(s) (see description on Page 21)
-





# Contra Costa County Parklet Application

## PARKLET INFORMATION

Address of Proposed Parklet: \_\_\_\_\_ Zip: \_\_\_\_\_

Cross Street: \_\_\_\_\_

## PARKLET INFORMATION

Applicant /Organization: \_\_\_\_\_

Mailing Address: \_\_\_\_\_ Zip: \_\_\_\_\_

Contact Name: \_\_\_\_\_ Signature: \_\_\_\_\_

Phone 1: \_\_\_\_\_ Date: \_\_\_\_\_

## FRONTING PROPERTY INFORMATION/AUTHORIZATION

Fronting Property Address: \_\_\_\_\_ Zip: \_\_\_\_\_

Name(s) of Property Owner: \_\_\_\_\_ Signature: \_\_\_\_\_

Name(s) of Property Owner: \_\_\_\_\_ Signature: \_\_\_\_\_

Property Owner Mailing Address: \_\_\_\_\_ Zip: \_\_\_\_\_

Phone: \_\_\_\_\_ Date: \_\_\_\_\_

## ADJACENT PROPERTY OWNER INFORMATION/AUTHORIZATION

Adjacent Property Address: \_\_\_\_\_

Adjacent Property Owner: \_\_\_\_\_ Signature: \_\_\_\_\_

Adjacent Property Owner Mailing Address: \_\_\_\_\_

Phone: \_\_\_\_\_ Date: \_\_\_\_\_

## ADJACENT PROPERTY OWNER INFORMATION/AUTHORIZATION

Adjacent Property Address: \_\_\_\_\_

Adjacent Property Owner: \_\_\_\_\_ Signature: \_\_\_\_\_

Adjacent Property Owner Mailing Address: \_\_\_\_\_

Phone: \_\_\_\_\_ Date: \_\_\_\_\_



# PARKLET SPONSOR OBLIGATIONS

## OPERATION, MAINTENANCE, AND INDEMNIFICATION

### 1. PARKLETS MUST BE OPEN TO THE PUBLIC

The parklet sponsor shall keep the parklet free and open to all members of the public, regardless of whether or not they patronize any particular business. The parklet sponsor shall ensure that table service from any adjacent business establishment is not provided within the parklet, and condiments, napkins, or other items distinctly associated with an adjacent business are not placed on the parklet tables. However, if tables are placed in the parklet, the parklet sponsor shall be responsible for clearing and cleaning each table after each use, to ensure it remains clean and well maintained.

### 2. INDEMNIFICATION

(a) The County is under no obligation to maintain or repair the parklet, and these obligations shall not be construed to impose any such obligation on the County.

(b) To the maximum extent permitted by law, the parklet sponsor shall defend, indemnify, save, and hold harmless the County, its governing board, officers, agents, and employees (“indemnitees”) from any and all demands, losses, claims, costs, suits, liabilities, and expenses for any property damage, personal injury, or death arising directly or indirectly from or connected with the design construction, use, operation, or maintenance of the parklet by the parklet sponsor or the presence or existence of the parklet, except for claims, costs, or liabilities resulting from the sole negligence or sole willful misconduct of the County. If any action or proceeding is brought against any of the indemnitees, the parklet sponsor shall reimburse the indemnitees for any expenditures, including reasonable attorney’s fees and costs, incurred by the indemnitees, and if requested by any of the indemnitees, shall defend the action or proceeding at the parklet sponsor’s sole expense with counsel acceptable to the indemnitees.

### 3. UPKEEP, MAINTENANCE, & REPAIR

(a) The parklet sponsor shall keep the parklet well maintained and in good condition. The parklet sponsor shall ensure that the parklet is swept at least once per week, kept free of debris, dirt, and graffiti, and that any plants within the parklet are maintained in good health.

(b) The parklet sponsor shall keep the sidewalk area adjacent to the parklet clean and well maintained in an effort to eliminate tripping and slipping hazards, such as cracked or uneven sidewalk. The parklet sponsor shall be solely responsible for paying all costs to repair and maintain the portion of the sidewalk adjacent to the parklet.

---



(c) The parklet sponsor shall be responsible for removing, as frequently as necessary, any trash that collects within the parklet to maintain a trash-free parklet. The parklet sponsor shall also be responsible for removing any trash that collects within the public right-of-way within 25 feet of the parklet.

(d) If an errant motorist, vandalism, an act of any third party, an act of nature, or negligent maintenance by the parklet sponsor causes damage to the parklet, the parklet sponsor shall report the damage to the County and indicate the intended efforts to remedy the cause and either repair the parklet to the extent necessary to return the parklet to its initially approved design and condition, make modifications to the parklet to deter future damage, or to remove the parklet.

(e) Leaves and debris may collect beneath the parklet which can cause ponding of water or clogging of gutters. These conditions can cause odors or become a refuge for rodents and insects. The parklet sponsor shall be aware of these tendencies and take action to prevent odors or nuisance from rodents or insects to occur.

#### **4. LIABILITY INSURANCE**

At all times during the term of the parklet permit, the parklet sponsor shall maintain no less than \$1 million in liability insurance coverage under a policy that names the County and its officers and employees as additional insureds. No later than five days after the parklet sponsor's receipt of a notice of cancellation, notice of intention to cancel, notice of lapse of insurance coverage, or notice of material change to the insurance coverage, the parklet sponsor shall provide the County a copy of that notice. If the sponsor fails to provide the County a copy of the notice as required under the preceding sentence, or fails to maintain the insurance coverage required by this paragraph, then, at County's sole discretion, the County may revoke the parklet permit and order the removal of the parklet.

#### **5. NO PROPERTY INTEREST**

The parklet permit issued by the County to the parklet sponsor does not convey, nor shall it be construed as conveying, any property interest to the parklet sponsor. The parklet sponsor shall not assert against the County or any other person any claim of property interest to or within the County right-of-way based on its possession of a parklet permit, or based on the occupancy of the County right-of-way by its parklet.

#### **6. TERMINATION OF PARKLET PERMIT**

(a) If the parklet sponsor fails to meet any of the obligations contained herein, or any term or condition of approval of the parklet permit, the County, at its sole discretion, may terminate that permit.

---

(b) Upon the expiration or termination of a parklet permit, the parklet sponsor shall remove the parklet from the County right-of-way and return the surface of the right-of-way to the condition it was in before the parklet was installed.

(c) If the parklet sponsor fails or refuses to remove the parklet within 30 days after the parklet permit terminates or expires, the County, at its sole discretion, may draw upon or claim against the removal deposit or other security provided by the parklet sponsor as a condition of parklet permit approval; and the County may use those funds to pay the cost of removing the parklet from the County right-of-way.

Parklet Sponsor Signature: \_\_\_\_\_

Date: \_\_\_\_\_

Parklet Sponsor Name: \_\_\_\_\_

Parklet Address: \_\_\_\_\_

Encroachment Permit #: \_\_\_\_\_

---









Contra  
Costa  
County

To: Board of Supervisors  
From: Julia R. Bueren, Public Works Director/Chief Engineer  
Date: November 1, 2016

Subject: Fully close the northbound lanes of Danville Boulevard between Orchard Lane and Jackson Way on December 4, 2016, Alamo area.

---

**RECOMMENDATION(S):**

ADOPT Resolution No. 2016/601 approving and authorizing the Public Works Director, or designee, to fully close the north bound lanes of Danville Boulevard between Orchard Lane and Jackson Way, and to fully close Jackson Way at the intersection with Danville Boulevard, on December 4, 2016 from 4:30 p.m. to 6:30 p.m., for the purpose of the Annual Alamo Tree Lighting Event, Alamo area. (District II)

**FISCAL IMPACT:**

No fiscal impact.

**BACKGROUND:**

Applicant shall follow guidelines set forth by the Public Works Department.

**CONSEQUENCE OF NEGATIVE ACTION:**

Applicant will be unable to close the road for planned activities.

---

APPROVE  OTHER  
 RECOMMENDATION OF CNTY ADMINISTRATOR  RECOMMENDATION OF BOARD COMMITTEE

---

Action of Board On: **11/01/2016**  APPROVED AS RECOMMENDED  OTHER

Clerks Notes:

**VOTE OF SUPERVISORS**

AYE: John Gioia, District I Supervisor  
Candace Andersen, District II Supervisor  
Mary N. Piepho, District III Supervisor  
Karen Mitchoff, District IV Supervisor  
Federal D. Glover, District V Supervisor

I hereby certify that this is a true and correct copy of an action taken and entered on the minutes of the Board of Supervisors on the date shown.

ATTESTED: November 1, 2016

David J. Twa, County Administrator and Clerk of the Board of Supervisors

By: Stacey M. Boyd, Deputy

Contact: Bob Hendry, (925) 674-7744

cc:

AGENDA ATTACHMENTS

Resolution No. 2016/601

MINUTES ATTACHMENTS

Signed: Resolution No.

2016/601

**THE BOARD OF SUPERVISORS OF CONTRA COSTA COUNTY, CALIFORNIA**  
**and for Special Districts, Agencies and Authorities Governed by the Board**

Adopted this Resolution on 11/01/2016 by the following vote:

		<b>John Gioia</b>
		<b>Candace Andersen</b>
<b>AYE:</b>	<input type="text" value="5"/>	<b>Mary N. Piepho</b>
		<b>Karen Mitchoff</b>
		<b>Federal D. Glover</b>
<b>NO:</b>	<input type="text"/>	
<b>ABSENT:</b>	<input type="text"/>	
<b>ABSTAIN:</b>	<input type="text"/>	
<b>RECUSE:</b>	<input type="text"/>	



**Resolution No. 2016/601**

IN THE MATTER OF approving and authorizing the Public Works Director, or designee, to fully close the north bound lanes of Danville Boulevard between Orchard Lane and Jackson Way, and to fully close Jackson Way at the intersection with Danville Boulevard, on December 4, 2016 from 4:30 p.m. to 6:30 p.m., for the purpose of the Annual Alamo Tree Lighting Event, Alamo area. (District II)

RC16-11

NOW, THEREFORE, BE IT RESOLVED that permission is granted to the Community Foundation of Alamo to fully close the north bound lanes of Danville Boulevard between Orchard Lane and Jackson Way, and to fully close Jackson Way at the intersection with Danville Boulevard, except for emergency traffic, on December 4, 2016 for the period of 4:30 p.m. to 6:30 p.m., subject to the following conditions:

1. Traffic will be detoured via per traffic control plan reviewed by Public Works.
2. All signing to be in accordance with the California Manual on Uniform Traffic Control Devices.
3. Community Foundation of Alamo shall comply with the requirements of the Ordinance Code of Contra Costa County.
4. Provide the County with a Certificate of Insurance in the amount of \$1,000,000, for Comprehensive General Public Liability which names the County as an additional insured prior to permit issuance.
5. Obtain approval for the closure from the Sheriff's Department, the California Highway Patrol and the Fire District.

I hereby certify that this is a true and correct copy of an action taken and entered on the minutes of the Board of Supervisors on the date shown.

**Contact: Bob Hendry, (925) 674-7744**

**ATTESTED: November 1, 2016**

David J. Twa, County Administrator and Clerk of the Board of Supervisors

By: Stacey M. Boyd, Deputy

**cc:**



**THE BOARD OF SUPERVISORS OF CONTRA COSTA COUNTY, CALIFORNIA**

**and for Special Districts, Agencies and Authorities Governed by the Board**

Adopted this Resolution on 11/01/2016 by the following vote:

**John Gioia**  
**Candace Andersen**  
**Mary N. Piepho**  
**Karen Mitchoff**  
**Federal D. Glover**

AYE:  5

NO:

ABSENT:

ABSTAIN:

RECUSE:



**Resolution No. 2016/601**

IN THE MATTER OF approving and authorizing the Public Works Director, or designee, to fully close the north bound lanes of Danville Boulevard between Orchard Lane and Jackson Way, and to fully close Jackson Way at the intersection with Danville Boulevard, on December 4, 2016 from 4:30 p.m. to 6:30 p.m., for the purpose of the Annual Alamo Tree Lighting Event, Alamo area. (District II)

RC16-11

NOW, THEREFORE, BE IT RESOLVED that permission is granted to the Community Foundation of Alamo to fully close the north bound lanes of Danville Boulevard between Orchard Lane and Jackson Way, and to fully close Jackson Way at the intersection with Danville Boulevard, except for emergency traffic, on December 4, 2016 for the period of 4:30 p.m. to 6:30 p.m., subject to the following conditions:

1. Traffic will be detoured via per traffic control plan reviewed by Public Works.
2. All signing to be in accordance with the California Manual on Uniform Traffic Control Devices.
3. Community Foundation of Alamo shall comply with the requirements of the Ordinance Code of Contra Costa County.
4. Provide the County with a Certificate of Insurance in the amount of \$1,000,000, for Comprehensive General Public Liability which names the County as an additional insured prior to permit issuance.
5. Obtain approval for the closure from the Sheriff's Department, the California Highway Patrol and the Fire District.

I hereby certify that this is a true and correct copy of an action taken and entered on the minutes of the Board of Supervisors on the date shown.

**ATTESTED: November 1, 2016**

David J. Twa, County Administrator and Clerk of the Board of Supervisors

By: Stacey M. Boyd, Deputy

Contact: Bob Hendry, (925) 674-7744

cc:



Contra  
Costa  
County

To: Board of Supervisors  
From: Julia R. Bueren, Public Works Director/Chief Engineer  
Date: November 1, 2016

Subject: Approve and Authorize the Auditor-Controller to issue a payment of \$1,500 to the Community Foundation of Alamo for the holiday lights, Alamo area.

**RECOMMENDATION(S):**

APPROVE and AUTHORIZE the Auditor-Controller, or designee, to issue a payment on behalf of the Public Works Director, in the amount of \$1,500, from County Service Area R-7A (CSA R-7A) payable to the Community Foundation of Alamo for the holiday lights at Andrew H. Young Park, Alamo Area. (District II)

**FISCAL IMPACT:**

100% CSA R-7A funds.

**BACKGROUND:**

CSA R-7A participates in Alamo's Annual Tree Lighting Festival each year. The Community Foundation of Alamo is the sponsor of the 2016 event. CSA R-7A contributes the use of Andrew H. Young Park and provides funding to decorate the park with holiday lights. The event will take place on Sunday, December 4, 2016, from 4:30 p.m. to 6:30 p.m. The lights will be installed on or after November 15, 2016, and will remain up through the first week of January 2017. The Alamo Tree Lighting event is a collaborative effort coordinated by the Community Foundation of Alamo. The event was reviewed by the Alamo Municipal Advisory Council on May 3, 2016 when planning for the 2016-17 recreation budget of \$1,500 was recommended for this event.

APPROVE

OTHER

RECOMMENDATION OF CNTY  
ADMINISTRATOR

RECOMMENDATION OF BOARD  
COMMITTEE

Action of Board On: **11/01/2016**  APPROVED AS  
RECOMMENDED

OTHER

Clerks Notes:

**VOTE OF SUPERVISORS**

AYE: John Gioia, District I Supervisor  
Candace Andersen, District II  
Supervisor  
Mary N. Piepho, District III Supervisor  
Karen Mitchoff, District IV Supervisor  
Federal D. Glover, District V Supervisor

I hereby certify that this is a true and correct copy of an action taken and entered on the minutes of the Board of Supervisors on the date shown.

ATTESTED: November 1, 2016

David J. Twa, County Administrator and Clerk of the Board of Supervisors

Contact: Victoria Skerritt, (925)  
313-2272

By: Stacey M. Boyd, Deputy

CONSEQUENCE OF NEGATIVE ACTION:

Without Board approval this event would not be possible.

ATTACHMENTS

Alamo MAC Meeting Record of Actions for May 3, 2016, 2016/17

CSA R-7 BUDGET with detail of CSA R-7A approved 2016/17 Event  
Expenditures

# Alamo Municipal Advisory Council

Anne Struthers, Chair  
Susan Rock, Vice-Chair  
David Barclay  
Ed Best  
Aron DeFerrari, Alternate  
Rachel Etherington, Youth Member  
Michael McDonald  
Steve Mick  
Jill Winspear



**Candace Andersen, Supervisor**

Contra Costa County, District 2  
309 Diablo Road  
Danville, CA 94526  
925-957-8860

[jen.quallick@bos.cccounty.us](mailto:jen.quallick@bos.cccounty.us)

*The Alamo Municipal Advisory Council serves as an advisory body to the Contra Costa County Board of Supervisors and the County Planning Agency.*

## Record of Actions

**Tuesday, May 3, 2016 6:00 p.m.**

**Alamo Women's Club - 1401 Danville Boulevard, Alamo**

*Time is allotted under Public Comment for persons who wish to speak for up to three minutes on any item NOT on the agenda. Persons who wish to speak on matters on the agenda will be heard for up to three minutes when the Chair calls for comments. After persons have spoken on an agenda item, the public comment period will be closed by the Chair and the matter is subject to discussion and/or action by the MAC. Persons wishing to speak must fill out a speaker card.*

### **1. CALL TO ORDER - PLEDGE OF ALLEGIANCE - ROLL CALL**

The meeting was called to order at 6:00 p.m.

Alamo Municipal Advisory Council members present: Susan Rock, David Barclay, Ed Best, Aron DeFerrari, Rachel Etherington, Michael McDonald and Steve Mick Absent: Anne Struthers

### **2. STAFF/AGENCY REPORTS**

A. District II Staff Update - The next Alamo Liaison meeting is scheduled for May 16, 2016, beginning at 8:30 a.m.  
Location: Supervisor Andersen's Office 309 Diablo Road, Danville.

B. San Ramon Valley Fire Protection District, Chief, Paige Meyer, and Deputy Chief, Derek Krause.

- Station 32 construction is progressing nicely with vertical construction has started.
- The District has declared that all dry grasses, weeds, dead trees and/or rubbish in a wildfire hazard severity zone is a fire hazard and abatement of the hazard must be completed by May 31<sup>st</sup>. Property inspections will begin June 1, 2016.

### **3. PUBLIC COMMENT (3 minutes/speaker)**

*Pursuant to the Brown Act, this time is provided for members of the public and community groups to address the committee on matters within the committee's jurisdiction and not on the agenda. An opportunity will be provided as part of each agenda item for public comment on the item. Time allowed for each individual is three minutes. The Chair will recognize only those speakers who have filled out and turned in a speaker card.*

### **4. PRESENTATIONS**

A. None.

### **5. NEW BUSINESS**

A. Variance application #VR16-1014 - The applicant requests approval of a variance to allow for a 1,587 square foot detached garage with a 275 square foot wine cellar (where 600 square feet is the maximum). Property is located at 70 Holiday. – *UPDATE – application has been withdrawn per Department of Conservation and Development. After further research by planning staff a records search on this property turned up a finalized building permit from 1979 for a detached garage for the same size and square footage as the garage today that the homeowner is looking to renovate. Since the building was permitted with a final building inspection, then there is no need for the requested variance. You can renovate (interior work) on a permitted building.*

**Public Comment:**  
**Mike Gibson, representing AIA**

**No Action taken as project application was withdrawn per the Department of Conservation and Development.**

- B. Variance application #VR16-1015 – The applicant requests approval of a variance to allow an addition to an existing detached accessory building of 692 square feet (where 600 square feet is the maximum). Property is located at 100 Alamo Ranch Road.
- Action requested: accept report, take public comment, discuss.
  - Make recommendation to Supervisor Andersen, if applicable.

**Public Comment:**

**Mike Gibson, representing AIA**

**Member McDonald recommended 'APPROVAL' of the application as presented. Second by DeFerrari. Ayes: McDonald, DeFerrari, Mick, Barclay, Best and Rock. Nays: None. Motion APPROVED.**

- C. Variance application #VR16-1017 – The applicant requests approval of a variance for the purpose of modifying an existing accessory building that results in the creation of a second level totaling 594 square feet. The proposed accessory structure totals approximately 1,001 square feet (where 600 square feet is the maximum allowed) with a height of 23 feet, 8.75 inches (where 15 feet is the maximum height allowed). Project is located at 321 Livorna Heights Road.
- Action requested: accept report, take public comment, discuss.
  - Make recommendation to Supervisor Andersen, if applicable.

**Public Comment:**

**Mike Gibson, representing AIA**

**Stuart Donaldson**

**Joyce Grippi**

**James King**

**Jeanne LaTorre**

**Member Barclay recommended to 'DENY' the project as presented with a second by Member DeFerrari. The impact was too great on the neighbors and there was no special circumstance warranted to grant the findings for an approval. Ayes: Barclay, McDonald, DeFerrari, Mick, Rock, Winspear, and Best. Nays: None.**

- D. Hap Magee Ranch Park Proposed Budgets for Operations and Capital Improvements for 2016-17 (Town of Danville), presented by Victoria Skerritt, Special Districts.
- Action requested: accept report, take public comment, discuss.
  - Make Recommendation to Supervisor Andersen, if applicable.

**Motion by Member Best to approve the budget as presented. Second by Member McDonald. Ayes: Best, McDonald, Barclay, DeFerrari, Winspear, and Rock. Abstain: Mick**

- E. Budgets for CSA R-7A, Zones 36, 45 and 54: 2015-16 mid-year financial reports and proposed budgets for 2016-17, presented by Victoria Skerritt, Special Districts.
- Action requested: accept report, take public comment, discuss.
  - Make Recommendation to Supervisor Andersen, if applicable.

**Motion by Member Best to approve the budget as presented. Second by Member McDonald. Ayes: Best, McDonald, Barclay, DeFerrari, Winspear, Mick and Rock.**

- F. YMCA Alamo Recreation Program: Enrollment and CSA R-7A spending for program year from spring 2015 through winter 2016, presented by Victoria Skerritt, Special Districts.
- Action requested: accept report, take public comment, discuss.
  - Make Recommendation to Supervisor Andersen, if applicable.

**Motion by Member Best to approve the budget as presented. Second by Member McDonald. Ayes: Best, McDonald, Barclay, DeFerrari, Winspear, Mick and Rock.**

**6. OLD BUSINESS**

- A. 2016 Alamo Summer Events: Update on advertising and flyer distribution, presented by Victoria Skerritt, Special Districts.

**Marketing has started for the Summer Concert and Movie evens at Livorna Park.**

7. **CONSENT CALENDAR**

All matters listed under CONSENT CALENDAR are considered by the Alamo MAC to be routine and will be enacted by one motion. There will be no separate discussion of these items unless requested by a member of the Alamo MAC or a member of the public prior to the time the Alamo MAC votes on the motion to adopt.

A. Approve April 5 2016 Record of Actions

*Member Best moved to approve the above noted ROA's. Second by McDonald. Ayes: Best, McDonald, Rock, DeFerrari, Barclay and Mick.*

8. **SUBCOMMITTEE REPORTS** - \*Updates provided when available\*

Alamo AOB Subcommittee for Schools: Best, Mick and Rock  
Alamo AOB Subcommittee for Downtown: Rock, Barclay, McDonald, and Winspear  
Alamo Police Services Advisory Committee: Winspear

*Member Winspear reported on the May 2nd meeting of APSAC. Alamo has a new CHP office, Jason Joiner, patrolling Alamo. It was also reported that Lt. Haynes is preparing/reviewing a proposal for Automated License Plate Reader cameras that could be placed throughout Alamo to deter crime. Currently 26 cameras are being considered.*

Land Use Planning Working Group: Barclay, Winspear and McDonald  
Parks and Recreation Working Group: Barclay, Best, Winspear and Mick  
Hap Magee Dog Park Subcommittee: Michael McDonald

9. **CORRESPONDENCE** (the following items are listed for informational purposes only and may be considered for discussion during a future meeting).

A. None.

10. **COMMENTS BY MEMBERS OF THE ALAMO MAC**

A. Member Mick highlighted the Alamo Community Walk-About taking place on Thursday, May 19, from 5:00 to 8:00 PM.

11. **FUTURE AGENDA ITEMS**

A. Consideration of revision to County Tree Ordinance.

12. **ADJOURNMENT**

A. Meeting adjourned at 7:41 p.m. to the Alamo MAC meeting on **June 7** at 6:00 P.M. at the Alamo Women's Club located at 1401 Danville Boulevard, Alamo.

The Alamo Municipal Advisory Council will provide reasonable accommodations for persons with disabilities planning to attend the meeting who contact Supervisor Candace Andersen's office at least 72 hours before the meeting at 925-957-8860.

Materials distributed for the meeting are available for viewing at the District 2 Office at 309 Diablo Road, Danville, CA 94526. To receive a copy of the Alamo MAC agenda via mail or email, please submit your request in writing using a speaker card or by contacting Supervisor Andersen's office at 925-957-8860. Complete name and address must be submitted to be added to the list.

## Alamo Parks and Recreation, CSA R-7A 2nd Quarter Finance Report and 2016-17 Budget

		FY 15/16	FY 15/16	FY 15/16	FY 16/17
		Budget	Year to Date 12/31/2015	Estimated End of Year Totals	Proposed Budget
<b>7758</b>	<b>County Service Area R-7A</b>				
	<b>Fund Balance</b>	<b>3,509,224</b>	<b>3,509,224</b>	<b>\$3,509,224</b>	<b>\$3,757,551</b>
Ledger Code	<b>REVENUE:</b>				
9000, 9100, 9385, 9580	Taxes	931,860	1,001,723	1,001,723	1,000,000
9400	Interest Earned	4,000	10,800	14,722	12,000
9500-9595	Measure WW Funds	721,255	0	287,504	432,347
9600	Alamo Sports Field Fees	6,000	0	5,500	6,000
	<b>TOTAL REVENUE</b>	<b>1,663,115</b>	<b>1,012,523</b>	<b>1,309,448</b>	<b>1,450,347</b>
	<b>REVENUE PLUS FUND BALANCE</b>	<b>5,172,339</b>	<b>4,521,746</b>	<b>4,818,672</b>	<b>5,207,898</b>
	<b>EXPENSES:</b>				
	<b>Services and Supplies</b>				
2100	Office Expense	100	0	100	100
2120	Utilities	10,000	4,550	10,000	10,000
2281/2282	Trash/Custodial	16,000	8,275	16,000	16,000
2310	Hap Magee Operations	184,571	82,208	177,795	190,186
2310	YMCA Services	33,400	16,658	33,000	33,110
2310	Other Contracted Services	34,733	10,250	25,527	26,502
Various	Recreation Supplies	11,400	3,894	11,400	11,198
<b>SUBTOTAL</b>	<b>Services and Supplies Total</b>	<b>290,204</b>	<b>125,834</b>	<b>273,822</b>	<b>287,096</b>
	<b>Other Charges</b>				
3611	County Counsel; Assessment Admin.	10,600	50	9,600	10,600
3619	Prop Tax, Lease Management	6,100	0	2,724	6,100
3620	Grounds Maintenance	233,000	140,990	250,500	254,500
<b>SUBTOTAL</b>	<b>Other Charges Total</b>	<b>249,700</b>	<b>141,040</b>	<b>262,824</b>	<b>271,200</b>
	<b>Fixed Assets (Capital Improvements)</b>				
4766	Hap Magee Park Imps	58,200	3,149	14,452	82,500
4703	Hemme Station Park	1,500,000	49,802	100,000	1,400,000
4702	Livorna Park Bocce Ball Courts	759,539	34,886	287,504	432,347
<b>SUBTOTAL</b>	<b>Fixed Assets (Capital Improvements) Total</b>	<b>2,317,739</b>	<b>87,837</b>	<b>401,956</b>	<b>1,914,847</b>
	<b>Public Works Staff (Administration)</b>				
5011	Public Works Staff (Administration)	120,900	56,267	122,519	138,900
<b>SUBTOTAL</b>	<b>Public Works Staff (Administration) Total</b>	<b>120,900</b>	<b>56,267</b>	<b>122,519</b>	<b>138,900</b>
	<b>SUB-TOTAL EXPENSES</b>	<b>2,978,543</b>	<b>410,977</b>	<b>1,061,121</b>	<b>2,612,043</b>
	<b>Net</b>	<b>-1,315,428</b>	<b>601,546</b>	<b>248,327</b>	<b>-1,161,696</b>
	Capital Reserve	2,193,796	0	0	2,595,855
	<b>TOTAL EXPENSES</b>	<b>5,172,339</b>	<b>410,977</b>	<b>1,061,121</b>	<b>5,207,898</b>
	<b>Fund Balance (Park Development/Reserve)</b>	<b>\$0</b>	<b>\$4,110,769</b>	<b>\$3,757,551</b>	<b>\$0</b>
	<b>ADDITIONAL PARK DEVELOPMENT FUNDS - ALAMO</b>				
	Park Dedication Fees	\$208,917			
	Measure WW (EBRPD Bond)	\$817,931			
	Less amt reimbursed as of 6/30/15	<\$96,676>	(Note: Measure WW funds must be spent by 12/31/2018.)		
	<b>Measure WW Balance</b>	<b>\$721,255</b>			

**Alamo Parks and Recreation, CSA R-7A**  
**2nd Quarter Financial Variance Statement 2015-16**

		FY 15/16	FY 15/16	FY 15/16	Notes
7758	County Service Area R-7A	Budget	Year to Date 12/31/2015	% of Variance	Comments
	Fund Balance	\$3,509,224	\$3,509,224		
Ledger Code	REVENUE:				
9000, 9100, 9385, 9580	Taxes	931,860	1,001,723	107%	
9400	Interest Earned	4,000	10,800	270%	Interest is applied in July and January.
9500-9595	Measure WW Funds	721,255	0	0%	
9600	Alamo Sports Field Fees	6,000	0	0%	
	<b>TOTAL REVENUE</b>	<b>1,663,115</b>	<b>1,012,523</b>	<b>61%</b>	
	<b>REVENUE PLUS FUND BALANCE</b>	<b>5,172,339</b>	<b>4,521,746</b>	<b>87%</b>	
	EXPENSES:				
	Services and Supplies				
2100	Office Expense	100	0	0%	
2120	Utilities	10,000	4,550	45%	
2281/2282	Trash/Custodial	16,000	8,275	52%	
2310	Hap Magee Operations	184,571	82,208	45%	2014-15 4th Quarter Expense \$45,339.49. 2015-16 1st Quarter Expense \$36,868.28.
2310	YMCA Services	33,400	16,658	50%	2015 Spring Session \$6,334.38. 2015 Summer Session \$5,259.89. 2015 Fall Session \$5,063.28.
2310	Other Contracted Services	34,733	10,250	30%	
Various	Recreation Supplies	11,400	3,894	34%	
<b>SUBTOTAL</b>	<b>Services and Supplies Total</b>	<b>290,204</b>	<b>125,834</b>	<b>43%</b>	
	Other Charges				
3611	County Counsel; Assessment Admin.	10,600	50	0%	
3619	Prop Tax, Lease Management	6,100	0	0%	
3620	Grounds Maintenance	233,000	140,990	61%	
<b>SUBTOTAL</b>	<b>Other Charges Total</b>	<b>249,700</b>	<b>141,040</b>	<b>56%</b>	
	Fixed Assets (Capital Improvements)				
4766	Hap Magee Park Imps	58,200	3,149	5%	
4703	Hemme Station Park Construction	1,500,000	49,802	3%	
4702	Livorna Park Bocce Ball Courts	759,539	34,886	5%	
<b>SUBTOTAL</b>	<b>Fixed Assets (Capital Improvements)</b>	<b>2,317,739</b>	<b>87,837</b>	<b>4%</b>	
	Public Works Staff (Administration)				
5011	Public Works Staff (Administration)	120,900	56,267	47%	
<b>SUBTOTAL</b>	<b>Public Works Staff (Administration)</b>	<b>120,900</b>	<b>56,267</b>	<b>47%</b>	
	<b>TOTAL EXPENSES</b>	<b>2,978,543</b>	<b>410,977</b>	<b>14%</b>	
	Net	-1,315,428	601,546	-46%	
	Fund Balance	\$2,193,796	\$4,110,769	187%	



**Alamo Parks and Recreation, CSA R-7A**  
**Administration and Miscellaneous**  
**2nd Quarter Finance Report and 2016-17 Budget**

	FY15/16	FY15/16	FY15/16	FY16/17
	Budget	Year to Date 12/31/2015	Estimated End of Year Totals	Proposed Budget
Service and Supplies	\$10,000	\$152	300	300
County Counsel; Assessment Admin.	10,000	50	9,000	10,000
YMCA Program	33,400	16,658	33,000	33,110
Public Works Staff (Administration)	60,100	36,621	73,242	74,000
<b>Total</b>	<b>113,500</b>	<b>53,481</b>	<b>115,542</b>	<b>117,410</b>

# Alamo Parks and Recreation, CSA R-7A

## Parks

### 2nd Quarter Finance Report and 2016-17 Budget

Livorna Park					
	FY15/16	FY15/16	FY15/16	FY 16/17	FY15/16
	Budget	Year to Date 12/31/2015	Estimated End of Year Totals	Proposed Budget	Bocce Ball Court Costs
Services and Supplies	\$33,000	\$12,215	33,000	33,000	\$18,448
Grounds Maintenance	160,000	89,264	170,000	170,000	16,438
Livorna Park Bocce Ball Courts	759,539	34,886	287,504	432,347	34,886
Public Works Staff (Administration)	25,000	3,191	10,000	25,000	
<b>Total</b>	<b>977,539</b>	<b>139,557</b>	<b>500,504</b>	<b>660,347</b>	
Alamo Elementary School					
Services and Supplies	5,000	2,256	5,000	5,000	
Grounds Maintenance	35,000	19,462	35,000	45,000	
Public Works Staff (Admin.)	4,000	2,492	5,000	4,000	
<b>Total</b>	<b>44,000</b>	<b>24,211</b>	<b>45,000</b>	<b>54,000</b>	
Andrew H. Young Park					
Services and Supplies	3,000	2,503	3,000	3,000	
Grounds Maintenance	35,000	31,423	43,000	35,000	
Public Works Staff (Admin.)	2,000	399	2,000	2,000	
<b>Total</b>	<b>40,000</b>	<b>34,324</b>	<b>48,000</b>	<b>40,000</b>	
Rancho Romero School					
Prop Tax/Insurance, Lease Management	100	0	100	100	
Public Works Staff (Admin.)	100	0	100	100	
<b>Total</b>	<b>200</b>	<b>0</b>	<b>200</b>	<b>200</b>	
Hap Magee Ranch Park					
Hap Magee Operations (Supplies & Services)	184,571	82,208	177,795	190,186	
County Counsel	600	0	600	600	
Prop Tax, Lease Management	6,000	0	2,624	6,000	
Capital Improvements	58,200	3,149	14,452	82,500	
Public Works Staff (Admin.)	1,000	61	1,000	1,000	
<b>Total</b>	<b>250,371</b>	<b>85,418</b>	<b>196,471</b>	<b>280,286</b>	
Iron Horse Trail Corridor					
Grounds Maintenance	3,000	198	1,000	3,000	
Public Works Staff (Admin.)	1,000	0	100	1,000	
<b>Total</b>	<b>4,000</b>	<b>198</b>	<b>1,100</b>	<b>4,000</b>	<b>FY15/16</b>
Hemme Station Park					
Grounds Maintenance	1,500	643	1,500	1,500	<b>Hemme Costs</b>
Hemme Station Park	1,500,000	49,802	100,000	1,400,000	\$14,795
<b>Total</b>	<b>1,501,500</b>	<b>50,445</b>	<b>101,500</b>	<b>1,401,500</b>	35,007
<b>49,802</b>					
Parks Summary					
	FY15/16	FY15/16	FY15/16	FY 16/17	
	BUDGET	Year to Date 12/31/2015	Estimated End of Year Totals	Proposed Budget	
Services and Supplies	225,571	99,182	218,795	231,186	
Grounds Maintenance and other charges	239,700	140,990	253,824	261,200	
Capital Improvements	2,317,739	87,837	401,956	1,914,847	
Public Works Staff (Admin.)	33,100	6,144	18,200	33,100	
<b>Total</b>	<b>2,816,110</b>	<b>334,152</b>	<b>892,775</b>	<b>2,440,333</b>	

# Alamo Parks and Recreation, CSA R-7A

## Events

### 2nd Quarter Finance Report and 2016-17 Budget

	FY15/16	FY15/16	FY15/16	FY16/17
	Budget	Year to Date 12/31/2015	End of Year Totals	Proposed Budget
<b>Movie Under the Stars</b>				
Services and Supplies	\$4,000	\$942	3,500	4,000
Public Works Staff (Administration)	8,000	4,592	8,303	8,500
<b>Total</b>	<b>12,000</b>	<b>5,535</b>	<b>11,803</b>	<b>12,500</b>
<b>Summer Concert Series</b>				
Services and Supplies	15,305	7,400	16,727	17,000
Public Works Staff (Administration)	19,000	8,642	22,506	23,000
<b>Total</b>	<b>34,305</b>	<b>16,042</b>	<b>39,233</b>	<b>40,000</b>
<b>Alamo Music Festival</b>				
Services and Supplies	500	0	0	0
Public Works Staff (Administration)	500	0	0	0
<b>Total</b>	<b>1,000</b>	<b>0</b>	<b>0</b>	<b>0</b>
<b>Tree Lighting</b>				
Services and Supplies	1,500	1,500	1,500	1,500
Public Works Staff (Administration)	200	268	268	300
<b>Total</b>	<b>1,700</b>	<b>1,768</b>	<b>1,768</b>	<b>1,800</b>
<b>Events Summary</b>				
	FY15/16	FY15/16	FY15/16	FY16/17
	BUDGET	12/31/2015	End of Year	Budget
Services and Supplies	21,305	9,842	21,727	22,500
Public Works Staff (Administration)	27,700	13,502	31,077	31,800
<b>Total Event Summary</b>	<b>49,005</b>	<b>23,344</b>	<b>52,804</b>	<b>54,300</b>



Contra  
Costa  
County

To: Board of Supervisors  
From: David Twa, County Administrator  
Date: November 1, 2016

Subject: Claims

---

**RECOMMENDATION(S):**

DENY claims filed by Clark Pest Control, David Hofman, Jason Hunt, Seth Krubiner, Eugene Mangini, Howard Perdue, Denise Smullen, State Farm Insurance for Pierin Daberdaku Claim and Dillon Vassey, a minor.

**FISCAL IMPACT:**

No fiscal impact.

**BACKGROUND:**

\*

---

APPROVE  OTHER  
 RECOMMENDATION OF CNTY ADMINISTRATOR  RECOMMENDATION OF BOARD COMMITTEE

---

Action of Board On: 11/01/2016  APPROVED AS RECOMMENDED  OTHER

Clerks Notes:

**VOTE OF SUPERVISORS**

AYE: John Gioia, District I Supervisor  
Mary N. Piepho, District III Supervisor  
Karen Mitchoff, District IV Supervisor  
Federal D. Glover, District V Supervisor

I hereby certify that this is a true and correct copy of an action taken and entered on the minutes of the Board of Supervisors on the date shown.

ATTESTED: November 1, 2016  
David J. Twa, County Administrator and Clerk of the Board of Supervisors

RECUSE: Candace Andersen, District II Supervisor

By: Stephanie Mello, Deputy

Contact: Joellen Balbas  
925-335-1906

cc:



Contra  
Costa  
County

To: Board of Supervisors  
From: William Walker, M.D., Health Services Director  
Date: November 1, 2016

Subject: Recognizing Karen Shular for her service to the Mental Health Commission and the Behavioral Health Division of Health Services

---

---

APPROVE  OTHER  
 RECOMMENDATION OF CNTY ADMINISTRATOR  RECOMMENDATION OF BOARD COMMITTEE

---

Action of Board On: **11/01/2016**  APPROVED AS RECOMMENDED  OTHER

Clerks Notes:

**VOTE OF SUPERVISORS**

AYE: John Gioia, District I Supervisor  
Candace Andersen, District II Supervisor  
Mary N. Piepho, District III Supervisor  
Karen Mitchoff, District IV Supervisor  
Federal D. Glover, District V Supervisor

I hereby certify that this is a true and correct copy of an action taken and entered on the minutes of the Board of Supervisors on the date shown.

ATTESTED: November 1, 2016  
David J. Twa, County Administrator and Clerk of the Board of Supervisors

By: Stephanie Mello, Deputy

Contact: Cynthia Belon, (925) 957-5201

cc:

AGENDA

ATTACHMENTS

Resolution No. 2016/631

MINUTES

ATTACHMENTS

Signed Resolution No. 631

*The Board of Supervisors of  
Contra Costa County, California*

In the matter of:

**Resolution No. 2016/631**

**Recognizing Karen Shuler for her service to the Mental Health Commission and the Behavioral Health Division of the Health Services Department.**

WHEREAS, Ms. Karen Shuler served the Mental Health Commission and the Behavioral Health Division of the Health Services Department for more than 15 years; and

WHEREAS, Ms. Shuler continuously supported the goals and mission of the Mental Health Commission, working tirelessly to advance the objectives of the commission; and

WHEREAS, Ms. Shuler enthusiastically supported the needs of Mental Health Commissioners and provided timely and necessary information to support their work; and

WHEREAS, Ms. Shuler represented the Behavioral Health Division with professionalism and maintained a tremendous work attitude, pleasantness, and cheerful demeanor towards her co-workers in the Behavioral Health Division; and

WHEREAS, Ms. Shuler impeccably kept the affairs and records of the Mental Health Commission in accordance with applicable laws and provisions required for the maintenance of a public body; and

WHEREAS, the Mental Health Commission has been most fortunate to have had a person of her talent and dedication for the past 15 years of loyal service; and

WHEREAS, Ms. Shuler will be truly missed by her co-workers, members of the Mental Health Commission and the members of the community of which she has faithfully served.

NOW, THEREFORE, BE IT RESOLVED that the Contra Costa County Board of Supervisors does hereby recognize Ms. Karen Shuler for her many contributions to the Contra Costa County Mental Health Commission and Behavioral Health Division of the Health Services Department and wishes her the best in her continued endeavors to support the well being of Contra Costa County residents.

\_\_\_\_\_  
**CANDACE ANDERSEN**

Chair,  
District II Supervisor

\_\_\_\_\_  
**JOHN GIOIA**  
District I Supervisor

\_\_\_\_\_  
**MARY N. PIEPHO**  
District III Supervisor

\_\_\_\_\_  
**KAREN MITCHOFF**  
District IV Supervisor

\_\_\_\_\_  
**FEDERAL D. GLOVER**  
District V Supervisor

I hereby certify that this is a true and correct copy of an action taken and entered on the minutes of the Board of Supervisors on the date shown.

ATTESTED: November 1, 2016

David J. Twa,

By: \_\_\_\_\_, Deputy

# Board of Supervisors of Contra Costa County, California

**IN THE MATTER OF RECOGNIZING KAREN SHULER FOR  
HER SERVICE TO THE MENTAL HEALTH COMMISSION  
AND THE BEHAVIORAL HEALTH DIVISION OF THE  
HEALTH SERVICES DEPARTMENT**

**RESOLUTION NO. 2016/631**

WHEREAS, Ms. Karen Shuler served the Mental Health Commission and the Behavioral Health Division of the Health Services Department for more than 15 years; and

WHEREAS, Ms. Shuler continuously supported the goals and mission of the Mental Health Commission, working tirelessly to advance the objectives of the commission; and

WHEREAS, Ms. Shuler enthusiastically supported the needs of Mental Health Commissioners and provided timely and necessary information to support their work; and

WHEREAS, Ms. Shuler represented the Behavioral Health Division with professionalism and maintained a tremendous work attitude, pleasantness, and cheerful demeanor towards her co-workers in the Behavioral Health Division; and

WHEREAS, Ms. Shuler impeccably kept the affairs and records of the Mental Health Commission in accordance with applicable laws and provisions required for the maintenance of a public body; and

WHEREAS, the Mental Health Commission has been most fortunate to have had a person of her talent and dedication for the past 15 years of loyal service; and

WHEREAS, Ms. Shuler will be truly missed by her co-workers, members of the Mental Health Commission and the members of the community of which she has faithfully served.

**NOW, THEREFORE, BE IT RESOLVED** that the Board of Supervisors of Contra Costa County does hereby recognize

*Ms. Karen Shuler*

for her many contributions to the Contra Costa County Mental Health Commission and Behavioral Health Division of the Health Services Department and wishes her the best in her continued endeavors to support the wellbeing of Contra Costa County residents.

**PASSED** by a unanimous vote of the Board of Supervisors members present this 1<sup>ST</sup> day of November, 2016.

*Candace Andersen*

**CANDACE ANDERSEN**  
Chair,  
District II Supervisor

*John Gioia*

**JOHN GIOIA**  
District I Supervisor

*Mary N. Piepho*

**MARY N. PIEPHO**  
District III Supervisor

*Karen Mitchoff*

**KAREN MITCHOFF**  
District IV Supervisor

*Federal D. Glover*

**FEDERAL D. GLOVER**  
District V Supervisor



I hereby certify that this is a true and correct copy of an action taken and entered on the minutes of the Board of Supervisors on the date shown:

ATTESTED: November 1, 2016

DAVID TWA, Clerk of the Board of Supervisors and County Administrator

By *Stephanis Mello*, Deputy





Contra  
Costa  
County

To: Board of Supervisors  
From: Joseph E. Canciamilla, Clerk-Recorder  
Date: November 1, 2016

Subject: Resolution Honoring Mary Whatford for More Than 28 years of Service to Contra Costa County

---

---

APPROVE

OTHER

RECOMMENDATION OF CNTY ADMINISTRATOR

RECOMMENDATION OF BOARD  
COMMITTEE

---

Action of Board On: **11/01/2016**  APPROVED AS RECOMMENDED  OTHER

Clerks Notes:

**VOTE OF SUPERVISORS**

AYE: John Gioia, District I Supervisor  
Candace Andersen, District II  
Supervisor  
Mary N. Piepho, District III  
Supervisor  
Karen Mitchoff, District IV  
Supervisor  
Federal D. Glover, District V  
Supervisor

I hereby certify that this is a true and correct copy of an action taken and entered on the minutes of the Board of Supervisors on the date shown.

ATTESTED: November 1, 2016

David J. Twa, County Administrator and Clerk of the Board of Supervisors

By: Stephanie Mello, Deputy

Contact: 925-335-7899

cc:

AGENDA

ATTACHMENTS

Resolution No. 2016/567

MINUTES

ATTACHMENTS

Signed Resolution No. 567

*The Board of Supervisors of  
Contra Costa County, California*

In the matter of:

**Resolution No. 2016/567**

**Recognizing Mary Whatford upon her retirement as Recorder Operations Manager in the Contra Costa County Clerk-Recorder Department.**

Whereas, Mary Whatford joined the Contra Costa County Clerk-Recorder Department on June 7, 1988; and  
Whereas, Mary oversaw the Department's Recording Unit beginning in August, 1996; holding many titles as she progressed through the ranks to serve the last 18 years as Recorders Operations Manager; and  
Whereas, during Mary's tenure she oversaw the recording, imaging, and indexing of more than **10,000,000** documents by the Recording Unit, making possible the constructive notice of real property transactions to the public; and

Whereas, Mary lead the successful implementation of Department's Electronic Document Recording System which has grown to account for more than 50 percent of documents submitted for recording; and  
Whereas, Mary excelled as a liaison with Title Companies; interfacing with them daily and providing excellent customer service that elicited endless compliments and praise; and

Whereas, Mary was responsible for the development of a Deputy Commissioner of Marriage training program in which she trained and mentored staff by drawing from her own years of experience by joining approximately 5,000 couples in matrimony – an activity she expressed as fulfilling and “warming” to the heart; and

Whereas, while working full time for the Clerk-Recorder Department, Mary concurrently enjoyed a long and extensive career as a basketball referee, moving up the ranks from officiating youth and high school basketball to junior college and Division 1 women's college games including Pac 12, Big Sky, WCC, and WAC conferences, as well as NCC post season tournaments; and

Whereas, Mary is an avid cyclist, having participated in the Lake Tahoe Leukemia and Lymphoma Society and the Waves to Wine Multiple Sclerosis fundraising rides for many years; and

Whereas, Mary's dedication and strong work ethic are evidenced by her calling in sick only one day in 28 years; and

Whereas, Mary's most enjoyable “claim to fame” is sharing with people that she and Tom Hanks were both born in Contra Costa County on the same day (different year); and

Whereas, Mary dedicated more than 28 years to serving the residents of Contra Costa County and beyond, and now looks forward to pursuing other passions and spending time with family and friends, including camping and traveling;

NOW, THEREFORE, BE IT RESOLVED that the Board of Supervisors of Contra Costa County does hereby congratulate, thank, and honor Mary Whatford for her remarkable service and dedication to Contra Costa County.

\_\_\_\_\_  
**CANDACE ANDERSEN**

Chair,  
District II Supervisor

\_\_\_\_\_  
**JOHN GIOIA**  
District I Supervisor

\_\_\_\_\_  
**MARY N. PIEPHO**  
District III Supervisor

\_\_\_\_\_  
**KAREN MITCHOFF**  
District IV Supervisor

\_\_\_\_\_  
**FEDERAL D. GLOVER**  
District V Supervisor

I hereby certify that this is a true and correct copy of an action taken and entered on the minutes of the Board of Supervisors on the date shown.

ATTESTED: November 1, 2016

David J. Twa,

By: \_\_\_\_\_, Deputy

C.5

*Board of Supervisors of  
Contra Costa County, California*

**IN THE MATTER OF RECOGNIZING MARY WHATFORD  
UPON HER RETIREMENT AS RECORDER OPERATIONS  
MANAGER IN THE CONTRA COSTA COUNTY  
CLERK-RECORDER DEPARTMENT**

**RESOLUTION NO. 2016/567**

WHEREAS, Mary Whatford joined the Contra Costa County Clerk-Recorder Department on June 7, 1988; and

WHEREAS, Mary oversaw the Department's Recording Unit beginning in August, 1996; holding many titles as she progressed through the ranks to serve the last 18 years as Recorders Operations Manager; and

WHEREAS, during Mary's tenure she oversaw the recording, imaging, and indexing of more than 10,000,000 documents by the Recording Unit, making possible the constructive notice of real property transactions to the public; and

WHEREAS, Mary lead the successful implementation of Department's Electronic Document Recording System which has grown to account for more than 50 percent of documents submitted for recording; and

WHEREAS, Mary excelled as a liaison with Title Companies; interfacing with them daily and providing excellent customer service that elicited endless compliments and praise; and

WHEREAS, Mary was responsible for the development of a Deputy Commissioner of Marriage training program in which she trained and mentored staff by drawing from her own years of experience by joining approximately 5,000 couples in matrimony – an activity she expressed as fulfilling and "warming" to the heart; and

WHEREAS, while working full time for the Clerk-Recorder Department, Mary concurrently enjoyed a long and extensive career as a basketball referee, moving up the ranks from officiating youth and high school basketball to junior college and Division 1 women's college games including Pac 12, Big Sky, WCC, and WAC conferences, as well as NCC post season tournaments; and

WHEREAS, Mary is an avid cyclist, having participated in the Lake Tahoe Leukemia and Lymphoma Society and the Waves to Wine Multiple Sclerosis fundraising rides for many years; and

WHEREAS, Mary's dedication and strong work ethic are evidenced by her calling in sick only one day in 28 years; and

WHEREAS, Mary's most enjoyable "claim to fame" is sharing with people that she and Tom Hanks were both born in Contra Costa County on the same day (different year); and

WHEREAS, Mary dedicated more than 28 years to serving the residents of Contra Costa County and beyond, and now looks forward to pursuing other passions and spending time with family and friends, including camping and traveling.

**NOW, THEREFORE, BE IT RESOLVED** that the Board of Supervisors of Contra Costa County does hereby congratulate, thank, and honor

*Mary Whatford*

for her remarkable service and dedication to Contra Costa County.

**PASSED** by a unanimous vote of the Board of Supervisors members present this 1<sup>ST</sup> day of November, 2016.

  
CANDACE ANDERSEN

Chair,  
District II Supervisor

  
JOHN GIOIA  
District I Supervisor

  
KAREN MITCHOFF  
District IV Supervisor

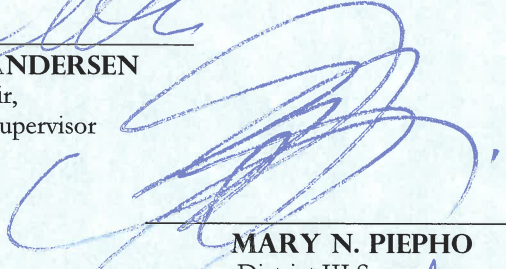
  
MARY N. PIEPHO  
District III Supervisor

  
FEDERAL D. GLOVER  
District V Supervisor



I hereby certify that this is a true and correct copy of an action taken and entered on the minutes of the Board of Supervisors on the date shown:

ATTESTED: November 1, 2016

DAVID TWA, Clerk of the Board of Supervisors and County Administrator

By Stephanie Mello, Deputy



Contra  
Costa  
County

To: Board of Supervisors  
From: John Gioia, District I Supervisor  
Date: November 1, 2016

Subject: Honoring the Contra Costa Chorale on its 50th Anniversary

---

---

APPROVE

OTHER

RECOMMENDATION OF CNTY  
ADMINISTRATOR

RECOMMENDATION OF BOARD  
COMMITTEE

---

Action of Board On: **11/01/2016**  APPROVED AS  
RECOMMENDED

OTHER

Clerks Notes:

**VOTE OF SUPERVISORS**

AYE: John Gioia, District I Supervisor  
Candace Andersen, District II  
Supervisor  
Mary N. Piepho, District III  
Supervisor  
Karen Mitchoff, District IV  
Supervisor  
Federal D. Glover, District V  
Supervisor

I hereby certify that this is a true and correct copy of an action taken and entered on the minutes of the Board  
of Supervisors on the date shown.

ATTESTED: November 1, 2016

David J. Twa, County Administrator and Clerk of the Board of Supervisors

By: Stephanie Mello, Deputy

Contact: Kate Rauch 510-231-8691

cc:

AGENDA

ATTACHMENTS

Resolution No. 2016/578

MINUTES

ATTACHMENTS

Signed Resolution No. 578

*The Board of Supervisors of  
Contra Costa County, California*

In the matter of:

**Resolution No. 2016/578**

**Honoring the Contra Costa Chorale on its 50th Anniversary of Community-Driven Musical Excellence**

WHEREAS, the Contra Costa Chorale was formed in 1966 as the Richmond Symphony Chorus under the leadership of Joseph Liebling; and

WHEREAS, when the Richmond Symphony Orchestra disbanded, the Richmond Symphony Chorus was taken under the wing of Contra Costa College as one of its community education offerings; and

WHEREAS, through the past 50 years the Contra Costa Symphony Chorus and later the Contra Costa Chorale has performed a diverse repertoire of classical and popular choral music for residents of Contra Costa County; and

WHEREAS, in its history the Contra Costa Chorale has sung under the leadership of a number of talented choral directors, including Milton Williams, Paul Perry, Dick Kramer, Michael Carlson, and John Montanero; and

WHEREAS, since 2012 Cindy Beitmen has been the director of the Chorale and has inspired the group to new artistic heights; and

WHEREAS, the Contra Costa Chorale has annually serenaded groups throughout the Bay Area during the holidays; and

WHEREAS, the Contra Costa Chorale has recently become the “go-to” chorus for the Star Spangled Banner; and

WHEREAS, some of the original members of the Contra Costa Chorale are still singing with the group today; and

WHEREAS, the Contra Costa Chorale is looking forward to expanding its presence in Contra Costa County, particularly in the schools; and

WHEREAS, the Chorale’s fall concert, “I Love You California,” will feature California’s rich musical heritage from the time of the missions through the 21st century.

Now, Therefore, Be It Resolved that the Board of Supervisors of Contra Costa County does hereby congratulate and honor the the esteemed Contra Costa Chorale on fifty years of providing musical excellence by and for the community.

\_\_\_\_\_  
**CANDACE ANDERSEN**

Chair,  
District II Supervisor

\_\_\_\_\_  
**JOHN GIOIA**  
District I Supervisor

\_\_\_\_\_  
**MARY N. PIEPHO**  
District III Supervisor

\_\_\_\_\_  
**KAREN MITCHOFF**  
District IV Supervisor

\_\_\_\_\_  
**FEDERAL D. GLOVER**  
District V Supervisor

I hereby certify that this is a true and correct copy of an action taken and entered on the minutes of the Board of Supervisors on the date shown.

ATTESTED: November 1, 2016

David J. Twa,

By: \_\_\_\_\_, Deputy



PR.1, C.6

*Board of Supervisors of  
Contra Costa County, California*

**IN THE MATTER OF HONORING THE CONTRA COSTA  
CHORALE ON ITS 50TH ANNIVERSARY OF COMMUNITY-  
DRIVEN MUSICAL EXCELLENCE**

**RESOLUTION NO. 2016/578**

**WHEREAS**, the Contra Costa Chorale was formed in 1966 as the Richmond Symphony Chorus under the leadership of Joseph Liebling; and

**WHEREAS**, when the Richmond Symphony Orchestra disbanded, the Richmond Symphony Chorus was taken under the wing of Contra Costa College as one of its community education offerings; and

**WHEREAS**, through the past 50 years the Contra Costa Symphony Chorus and later the Contra Costa Chorale has performed a diverse repertoire of classical and popular choral music for residents of Contra Costa County; and

**WHEREAS**, in its history the Contra Costa Chorale has sung under the leadership of a number of talented choral directors, including Milton Williams, Paul Perry, Dick Kramer, Michael Carlson, and John Montanero; and

**WHEREAS**, since 2012 Cindy Beitmen has been the director of the Chorale and has inspired the group to new artistic heights; and

**WHEREAS**, the Contra Costa Chorale has annually serenaded groups throughout the Bay Area during the holidays; and

**WHEREAS**, the Contra Costa Chorale has recently become the "go-to" chorus for the Star Spangled Banner; and

**WHEREAS**, some of the original members of the Contra Costa Chorale are still singing with the group today; and

**WHEREAS**, the Contra Costa Chorale is looking forward to expanding its presence in Contra Costa County, particularly in the schools; and

**WHEREAS**, the Chorale's fall concert, "I Love You California," will feature California's rich musical heritage from the time of the missions through the 21st century.

**NOW, THEREFORE, BE IT RESOLVED** that the Board of Supervisors of Contra Costa County does hereby congratulate and honor the the esteemed

*Contra Costa Chorale*

on fifty years of providing musical excellence by and for the community.

**PASSED** by a unanimous vote of the Board of Supervisors members present this 1<sup>st</sup> day of November, 2016.

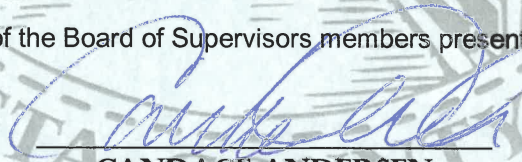

**CANDACE ANDERSEN**

Chair,  
District II Supervisor

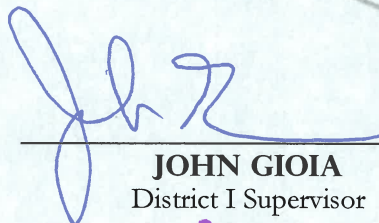

**JOHN GIOIA**  
District I Supervisor



**KAREN MITCHOFF**  
District IV Supervisor

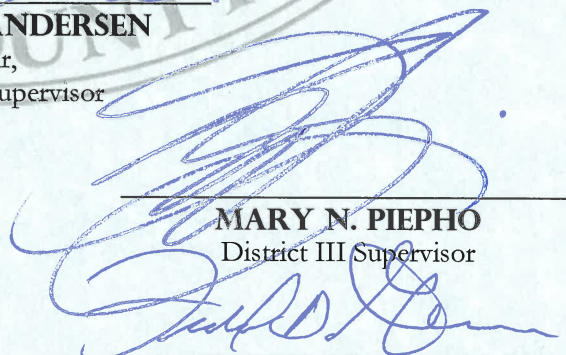

**MARY N. PIEPHO**  
District III Supervisor

  
**FEDERAL D. GLOVER**  
District V Supervisor



I hereby certify that this is a true and correct copy of an action taken and entered on the minutes of the Board of Supervisors on the date shown:

ATTESTED: November 1, 2016

DAVID TWA, Clerk of the Board of Supervisors and County Administrator

By Stephanie Mello, Deputy



Contra  
Costa  
County

To: Board of Supervisors  
From: John Gioia, District I Supervisor  
Date: November 1, 2016

Subject: Honoring Easter Hill United Methodist Church of Richmond on its 65th Anniversary

---

---

APPROVE  OTHER  
 RECOMMENDATION OF CNTY ADMINISTRATOR  RECOMMENDATION OF BOARD COMMITTEE

---

Action of Board On: **11/01/2016**  APPROVED AS RECOMMENDED  OTHER

Clerks Notes:

**VOTE OF SUPERVISORS**

AYE: John Gioia, District I Supervisor  
Candace Andersen, District II Supervisor  
Mary N. Piepho, District III Supervisor  
Karen Mitchoff, District IV Supervisor  
Federal D. Glover, District V Supervisor

I hereby certify that this is a true and correct copy of an action taken and entered on the minutes of the Board of Supervisors on the date shown.

ATTESTED: November 1, 2016

David J. Twa, County Administrator and Clerk of the Board of Supervisors

By: Stephanie Mello, Deputy

Contact: Kate Rauch 510-231-8691

cc:

AGENDA

ATTACHMENTS

Resolution No. 2016/605

MINUTES

ATTACHMENTS

Signed Resolution No. 605

*The Board of Supervisors of  
Contra Costa County, California*

In the matter of:

**Resolution No. 2016/605**

**Honoring Easter Hill United Methodist Church of Richmond, CA on its 65th Anniversary.**

Whereas, Easter Hill United Methodist Church was started in the late 1940's- early 1950's when residents identified the need for a Methodist church in South Richmond. It began with meetings in the apartment of Jones and Mattie Mann, where fundraising and other planning began for a permanent church; and  
Whereas, the early planning group raised \$1,600 which was used to buy a piece of property at 30th Street and Hoffman Blvd, the site of the first Easter Hill United Methodist Church, named for a small hill between 28th Street and Hoffman Blvd. in Richmond, where Easter Sunrise Worship was held. Several pastors served the early church during the planning stage including Rev. Dixon, followed by Rev. S.D. Rhone, Rev. Carr and Rev. W. B. Smith, and Rev. Wilbur R. Johnson, who arrived from Boston in 1951 to serve as Easter Hill United Methodist Church's first official pastor; and  
Whereas, the state needed the church's land for freeway expansion, so in 1956 it moved to 39th Street and Cutting Blvd. Rev. Booker Anderson lead Easter Hill Methodist faithfully from 1959 to 1969, a period when it was known as a Social Justice Church, counting Dr. Martin Luther King, Jr. among its distinguished speakers; and  
Whereas, over the next few decades as the church grew in congregants, activities and programs, several devoted and inspirational pastors led Easter Hill, including Rev. Dr. A. Edward Bell, Rev. Amos Cambridge, Rev. Max Brown, Rev. David Houston, Rev. Ronald Swisher, and Rev. Dorothy Williams, the first African-American female pastor ordained by the California-Nevada conference; and  
Whereas, approaching the turn of the century, East Hill pastors included Frederick G. Grey, Reginald Nichols, and Rev. Phillip Lawson, who served until he retired in 2003; and  
Whereas, in 1997, Easter Hill purchased property between 36th and 37th streets on Cutting Boulevard, opening a thrift store, and Family Life Center; and  
Whereas, after Rev. Lawson's retirement, Rev. Billye Austin led the church until his retirement in 2014 when Easter Hill's current pastor, Rev. Donald Francis Guest was appointed;  
Whereas, during this rich history, Easter Hill United Methodist church earned a reputation as a thriving center of spirituality, community service, and commitment to human rights; and  
Whereas, in 2016, Easter Hill is celebrating 65 years of inspired service to the people of Richmond and West Contra Costa County.

Now, Therefore, Be It Resolved that the Board of Supervisors of Contra Costa County does hereby honor Easter Hill United Methodist Church of Richmond, CA on its 65th Anniversary.

\_\_\_\_\_  
**CANDACE ANDERSEN**

Chair,  
District II Supervisor

\_\_\_\_\_  
**JOHN GIOIA**

District I Supervisor

\_\_\_\_\_  
**MARY N. PIEPHO**

District III Supervisor

\_\_\_\_\_  
**KAREN MITCHOFF**

District IV Supervisor

\_\_\_\_\_  
**FEDERAL D. GLOVER**

District V Supervisor

I hereby certify that this is a true and correct copy of an action taken and entered on the minutes of the Board of Supervisors on the date shown.

ATTESTED: November 1, 2016

David J. Twa,

By: \_\_\_\_\_, Deputy



# Board of Supervisors of Contra Costa County, California

IN THE MATTER OF HONORING EASTER HILL UNITED  
METHODIST CHURCH OF RICHMOND, CA ON ITS 65TH  
ANNIVERSARY

RESOLUTION NO. 2016/605

WHEREAS, Easter Hill United Methodist Church was started in the late 1940's- early 1950's when residents identified the need for a Methodist church in South Richmond. It began with meetings in the apartment of Jones and Mattie Mann, where fundraising and other planning began for a permanent church; and

WHEREAS, the early planning group raised \$1,600 which was used to buy a piece of property at 30th Street and Hoffman Blvd, the site of the first Easter Hill United Methodist Church, named for a small hill between 28th Street and Hoffman Blvd. in Richmond, where Easter Sunrise Worship was held. Several pastors served the early church during the planning stage including Rev. Dixon, followed by Rev. S.D. Rhone, Rev. Carr and Rev. W. B. Smith, and Rev. Wilbur R. Johnson, who arrived from Boston in 1951 to serve as Easter Hill United Methodist Church's first official pastor; and

WHEREAS, the state needed the church's land for freeway expansion, so in 1956 it moved to 39th Street and Cutting Blvd. Rev. Booker Anderson lead Easter Hill Methodist faithfully from 1959 to 1969, a period when it was known as a Social Justice Church, counting Dr. Martin Luther King, Jr. among its distinguished speakers; and

WHEREAS, over the next few decades as the church grew in congregants, activities and programs, several devoted and inspirational pastors led Easter Hill, including Rev. Dr. A. Edward Bell, Rev. Amos Cambridge, Rev. Max Brown, Rev. David Houston, Rev. Ronald Swisher, and Rev. Dorothy Williams, the first African-American female pastor ordained by the California-Nevada conference; and

WHEREAS, approaching the turn of the century, East Hill pastors included Frederick G. Grey, Reginald Nichols, and Rev. Phillip Lawson, who served until he retired in 2003; and

WHEREAS, in 1997, Easter Hill purchased property between 36th and 37th streets on Cutting Boulevard, opening a thrift store, and Family Life Center; and

WHEREAS, after Rev. Lawson's retirement, Rev. Billye Austin led the church until his retirement in 2014 when Easter Hill's current pastor, Rev. Donald Francis Guest was appointed; and

WHEREAS, during this rich history, Easter Hill United Methodist church earned a reputation as a thriving center of spirituality, community service, and commitment to human rights; and

WHEREAS, in 2016, Easter Hill is celebrating 65 years of inspired service to the people of Richmond and West Contra Costa County.

NOW, THEREFORE, BE IT RESOLVED that the Board of Supervisors of Contra Costa County does hereby honor

## *Easter Hill United Methodist Church*

of Richmond, CA on its 65th Anniversary.

PASSED by a unanimous vote of the Board of Supervisors members present this 1<sup>st</sup> day of November, 2016.

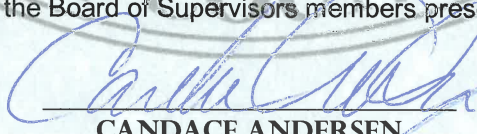

CANDACE ANDERSEN  
Chair,  
District II Supervisor

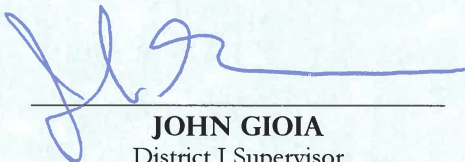

JOHN GIOIA  
District I Supervisor

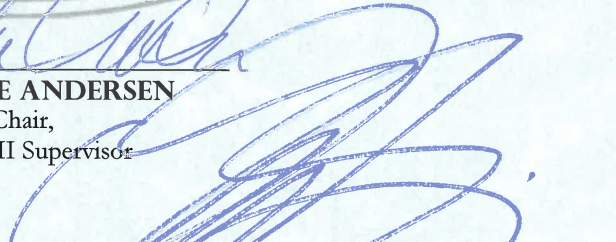
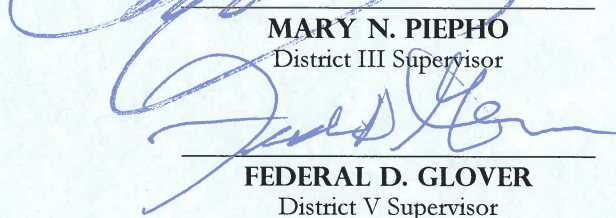

KAREN MITCHOFF  
District IV Supervisor

MARY N. PIEPHO  
District III Supervisor

FEDERAL D. GLOVER  
District V Supervisor



I hereby certify that this is a true and correct copy of an action taken and entered on the minutes of the Board of Supervisors on the date shown:

ATTESTED: November 1, 2016

DAVID TWA, Clerk of the Board of Supervisors and County Administrator

By Stephanie Mello, Deputy



Contra  
Costa  
County

To: Board of Supervisors  
From: Kathy Gallagher, Employment & Human Services Director  
Date: November 1, 2016

Subject: Adoption Awareness Month

---

---

APPROVE  OTHER  
 RECOMMENDATION OF CNTY ADMINISTRATOR  RECOMMENDATION OF BOARD COMMITTEE

---

Action of Board On: **11/01/2016**  APPROVED AS RECOMMENDED  OTHER

Clerks Notes:

**VOTE OF SUPERVISORS**

AYE: John Gioia, District I Supervisor  
Candace Andersen, District II Supervisor  
Mary N. Piepho, District III Supervisor  
Karen Mitchoff, District IV Supervisor  
Federal D. Glover, District V Supervisor

I hereby certify that this is a true and correct copy of an action taken and entered on the minutes of the Board of Supervisors on the date shown.

ATTESTED: November 1, 2016

David J. Twa, County Administrator and Clerk of the Board of Supervisors

By: Stephanie Mello, Deputy

Contact: Elaine Burres, 313-1717

cc:

AGENDA

ATTACHMENTS

Resolution No. 2016/607

MINUTES

ATTACHMENTS

Signed Resolution No. 607



*The Board of Supervisors of  
Contra Costa County, California*

In the matter of:

**Resolution No. 2016/607**

**Proclaiming November 2016 as Adoption Awareness Month in Contra Costa County.**

WHEREAS, the citizens of Contra Costa County recognize that all children need love, support, security, and a place to call home; and,  
WHEREAS, close to 70 adoptions have been finalized in Contra Costa County so far in 2016; and,  
WHEREAS, adoption was the permanency plan for 133 children in 2015 in Contra Costa County, including 73 who were adopted by a former foster parent, 53 who were adopted by family members, and 7 who were adopted by non-relatives; and,  
WHEREAS, these children need extra patience and support to help them overcome previous hardships, obtain stable home environments, or receive placements as part of a sibling group; and,  
WHEREAS, many of these children have special needs related to physical, mental or emotional disabilities and need the support that adoptive families can provide; and,  
WHEREAS, there are families able and willing to adopt children who have a range of needs; and,  
WHEREAS, adoption of children by family members encourages increased stability, higher levels of permanency, more likelihood of staying connected to siblings, greater preservation of cultural identity, and positive behavioral and mental outcomes due to placements with relative caregivers; and,  
WHEREAS, the many children in our local foster care program need and deserve the security and nurturing of permanent families, whether they are related or not; and,  
WHEREAS, Children & Family Services in Contra Costa County offers concurrent planning enabling the placement of children in a potential adoptive home while working with the birth family to help overcome challenges; and,  
WHEREAS, concurrent caregivers are foster parents and prospective adoptive parents at the same time who provide love and stability to children by reducing the number of placements and providing permanency while assisting in reunification efforts; and,  
WHEREAS, disability, low income, or unmarried status does not preclude the right to adopt; and,  
WHEREAS, adoptive parents and families who have adopted children require and deserve community and public agency support.

Now, Therefore, Be It Resolved: The Contra Costa County Board of Supervisors hereby proclaims November 2016 as Adoption Awareness Month in Contra Costa County.

\_\_\_\_\_  
**CANDACE ANDERSEN**

Chair,  
District II Supervisor

\_\_\_\_\_  
**JOHN GIOIA**  
District I Supervisor

\_\_\_\_\_  
**MARY N. PIEPHO**  
District III Supervisor

\_\_\_\_\_  
**KAREN MITCHOFF**  
District IV Supervisor

\_\_\_\_\_  
**FEDERAL D. GLOVER**  
District V Supervisor

I hereby certify that this is a true and correct copy of an action taken and entered on the minutes of the Board of Supervisors on the date shown.

ATTESTED: November 1, 2016

David J. Twa,

By: \_\_\_\_\_, Deputy

# Board of Supervisors of Contra Costa County, California

IN THE MATTER OF PROCLAIMING NOVEMBER, 2016 AS  
"ADOPTION AWARENESS MONTH" IN CONTRA COSTA  
COUNTY

RESOLUTION NO. 2016/607

WHEREAS, the citizens of Contra Costa County recognize that all children need love, support, security, and a place to call home; and

WHEREAS, close to 70 adoptions have been finalized in Contra Costa County so far in 2016; and

WHEREAS, adoption was the permanency plan for 133 children in 2015 in Contra Costa County, including 73 who were adopted by a former foster parent, 53 who were adopted by family members, and 7 who were adopted by non-relatives; and

WHEREAS, these children need extra patience and support to help them overcome previous hardships, obtain stable home environments, or receive placements as part of a sibling group; and

WHEREAS, many of these children have special needs related to physical, mental or emotional disabilities and need the support that adoptive families can provide; and

WHEREAS, there are families able and willing to adopt children who have a range of needs; and

WHEREAS, adoption of children by family members encourages increased stability, higher levels of permanency, more likelihood of staying connected to siblings, greater preservation of cultural identity, and positive behavioral and mental outcomes due to placements with relative caregivers; and

WHEREAS, the many children in our local foster care program need and deserve the security and nurturing of permanent families, whether they are related or not; and

WHEREAS, Children & Family Services in Contra Costa County offers concurrent planning enabling the placement of children in a potential adoptive home while working with the birth family to help overcome challenges; and

WHEREAS, concurrent caregivers are foster parents and prospective adoptive parents at the same time who provide love and stability to children by reducing the number of placements and providing permanency while assisting in reunification efforts; and

WHEREAS, disability, low income, or unmarried status does not preclude the right to adopt; and

WHEREAS, adoptive parents and families who have adopted children require and deserve community and public agency support.

NOW, THEREFORE, BE IT RESOLVED that the Board of Supervisors of Contra Costa County does hereby proclaim November, 2016 as

## Adoption Awareness Month in Contra Costa County.

PASSED by a unanimous vote of the Board of Supervisors members present this 1<sup>st</sup> day of November, 2016.

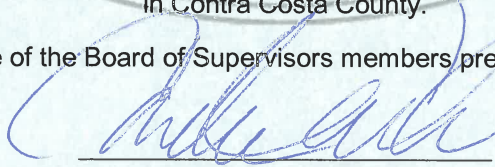

**CANDACE ANDERSEN**  
Chair,  
District II Supervisor

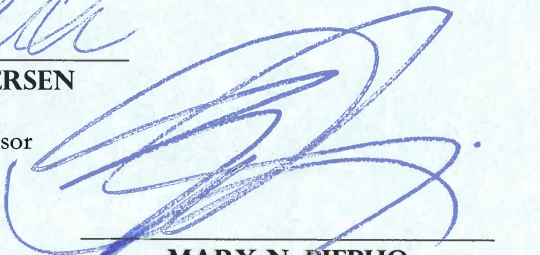

**MARY N. PIEPHO**  
District III Supervisor

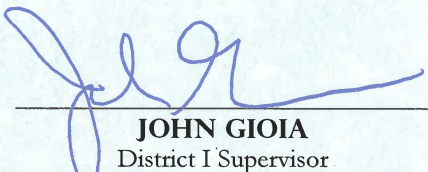

**JOHN GIOIA**  
District I Supervisor



**KAREN MITCHOFF**  
District IV Supervisor

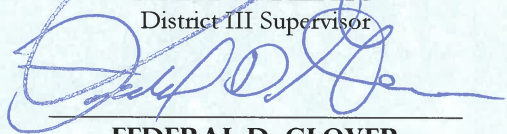

**FEDERAL D. GLOVER**  
District V Supervisor



I hereby certify that this is a true and correct copy of an action taken and entered on the minutes of the Board of Supervisors on the date shown:

ATTESTED: November 1, 2016

DAVID TWA, Clerk of the Board of Supervisors and County Administrator

By Stephanie Melto, Deputy



Contra  
Costa  
County

To: Board of Supervisors  
From: William Walker, M.D., Health Services Director  
Date: November 1, 2016

Subject: CAER 2016 Shelter-in-Place Education Day

---

**RECOMMENDATION(S):**

Proclaim November 2, 2016 as the Contra Costa County Shelter-in-Place Education Day.

**BACKGROUND:**

Contra Costa County Community Awareness and Emergency Response Group, Inc. has worked with schools and day care facilities for the last nine years on sheltering in place when there is a hazardous material release that could impact them. This protective action is the best immediate action that a person can take to protect them against exposure to hazardous materials that could occur from an accidental release or spill. Attached find the proclamation and a flyer announcing November 2, 2016 as Shelter-in-Place Education Day.

---

APPROVE

OTHER

RECOMMENDATION OF CNTY  
ADMINISTRATOR

RECOMMENDATION OF BOARD  
COMMITTEE

---

Action of Board On: **11/01/2016**  APPROVED AS  
RECOMMENDED

OTHER

Clerks Notes:

**VOTE OF SUPERVISORS**

AYE: John Gioia, District I Supervisor  
Candace Andersen, District II  
Supervisor  
Mary N. Piepho, District III  
Supervisor  
Karen Mitchoff, District IV  
Supervisor  
Federal D. Glover, District V  
Supervisor

I hereby certify that this is a true and correct copy of an action taken and entered on the minutes of the Board of Supervisors on the date shown.

ATTESTED: November 1, 2016

David J. Twa, County Administrator and Clerk of the Board of Supervisors

By: Stephanie Mello, Deputy

Contact: Randy Sawyer, 335-3210

cc: Tasha Scott, Cho Nai Cheung, Marcy Wilhelm

AGENDA ATTACHMENTS

Resolution No. 2016/617

Factsheet Drill

MINUTES ATTACHMENTS

Signed Resolution No.

2016/617

*The Board of Supervisors of  
Contra Costa County, California*

In the matter of:

**Resolution No. 2016/617**

**Proclaiming November 2, 2016 as Shelter-in-Place Education Day in Contra Costa County.**

Whereas public and private schools throughout Contra Costa County will be participating in the Shelter-in-Place Drill on November 2nd; and

Whereas Contra Costa Community Awareness Emergency Response Group – CAER – is sponsoring the 15th Annual Shelter-in-Place Drill and assisting schools with their emergency preparedness; and

Whereas emergency response agencies including fire, sheriff and health officials all recommend Shelter-in-Place as the immediate action to take in case of a hazardous release; and

Whereas the Shelter-in-Place Drill increases public awareness about Shelter-in-Place as a protective action and gives students and teachers practice in implementing this important procedure; and

Whereas the County Office of Education has endorsed the Shelter-in-Place Drill and encouraged all sites to participate.

Now, Therefore, Be It Resolved that the Contra Costa County Board of Supervisors recognizes the importance of preparing for emergencies and encourages participation in the Contra Costa CAER Group’s public education efforts. In support of the parents, teachers, students and staff that will be participating with hundreds of other schools in the Shelter-in-Place Drill, we proclaim November 2, 2016 as “Shelter-in-Place Education Day”.

\_\_\_\_\_  
**CANDACE ANDERSEN**

Chair,  
District II Supervisor

\_\_\_\_\_  
**JOHN GIOIA**  
District I Supervisor

\_\_\_\_\_  
**MARY N. PIEPHO**  
District III Supervisor

\_\_\_\_\_  
**KAREN MITCHOFF**  
District IV Supervisor

\_\_\_\_\_  
**FEDERAL D. GLOVER**  
District V Supervisor

I hereby certify that this is a true and correct copy of an action taken and entered on the minutes of the Board of Supervisors on the date shown.

ATTESTED: November 1, 2016

David J. Twa,

By: \_\_\_\_\_, Deputy



## 2016 Shelter-in-Place Drill FACT SHEET

- The Shelter-in-Place drill will begin at 11:00 a.m. on November 2nd.

*Or, if necessary, you can change to a time better suited to your site.*



**Please note: If you do not normally hear the sound of the sirens on the first Wednesday of every month YOU WILL NOT HEAR THEM ON Nov.2<sup>nd</sup>** Sirens are only **one** of the ways a Shelter-in-Place alert is broadcast. In an actual emergency, other tools to alert the public would also be used, such as KCBS 740AM radio, e-mail notifications (visit [www.incident.com](http://www.incident.com) to sign up), scrolling messages on CCTV, weather radio alerts, and the TENS system (automated telephone calls).

- Each site will determine how complex they want the Shelter-in-Place drill to be at their own facility. The scope can range from a tabletop exercise with staff to a full-scale drill bringing everyone inside to Shelter-in-Place. Drill can be as long as you want it to be.
- The drill is being sponsored by Contra Costa County CAER (Community Awareness Emergency Response) Group. CAER is a non-profit organization with members from fire, law enforcement, health services, emergency services, plus community and industry representatives.
- All public and private schools and childcare centers are encouraged to participate. This is a chance to be part of a countywide exercise that will receive media coverage and promote further awareness about Shelter-in-Place training and procedures.
- Participating schools and childcare centers that return a “participation sheet” will have their names posted on the CAER Web site at [www.cococaer.org](http://www.cococaer.org).
- City Councils in the County are being asked to proclaim November 2<sup>nd</sup> as “Shelter-in-Place Education Day.” The County Board of Supervisors will also proclaim November 2<sup>nd</sup> as Shelter-in-Place Education Day.
- The Shelter-in-Place Drill is an annual event on the first Wednesday in November. Last year, approx. 200 sites participated and even more are expected to practice their Shelter-in-Place procedures this year. CAER sponsors the drill to promote emergency preparedness in our schools and childcare centers.

**Sponsored by CCC CAER Group, Inc.  
Community Awareness Emergency Response  
[www.cococaer.org](http://www.cococaer.org)**

# Board of Supervisors of Contra Costa County, California

IN THE MATTER OF PROCLAIMING NOVEMBER 2, 2016  
AS "SHELTER-IN-PLACE EDUCATION DAY" IN CONTRA  
COSTA COUNTY

RESOLUTION NO. 2016/617

WHEREAS, public and private schools throughout Contra Costa County will be participating in the Shelter-in-Place Drill on November 2nd; and

WHEREAS, Contra Costa Community Awareness Emergency Response Group – CAER – is sponsoring the 15th Annual Shelter-in-Place Drill and assisting schools with their emergency preparedness; and

WHEREAS, emergency response agencies including Fire, Sheriff and Health Officials all recommend Shelter-in-Place as the immediate action to take in case of a hazardous release; and

WHEREAS, the Shelter-in-Place Drill increases public awareness about Shelter-in-Place as a protective action and gives students and teachers practice in implementing this important procedure; and

WHEREAS, the County Office of Education has endorsed the Shelter-in-Place Drill and encouraged all sites to participate.

NOW, THEREFORE, BE IT RESOLVED that the Board of Supervisors of Contra Costa County does hereby recognize the importance of preparing for emergencies and encourages participation in the Contra Costa CAER Group's public education efforts and proclaim November 2, 2016 as

## Shelter-in-Place Education Day

in support of the parents, teachers, students and staff that will be participating with hundreds of other schools in the Shelter-in-Place Drill.

PASSED by a unanimous vote of the Board of Supervisors members present this 1<sup>st</sup> day of November, 2016.

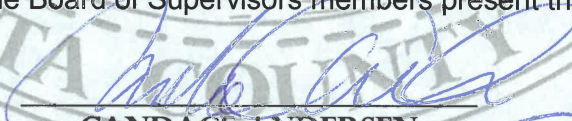

CANDACE ANDERSEN

Chair,  
District II Supervisor

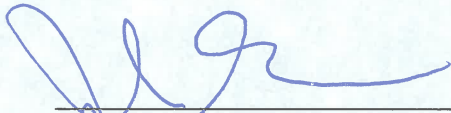

JOHN GIOIA  
District I Supervisor



KAREN MITCHOFF  
District IV Supervisor

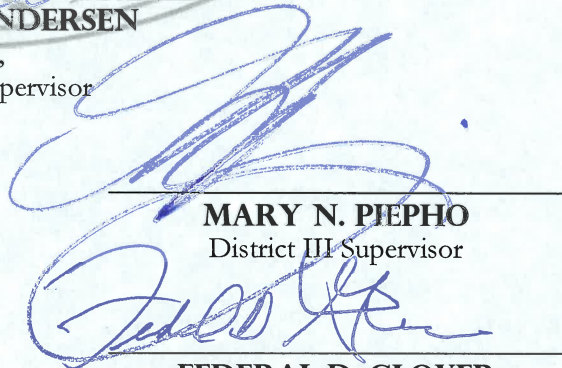

MARY N. PIEPHO  
District III Supervisor

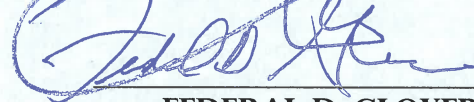

FEDERAL D. GLOVER  
District V Supervisor



I hereby certify that this is a true and correct copy of an action taken and entered on the minutes of the Board of Supervisors on the date shown:

ATTESTED: November 1, 2016

DAVID TWA, Clerk of the Board of Supervisors and County Administrator

By Stephanie Mello, Deputy



To: Board of Supervisors  
From: Dianne Dinsmore, Human Resources Director  
Date: November 1, 2016

Subject: ADOPT Ordinance No. 2016-20 amending Section 33-5.313 of the County Ordinance Code

---

**RECOMMENDATION(S):**

ADOPT Ordinance No. 2016-20 amending the County Ordinance Code to change the appointing authority of the exempt classification of Medical Director and to remove the exempt classifications of Ambulatory Care Chief Executive Officer, Contra Costa Health Plan Medical Director, and Mental Health Medical Director from the list of classifications excluded from the Merit System as requested by the Health Services Department.

**FISCAL IMPACT:**

There are no costs associated with this action.

**BACKGROUND:**

Contra Costa Health Services system of care has grown and continues to expand its services to accommodate the increase in the number of patients served throughout Contra Costa County. Further, expanded services are necessary in order to meet guidelines and regulations set forth by federal, state, and accreditation agencies. These services require effective and efficient medical care oversight and warrant the addition of two (2) Medical Director - Exempt positions within the Health Services Senior Management Executive Team.

The Medical Director-Exempt classification will be utilized in various

APPROVE

OTHER

RECOMMENDATION OF CNTY  
ADMINISTRATOR

RECOMMENDATION OF BOARD  
COMMITTEE

---

Action of Board On: **11/01/2016**

APPROVED AS  
RECOMMENDED

OTHER

Clerks Notes:

**VOTE OF SUPERVISORS**

AYE: John Gioia, District I Supervisor  
Candace Andersen, District II  
Supervisor  
Mary N. Piepho, District III Supervisor  
Karen Mitchoff, District IV Supervisor  
Federal D. Glover, District V Supervisor

I hereby certify that this is a true and correct copy of an action taken and entered on the minutes of the Board of Supervisors on the date shown.

ATTESTED: November 1, 2016

David J. Twa, County Administrator and Clerk of the Board of Supervisors

Contact: Dorette McCollum (925)  
957-5240

By: June McHuen, Deputy

cc: Dorette McCollum



BACKGROUND: (CONT'D)

areas of the health care system including Contra Costa Regional Medical Center and Health Centers, Contra Costa Health Plan, Behavioral Health, Emergency Medical Services, and Public Health. The primary responsibility is to plan, organize, implement and direct the professional medical standards, comprehensiveness and efficiency of the medical care component in the health care system. The Department has determined that the classifications of Contra Costa Health Plan Medical Director, Mental Health Medical Director and Ambulatory Care Chief Executive Officer, and their vacant positions no longer meet its operational needs. On October 25, 2016, the Board approved the introduction of Ordinance 2016-20, which proposed to amend the County Ordinance Code to change the appointing authority of the exempt classification of Medical Director from the Board to the Director of Health Services, to remove the classifications of Ambulatory Care Chief Executive Officer, Contra Costa Health Plan Medical Director, and Mental Health Medical Director from the list of classifications excluded from the merit system, to waive the reading, and fix November 1, 2016 for adoption.

The Department is therefore requesting that the Board adopt Ordinance No. 2016-20. Additionally, under Personnel Actions of this agenda, the Department is also requesting to abolish the exempt classifications of Contra Costa Health Plan Medical Director, Mental Health Medical Director and Ambulatory Care Chief Executive Officer, cancel their respective vacant position, and add two Medical Director - Exempt positions to meet medical care oversight needs in Health Services divisions.

CONSEQUENCE OF NEGATIVE ACTION:

Failure to obtain Board approval will hinder the Department's efforts to efficiently and effectively manage the expanded health services system of care, which may adversely impact patient care services.

ATTACHMENTS

Ordinance No. 2016-20

**ORDINANCE NO. 2016-20**

**(Change the Appointing Authority of the Exempt Classification of Medical Director and delete the exempt classifications of Ambulatory Care Chief Executive Officer, CCHP Medical Director and Mental Health Medical Director from the List of Classifications Excluded from the Merit System)**

The Contra Costa County Board of Supervisors ordains as follows (omitting the parenthetical footnotes from the official text of the enacted or amended provisions of the County Ordinance Code):

**SECTION I:** Section 33-5.313 of the County Ordinance Code is amended to change the appointing authority of the Medical Director-Exempt classification and to remove the classifications of Ambulatory Care Chief Executive Officer-Exempt, Contra Costa Health Plan Medical Director and Mental Health Medical Director-Exempt from the list of classifications excluded from the merit system:

33-5.313 - Health-medical.

- (a) Classifications appointed by the Board of Supervisors
  - (1) The director of health services is excluded and is appointed by the board.
  - (2) The county health officer (Health and Safety Code Section 101000) is excluded and is appointed by the board.
  - (3) The county physician (Health and Safety Code Section 1441) is excluded and is appointed by the board.
  - (4) The county (local) director of mental health services (Welfare and Institutions Code Section 5607, 9 Cal. Code of Regulations Sections 620 et seq.) is excluded and is appointed by the board.
- (b) General Executive and Administrative classifications
  - (1) The assistant to the health services director-exempt is excluded and is appointed by the director of health services.
  - (2) The assistant directors of health services are excluded and are appointed by the director of health services.
  - (3) The health services administrative officer is excluded and is appointed by the director of health services.
  - (4) The health services personnel officer-exempt is excluded and is appointed by the director of health services.
  - (5) The chief operations officer-exempt is excluded and is appointed by the director of health services.
  - (6) The emergency medical services director-exempt is excluded and is appointed by the director of health services.
  - (7) The medical directors are excluded and are appointed by the director of health services.
- (c) County Hospital and Clinics classifications
  - (1) The Contra Costa Regional Medical Center chief executive officer-exempt is excluded and is appointed by the director of health services.
  - (2) The chief medical officer-exempt is excluded and is appointed by the director of health services.

- (3) The residency director-exempt is excluded and is appointed by the director of health services.
  - (4) The chief quality officer-exempt is excluded and is appointed by the director of health services.
  - (5) The director of patient financial services is excluded and is appointed by the director of health services.
  - (6) The chief nursing officer-exempt is excluded and is appointed by the director of health services.
  - (7) Physicians and dentists serving the county (except those in the classifications of assistant health officer, and chief of community health services) are excluded and are appointed by the director of health services.
- (d) Contra Costa Health Plan (CCHP) classifications
- (1) The chief executive officer, Contra Costa Health Plan-exempt is excluded and is appointed by the director of health services.
  - (2) The deputy executive director, Contra Costa Health Plan-exempt is excluded and is appointed by the director of health services.
  - (3) The director of marketing, member services, and public relations-Contra Costa Health Plan is excluded and is appointed by the director of health services.
  - (4) The health plan services assistant-exempt is excluded and is appointed by the director of health services.
- (e) Information Technology classifications
- (1) The health services information technology director-exempt is excluded and is appointed by the director of health services.
  - (2) The assistant health services information technology director-project management-exempt is excluded and is appointed by the director of health services.
  - (3) The assistant health services information technology director-application development-exempt is excluded and is appointed by the director of health services.
  - (4) The assistant health services information technology director-customer support-exempt is excluded and is appointed by the director of health services.
  - (5) The assistant health services information technology director-infrastructure-exempt is excluded and is appointed by the director of health services.
  - (6) The assistant health services information technology director-information security-exempt is excluded and is appointed by the director of health services.
- (f) Environmental & Mental Health classifications
- (1) The mental health education liaison-exempt is excluded and is appointed by the director of health services.
  - (2) The director of environmental health services is excluded and is appointed by the director of health services.
  - (3) The director of hazardous materials programs-exempt is excluded

and is appointed by the director of health services.

(4) The executive assistant to the hazardous materials commission-exempt is excluded and is appointed by the director of health services.

(Ord. Nos. 2016-20 § 1, 2016-09 § 1, 2013-04 § 1, 2011-14 § 1, 2011-06 § 1, 2010-13 § 1, 2009-16 § 1, 2009-09 § 1, 2008-11 § 1, 2007-37 § 1, 2005-28 § 1, 2004-11 § 1, 2003-32 § 1, 99-23, 98-11 § 1, 98-5 § 1, 97-25 § 1, 97-13 § 1, 96-31 § 1, 93-3 § 1, 92-2 § 1, 90-124 § 1, 90-55, 86-97, 86-32, 85-50 § 2, 83-9, 1-70 § 2, 81-32 § I[5], 80-69 § 1, 80-34 § 1, 80-6, 79-29, 79-9 § 3: § 32-2.602 (7, 13, 16): prior code § 2413 (g, n, r): Ords. 69-81, 2030, 471: Bd. Sups. Resol. # 79/201).

**SECTION II: EFFECTIVE DATE.** This ordinance becomes effective 30 days after passage, and within 15 days of passage shall be published once with the names of the supervisors voting for and against it in the \_\_\_\_\_, a newspaper published in this County.

PASSED ON \_\_\_\_\_ by the following vote:

AYES:

NOES:

ABSENT:

ABSTAIN:

ATTEST: DAVID J. TWA, Clerk of the  
Board of Supervisors and County Administrator

By: \_\_\_\_\_  
Deputy

\_\_\_\_\_ Board Chair

[SEAL]

H:\Human Resources\Ordinance Code Changes\Ord re exclude Medical Dir & delete other HSD classes- Oct 2016.doc



**Contra  
Costa  
County**

To: Board of Supervisors  
From: William Walker, M.D., Health Services Director  
Date: November 1, 2016

Subject: Medical Staff Appointments and Reappointments – October 2016

---

**RECOMMENDATION(S):**

Approve the medical staff appointments and reappointments, additional privileges, department change request, medical staff advancement and application withdrawal as recommend by the Medical Staff Executive Committee, at their October 18, 2016 meeting, and by the Health Services Director.

**FISCAL IMPACT:**

Not applicable.

**BACKGROUND:**

The Joint Commission on Accreditation of Healthcare Organizations has requested that evidence of Board of Supervisors approval for each Medical Staff member will be placed in his or her Credentials File. The above recommendations for appointment/reappointment were reviewed by the Credentials Committee and approved by the Medical Executive Committee.

**CONSEQUENCE OF NEGATIVE ACTION:**

If this action is not approved, the Contra Costa Regional Medical and Contra Costa Health Centers' medical staff would not be appropriately credentialed and therefore would not be in compliance with the Joint Commission on Accreditation of Healthcare Organizations.

---

APPROVE

OTHER

RECOMMENDATION OF CNTY  
ADMINISTRATOR

RECOMMENDATION OF BOARD  
COMMITTEE

---

Action of Board On: **11/01/2016**  APPROVED AS  
RECOMMENDED

OTHER

Clerks Notes:

**VOTE OF SUPERVISORS**

AYE: John Gioia, District I Supervisor  
Candace Andersen, District II Supervisor  
Mary N. Piepho, District III Supervisor  
Karen Mitchoff, District IV Supervisor  
Federal D. Glover, District V Supervisor

I hereby certify that this is a true and correct copy of an action taken and entered on the minutes of the Board of Supervisors on the date shown.

ATTESTED: November 1, 2016

David J. Twa, County Administrator and Clerk of the Board of Supervisors

By: June McHuen, Deputy

Contact: Anna Roth, 925-370-5101

cc: Tasha Scott, Marcy Wilhelm, Sana Salman

CHILDREN'S IMPACT STATEMENT:

Not applicable.

ATTACHMENTS

October List

**A. New Medical Staff Members**

Aaron Besterman, MD	Psychiatry/Psychology
Autumn Broady, MD	OB/GYN
Asal Fathian, MD	OB/GYN
David Gurley, MD	Emergency Medicine
Jesse Le, MD	Surgery - Urology
Estelita Marquez-Floyd, MD	Psychiatry/Psychology
Mariposa McCall, MD	Psychiatry/Psychology
Francisca Niameh, Psy.D	Psychiatry/Psychology
Bimal Patel, MD	Internal Medicine
Jayalakshmi Ravindran, MD	Pediatrics
Enriquez Santiago, MD	Emergency Medicine
Stephen Seager, MD	Psychiatry/Psychology
Dave Velleman, Psy.D	Psychiatry/Psychology
Carlos Zapata, MD	Psychiatry/Psychology

**B. Request for Primary Department Change**

	<b>Department</b>	<b>Requesting</b>
Roobal Sekhon, DO	Psychiatry/Psychology	Internal Medicine

**C. Request for Additional Privileges**

	<b>Department</b>	<b>Privilege</b>
Megan Baker, MD	Psychiatry/Psychology	Outpatient upgrade C to U
Nikki Ha, NP	Pediatrics	Nexplanon
Aleea Maye, MD	Internal Medicine	Outpatient Psychiatric Care

**D. Advance to Non-Provisional**

Catherine Berg, NP	Family Medicine
Lawrence Chan, MD	Diagnostic Imaging
Maria Gallego, FNP	Family Medicine
Laura Hans, MD	Pediatrics
Anna Lazo, Psy.D	Psychiatry/Psychology
Tamara McBride, MD	Family Medicine
Joshua Perlroth, MD	Internal Medicine (infectious disease)
Tanuj Sidhartha, MD	Psychiatry/Psychology
Byron Young, MD	Psychiatry/Psychology
Monica Wooldridge, NP	Family Medicine
Karen Weiss, NP	Family Medicine

**E. Biennial Reappointments**

Mitchell Applegate, MD	Internal Medicine	A
Richard D. Baldwin, MD	Psychiatry/Psychology	A
Mark Borsody, MD	Internal Medicine (Neur)	C
Adam Buck, MD	Hospitalist	A
Peter Castillo, MD	OB/GYN	C
Lilian Chan, MD	Family Medicine	A
Alice Del Rosario, MD	Psychiatry/Psychology	C
Krista Farey, MD	Family Medicine	A
Daniel Forkin, MD	Psychiatry/Psychology	C

Oliver Graham, MD	Hospitalist	A
Olga Kelly, MD	Pediatrics	A
Michael Knoll, DDS	Dental	A
Pradeep Kumar, MD	Psychiatry/Psychology	A
Flynne Lewis, MD	Pediatrics	A
Vananh Nguyen, MD	Diagnostic Imaging	C
Greta Perez, MD	Family Medicine	A
Roobal Sekhon, DO	Psychiatry/Psychology	A
David Stone, MD	Internal Medicine (Neph)	A
Steven Tremain, MD	Administration	Admin
Patrice Yang, MD	Family Medicine	A

**F. Biennial Renew of Privileges**

Miguel Ayala, NP	Family Medicine
Ae Sil Cheun, NP	Family Medicine
Marcia Furtado, NP	Family Medicine

**G. Biennial Reappointment for Teleradiologist (VRAD)**

Mailan Cao, MD  
Joshua Morais, MD  
Saadet Atay-Rosenthal, MD

**H. Voluntary Application Withdrawal**

Ian Atkinson, MD	Hospitalist
Soliman Atai, MD	Emergency Medicine
Heidi Brown, MD	Emergency Medicine
Anthony Cheng, MD	Anesthesia
Shobha Sharma, DO	Internal Medicine

**I. Voluntary Resignations**

Jennifer Owen, MD  
Shyni Subash, MD





Contra  
Costa  
County

To: Board of Supervisors  
From: William Walker, M.D., Health Services Director  
Date: November 1, 2016

Subject: Reallocate the classification of Mental Health Clinical Specialist - Project on the Salary Schedule

---

**RECOMMENDATION(S):**

ADOPT Position Adjustment Resolution No. 21986 to reallocate the salary of the Mental Health Clinical Specialist-Project (VQS2) (represented) classification from salary plan and grade TC2 1362 (\$4,594 - \$6,820) to salary plan and grade (\$4,695 - \$6,970) in the Health Services Department.

**FISCAL IMPACT:**

Upon approval, this action has an annual cost of approximately \$2,649 with estimated pension costs of \$640 already included. (100% General Fund, budgeted)

**BACKGROUND:**

The Health Services Department is requesting to reallocate the salary plan and grade of the Mental Health Clinical Specialist – Project to the same salary plan and grade of the merit system classification of Mental Health Clinical Specialist. It has been determined that the salary plan and grade can be reallocated to the same plan and grade of the merit system classification of Mental Health Clinical Specialist.

---

APPROVE

OTHER

RECOMMENDATION OF CNTY  
ADMINISTRATOR

RECOMMENDATION OF BOARD  
COMMITTEE

---

Action of Board On: **11/01/2016**  APPROVED AS  
RECOMMENDED

OTHER

Clerks Notes:

**VOTE OF SUPERVISORS**

AYE: John Gioia, District I Supervisor  
Candace Andersen, District II  
Supervisor  
Mary N. Piepho, District III Supervisor  
Karen Mitchoff, District IV Supervisor  
Federal D. Glover, District V Supervisor

I hereby certify that this is a true and correct copy of an action taken and entered on the minutes of the Board of Supervisors on the date shown.

ATTESTED: November 1, 2016

David J. Twa, County Administrator and Clerk of the Board of Supervisors

Contact: Melissa Carofanello (925)  
957-5248

By: Chris Heck, Deputy

CONSEQUENCE OF NEGATIVE ACTION:

If this action is not approved, the department will not be able to compensate employees occupying positions in the Mental Health Clinical Specialist - Project classification at the same salary level as non-Project classes.

CHILDREN'S IMPACT STATEMENT:

AGENDA ATTACHMENTS

P300 No. 21986 HSD

MINUTES ATTACHMENTS

P300 #21986 signed

**POSITION ADJUSTMENT REQUEST**

NO. 21986  
DATE 8/24/2016

Department HEALTH SERVICES Department No./  
Budget Unit No. 0467 Org No. 5899 Agency No. A18  
Action Requested: Reallocate the salary of Mental Health Clinical Specialist-Project (VQS2) (represented) from Salary Plan and Grade TC2 1362 (\$4,594 - \$6,820) to (\$4,695 - \$6,970) in the Health Services Department.

Proposed Effective Date: 11/1/2016

Classification Questionnaire attached: Yes  No  / Cost is within Department's budget: Yes  No

Total One-Time Costs (non-salary) associated with request: \$0.00

Estimated total cost adjustment (salary / benefits / one time):

Total annual cost \$2,649.18 Net County Cost \$2,649.18  
Total this FY \$1,766.12 N.C.C. this FY \$1,766.12

SOURCE OF FUNDING TO OFFSET ADJUSTMENT 100% General Fund

Department must initiate necessary adjustment and submit to CAO.  
Use additional sheet for further explanations or comments.

Melissa Carofanello

\_\_\_\_\_  
(for) Department Head

REVIEWED BY CAO AND RELEASED TO HUMAN RESOURCES DEPARTMENT

Enid Mendoza

10/26/2016

\_\_\_\_\_  
Deputy County Administrator

\_\_\_\_\_  
Date

HUMAN RESOURCES DEPARTMENT RECOMMENDATIONS

DATE 10/26/2016

Reallocate the salary of the Mental Health Clinical Specialist-Project (VQS2) (represented) classification from salary plan and grade TC2 1362 (\$4,594 - \$6,820) to salary plan and grade (\$4,695 - \$6,970)

Amend Resolution 71/17 establishing positions and resolutions allocating classes to the Basic / Exempt salary schedule.

Effective:  Day following Board Action.  
 \_\_\_\_\_(Date)

Gladys Scott Reid

10/26/2016

\_\_\_\_\_  
(for) Director of Human Resources

\_\_\_\_\_  
Date

COUNTY ADMINISTRATOR RECOMMENDATION:

DATE

10/26/2016

Approve Recommendation of Director of Human Resources  
 Disapprove Recommendation of Director of Human Resources  
 Other: \_\_\_\_\_

Enid Mendoza

\_\_\_\_\_  
(for) County Administrator

BOARD OF SUPERVISORS ACTION:

Adjustment is APPROVED  DISAPPROVED

David J. Twa, Clerk of the Board of Supervisors  
and County Administrator

DATE \_\_\_\_\_

BY \_\_\_\_\_

APPROVAL OF THIS ADJUSTMENT CONSTITUTES A PERSONNEL / SALARY RESOLUTION AMENDMENT

POSITION ADJUSTMENT ACTION TO BE COMPLETED BY HUMAN RESOURCES DEPARTMENT FOLLOWING BOARD ACTION

Adjust class(es) / position(s) as follows:

## REQUEST FOR PROJECT POSITIONS

Department \_\_\_\_\_

Date 10/27/2016

No. \_\_\_\_\_

1. Project Positions Requested:
  
2. Explain Specific Duties of Position(s)
  
3. Name / Purpose of Project and Funding Source (do not use acronyms i.e. SB40 Project or SDSS Funds)
  
4. Duration of the Project:      Start Date \_\_\_\_\_      End Date \_\_\_\_\_  
Is funding for a specified period of time (i.e. 2 years) or on a year-to-year basis? Please explain.
  
5. Project Annual Cost
  - a. Salary & Benefits Costs: \_\_\_\_\_
  - b. Support Costs: \_\_\_\_\_  
(services, supplies, equipment, etc.)
  - c. Less revenue or expenditure: \_\_\_\_\_
  - d. Net cost to General or other fund: \_\_\_\_\_
  
6. Briefly explain the consequences of not filling the project position(s) in terms of:
  - a. potential future costs
  - b. legal implications
  - c. financial implications
  - d. political implications
  - e. organizational implications
  
7. Briefly describe the alternative approaches to delivering the services which you have considered. Indicate why these alternatives were not chosen.
  
8. Departments requesting new project positions must submit an updated cost benefit analysis of each project position at the halfway point of the project duration. This report is to be submitted to the Human Resources Department, which will forward the report to the Board of Supervisors. Indicate the date that your cost / benefit analysis will be submitted
  
9. How will the project position(s) be filled?
  - a. Competitive examination(s)
  - b. Existing employment list(s) Which one(s)? \_\_\_\_\_
  - c. Direct appointment of:
    1. Merit System employee who will be placed on leave from current job
    2. Non-County employee

Provide a justification if filling position(s) by C1 or C2

USE ADDITIONAL PAPER IF NECESSARY

0.12

### POSITION ADJUSTMENT REQUEST

NO. 21986  
DATE 8/24/2016

Department HEALTH SERVICES

Department No./  
Budget Unit No. 0467 Org No. 5899 Agency No. A18

Action Requested: Reallocate the salary of Mental Health Clinical Specialist-Project (VQS2) (represented) from Salary Plan and Grade TC2 1362 (\$4,594 - \$6,820) to (\$4,695 - \$6,970) in the Health Services Department.

Proposed Effective Date: 11/1/2016

Classification Questionnaire attached: Yes  No  / Cost is within Department's budget: Yes  No

Total One-Time Costs (non-salary) associated with request: \$0.00

Estimated total cost adjustment (salary / benefits / one time):

Total annual cost	<u>\$2,649.18</u>	Net County Cost	<u>\$2,649.18</u>
Total this FY	<u>\$1,766.12</u>	N.C.C. this FY	<u>\$1,766.12</u>

SOURCE OF FUNDING TO OFFSET ADJUSTMENT 100% General Fund

Department must initiate necessary adjustment and submit to CAO.  
Use additional sheet for further explanations or comments.

Melissa Carofanello

(for) Department Head

REVIEWED BY CAO AND RELEASED TO HUMAN RESOURCES DEPARTMENT

Enid Mendoza

10/26/2016

Deputy County Administrator

Date

HUMAN RESOURCES DEPARTMENT RECOMMENDATIONS

DATE 10/26/2016

Reallocate the salary of the Mental Health Clinical Specialist-Project (VQS2) (represented) classification from salary plan and grade TC2 1362 (\$4,594 - \$6,820) to salary plan and grade (\$4,695 - \$6,970)

Amend Resolution 71/17 establishing positions and resolutions allocating classes to the Basic / Exempt salary schedule.

Effective:  Day following Board Action.

\_\_\_\_\_(Date)

Gladys Scott Reid

10/26/2016

(for) Director of Human Resources

Date

COUNTY ADMINISTRATOR RECOMMENDATION:

DATE

10/26/2016

- Approve Recommendation of Director of Human Resources
- Disapprove Recommendation of Director of Human Resources
- Other: \_\_\_\_\_

Enid Mendoza

(for) County Administrator

BOARD OF SUPERVISORS ACTION:

Adjustment is APPROVED  DISAPPROVED

David J. Twa, Clerk of the Board of Supervisors  
and County Administrator

DATE 11-1-16

BY Chris Heck

APPROVAL OF THIS ADJUSTMENT CONSTITUTES A PERSONNEL / SALARY RESOLUTION AMENDMENT

POSITION ADJUSTMENT ACTION TO BE COMPLETED BY HUMAN RESOURCES DEPARTMENT FOLLOWING BOARD ACTION

Adjust class(es) / position(s) as follows:



Contra  
Costa  
County

To: Board of Supervisors  
From: William Walker, M.D., Health Services Director  
Date: November 1, 2016

Subject: Abolish three classifications, cancel three positions, and add two positions in the Health Services Department

**RECOMMENDATION(S):**

ADOPT Position Adjustment Resolution No. 21979 to:

- Effective December 1, 2016, abolish the classifications of Contra Costa Health Plan Medical Director-Exempt (VPD4) and Mental Health Medical Director-Exempt (VPD1) at salary plan and grade B85-2643 (\$15,858) and cancel their respective vacant positions #9979 and #13822; and abolish the classification of Ambulatory Care Chief Executive Officer - Exempt (VAB1) at salary plan grade and level B85 2614 (\$15,408) and cancel vacant position #13890; and
- Effective November 2, 2016 add two Medical Director-Exempt (VCA2) positions at salary plan and grade B85 2645 (\$25,913) in the Health Services Department.

**FISCAL IMPACT:**

Upon approval of all actions, the total increased salary and benefit costs are approximately \$112,835, which includes estimated pension costs of \$51,594. The department has offset most of the costs with the elimination of three exempt classifications and their respective three positions. Additionally, the Medical Director - Exempt position for mental health will allow the department to eliminate a contract for mental health medical director services, which will offset the additional costs to mental health. Increased costs for CCHP will be funded 100% by CCHP Enterprise Fund II monies.

<input checked="" type="checkbox"/> APPROVE	<input type="checkbox"/> OTHER
<input checked="" type="checkbox"/> RECOMMENDATION OF CNTY ADMINISTRATOR	<input type="checkbox"/> RECOMMENDATION OF BOARD COMMITTEE

Action of Board On: **11/01/2016**  APPROVED AS RECOMMENDED  OTHER

Clerks Notes:

**VOTE OF SUPERVISORS**

AYE: John Gioia, District I Supervisor  
 Candace Andersen, District II Supervisor  
 Mary N. Piepho, District III Supervisor  
 Karen Mitchoff, District IV Supervisor  
 Federal D. Glover, District V Supervisor

I hereby certify that this is a true and correct copy of an action taken and entered on the minutes of the Board of Supervisors on the date shown.

ATTESTED: November 1, 2016  
 David J. Twa, County Administrator and Clerk of the Board of Supervisors

Contact: Jo-Anne Linares, (925) 957-5240

By: Chris Heck, Deputy

### BACKGROUND:

Contra Costa Health Services system of care has grown and continues to expand its services to accommodate the increase in the number of patients served throughout Contra Costa County. Further, expanded services are necessary in order to meet guidelines and regulations set forth by federal, state, and accreditation agencies. These services require effective and efficient medical care oversight and warrant the addition of two Medical Director - Exempt positions within the Health Services Department that will also serve on the Senior Management Executive Team. The Medical Director-Exempt classification will be utilized in various areas of the health care system including Contra Costa Regional Medical Center and Health Centers, Mental Health, Contra Costa Health Plan, Emergency Medical Services and Public Health. The primary responsibility is to plan, organize, implement and direct the professional medical standards, comprehensiveness and efficiency of the medical care component in the health care system.

With the addition of the Medical Director - Exempt positions, the Department has determined that the classifications of Contra Costa Health Plan Medical Director, Mental Health Medical Director, and Ambulatory Care Chief Executive Officer and their vacant positions no longer meet operational needs.

### CONSEQUENCE OF NEGATIVE ACTION:

Failure to obtain Board approval will hinder the Department's efforts to efficiently and effectively manage the expanded health services system of care, which may adversely impact patient care services.

### CHILDREN'S IMPACT STATEMENT:

Not applicable.

### AGENDA ATTACHMENTS

P300 No. 21979 HSD

### MINUTES ATTACHMENTS

P300 #21979 signed

**POSITION ADJUSTMENT REQUEST**

NO. 21979  
DATE 9/22/2016

Department Health Services Department No./ Budget Unit No. 0540 Org No. 6549 Agency No. A18

Action Requested: Effective 12/1/16: Abolish the classifications of CCHP Medical Director-Exempt (VPD4) and MH Medical Director-Exempt (VPD1), and cancel their respective vacant positions #9979 and #13622; and Abolish the classification of Ambulatory Care Chief Executive Officer (VAB1), and cancel position #13890. Effective 11/2/16: add two full-time Medical Director-Exempt (VCA2) positions in the Health Services Department.

Proposed Effective Date: See Action

Classification Questionnaire attached: Yes  No  / Cost is within Department's budget: Yes  No

Total One-Time Costs (non-salary) associated with request: \$0.00

Estimated total cost adjustment (salary / benefits / one time):

Total annual cost \$112,835.31 Net County Cost \$0.00  
Total this FY \$75,223.54 N.C.C. this FY \_\_\_\_\_

SOURCE OF FUNDING TO OFFSET ADJUSTMENT offset by cancellation of two positions and contracts

Department must initiate necessary adjustment and submit to CAO.  
Use additional sheet for further explanations or comments.

Jo-Anne Linares

\_\_\_\_\_  
(for) Department Head

REVIEWED BY CAO AND RELEASED TO HUMAN RESOURCES DEPARTMENT

Enid Mendoza

10/21/2016

\_\_\_\_\_  
Deputy County Administrator

\_\_\_\_\_  
Date

HUMAN RESOURCES DEPARTMENT RECOMMENDATIONS

DATE 10/26/2016

Effective December 1, 2016, abolish the classifications of Contra Costa Health Plan Medical Director-Exempt (VPD4) and Mental Health Medical Director-Exempt (VPD1) and cancel their respective vacant positions #9979 and #13822; and abolish the classification of Ambulatory Care Chief Executive Officer - Exempt (VAB1) and cancel position #13890; Effective November 2, 2016 add two Medical Director-Exempt (VCA2) positions

Amend Resolution 71/17 establishing positions and resolutions allocating classes to the Basic / Exempt salary schedule.

Effective:  Day following Board Action.

see action(Date)

Gladys Scott Reid

10/26/2016

\_\_\_\_\_  
(for) Director of Human Resources

\_\_\_\_\_  
Date

COUNTY ADMINISTRATOR RECOMMENDATION:

DATE

10/26/2016

Approve Recommendation of Director of Human Resources

Disapprove Recommendation of Director of Human Resources

Other: \_\_\_\_\_

Enid Mendoza

\_\_\_\_\_  
(for) County Administrator

BOARD OF SUPERVISORS ACTION:

Adjustment is APPROVED  DISAPPROVED

David J. Twa, Clerk of the Board of Supervisors  
and County Administrator

DATE \_\_\_\_\_

BY \_\_\_\_\_

APPROVAL OF THIS ADJUSTMENT CONSTITUTES A PERSONNEL / SALARY RESOLUTION AMENDMENT

POSITION ADJUSTMENT ACTION TO BE COMPLETED BY HUMAN RESOURCES DEPARTMENT FOLLOWING BOARD ACTION

Adjust class(es) / position(s) as follows:



## REQUEST FOR PROJECT POSITIONS

Department \_\_\_\_\_

Date 10/26/2016

No. xxxxxx

1. Project Positions Requested:
  
2. Explain Specific Duties of Position(s)
  
3. Name / Purpose of Project and Funding Source (do not use acronyms i.e. SB40 Project or SDSS Funds)
  
4. Duration of the Project: Start Date \_\_\_\_\_ End Date \_\_\_\_\_  
Is funding for a specified period of time (i.e. 2 years) or on a year-to-year basis? Please explain.
  
5. Project Annual Cost
  - a. Salary & Benefits Costs: \_\_\_\_\_
  - b. Support Costs: \_\_\_\_\_  
(services, supplies, equipment, etc.)
  - c. Less revenue or expenditure: \_\_\_\_\_
  - d. Net cost to General or other fund: \_\_\_\_\_
  
6. Briefly explain the consequences of not filling the project position(s) in terms of:
  - a. potential future costs
  - b. legal implications
  - c. financial implications
  - d. political implications
  - e. organizational implications
  
7. Briefly describe the alternative approaches to delivering the services which you have considered. Indicate why these alternatives were not chosen.
  
8. Departments requesting new project positions must submit an updated cost benefit analysis of each project position at the halfway point of the project duration. This report is to be submitted to the Human Resources Department, which will forward the report to the Board of Supervisors. Indicate the date that your cost / benefit analysis will be submitted
  
9. How will the project position(s) be filled?
  - a. Competitive examination(s)
  - b. Existing employment list(s) Which one(s)? \_\_\_\_\_
  - c. Direct appointment of:
    1. Merit System employee who will be placed on leave from current job
    2. Non-County employee

Provide a justification if filling position(s) by C1 or C2

USE ADDITIONAL PAPER IF NECESSARY

POSITION ADJUSTMENT REQUEST

NO. 21979  
DATE 9/22/2016

Department Health Services Department No./  
Budget Unit No. 0540 Org No. 6549 Agency No. A18

Action Requested: Effective 12/1/16: Abolish the classifications of CCHP Medical Director-Exempt (VPD4) and MH Medical Director-Exempt (VPD1), and cancel their respective vacant positions #9979 and #13622; and Abolish the classification of Ambulatory Care Chief Executive Officer (VAB1), and cancel position #13890. Effective 11/2/16: add two full-time Medical Director-Exempt (VCA2) positions in the Health Services Department.

Proposed Effective Date: See Action

Classification Questionnaire attached: Yes  No  / Cost is within Department's budget: Yes  No

Total One-Time Costs (non-salary) associated with request: \$0.00

Estimated total cost adjustment (salary / benefits / one time):

Total annual cost \$112,835.31 Net County Cost \$0.00  
Total this FY \$75,223.54 N.C.C. this FY \_\_\_\_\_

SOURCE OF FUNDING TO OFFSET ADJUSTMENT offset by cancellation of two positions and contracts

Department must initiate necessary adjustment and submit to CAO.  
Use additional sheet for further explanations or comments.

Jo-Anne Linares

\_\_\_\_\_  
(for) Department Head

REVIEWED BY CAO AND RELEASED TO HUMAN RESOURCES DEPARTMENT

Enid Mendoza

10/21/2016

\_\_\_\_\_  
Deputy County Administrator

\_\_\_\_\_  
Date

HUMAN RESOURCES DEPARTMENT RECOMMENDATIONS

DATE 10/26/2016

Effective December 1, 2016, abolish the classifications of Contra Costa Health Plan Medical Director-Exempt (VPD4) and Mental Health Medical Director-Exempt (VPD1) and cancel their respective vacant positions #9979 and #13822; and abolish the classification of Ambulatory Care Chief Executive Officer - Exempt (VAB1) and cancel position #13890; Effective November 2, 2016 add two Medical Director-Exempt (VCA2) positions

Amend Resolution 71/17 establishing positions and resolutions allocating classes to the Basic / Exempt salary schedule.

Effective:  Day following Board Action.  
 see action(Date)

Gladys Scott Reid

10/26/2016

\_\_\_\_\_  
(for) Director of Human Resources

\_\_\_\_\_  
Date

COUNTY ADMINISTRATOR RECOMMENDATION:

DATE

10/26/2016

- Approve Recommendation of Director of Human Resources
- Disapprove Recommendation of Director of Human Resources
- Other: \_\_\_\_\_

Enid Mendoza

\_\_\_\_\_  
(for) County Administrator

BOARD OF SUPERVISORS ACTION:

Adjustment is APPROVED  DISAPPROVED

David J. Twa, Clerk of the Board of Supervisors  
and County Administrator

DATE 11-1-16

BY Chris Heek

APPROVAL OF THIS ADJUSTMENT CONSTITUTES A PERSONNEL / SALARY RESOLUTION AMENDMENT

POSITION ADJUSTMENT ACTION TO BE COMPLETED BY HUMAN RESOURCES DEPARTMENT FOLLOWING BOARD ACTION

Adjust class(es) / position(s) as follows:



Contra  
Costa  
County

To: Board of Supervisors  
From: Melinda Cervantes, County Librarian  
Date: November 1, 2016

Subject: Add One (1) Administrative Aide Deep Class Position in the Library Department

---

**RECOMMENDATION(S):**

ADOPT Position Adjustment Resolution No. 21970 to add one (1) full-time Administrative Aide-Deep Class (AP7A) (unrepresented) position at salary plan and grade B85 0972 (\$3,031 - \$4,703) in the Library Department.

**FISCAL IMPACT:**

Upon approval, this action will result in an annual cost to the Library Fund of approximately \$67,428. There is no fiscal impact to the County General Fund. This position is funded in the Library budget.

**BACKGROUND:**

The Library has identified a need for an Administrative Aide Deep Class position to assist in preparing, monitoring, and processing key administrative functions that are para-professional and confidential in nature. Examples of duties include: research and analysis work involving Library operation and policy matters, preparing responses to all Public Records Act requests, providing select labor and personnel-related support, and carrying out on a day-to-day basis the business affairs of the Contra Costa County Library Commission. This position will report to the County Librarian.

**CONSEQUENCE OF NEGATIVE ACTION:**

If this position is not added, the Library will be less efficient in its administrative responses internally, as well as to the municipalities, the public and to its external partners such as Friends groups and the Contra Costa County Library Commission.

---

APPROVE  OTHER  
 RECOMMENDATION OF CNTY ADMINISTRATOR  RECOMMENDATION OF BOARD COMMITTEE

---

Action of Board On: **11/01/2016**  APPROVED AS RECOMMENDED  OTHER

Clerks Notes:

**VOTE OF SUPERVISORS**

AYE: John Gioia, District I Supervisor  
Candace Andersen, District II Supervisor  
Mary N. Piepho, District III Supervisor  
Karen Mitchoff, District IV Supervisor  
Federal D. Glover, District V Supervisor

I hereby certify that this is a true and correct copy of an action taken and entered on the minutes of the Board of Supervisors on the date shown.

ATTESTED: November 1, 2016  
David J. Twa, County Administrator and Clerk of the Board of Supervisors

Contact: Michelle McCauley, (925) 927-3202

By: Chris Heck, Deputy

AGENDA ATTACHMENTS

P300 21970 Add Admin Aide to Library

Dept

MINUTES ATTACHMENTS

P300 21970 signed

**POSITION ADJUSTMENT REQUEST**

NO. 21970  
DATE 9/26/2016

Department County Library Department No./  
Budget Unit No. 0620 Org No. 3702 Agency No. 85  
Action Requested: Add One Full-time 40/40 Administrative Aide Deep Class in the Library Department

Proposed Effective Date: 11/1/2016

Classification Questionnaire attached: Yes  No  / Cost is within Department's budget: Yes  No

Total One-Time Costs (non-salary) associated with request: \$0.00

Estimated total cost adjustment (salary / benefits / one time):

Total annual cost \$67,428.00 Net County Cost \$0.00  
Total this FY \$56,190.00 N.C.C. this FY \$0.00

SOURCE OF FUNDING TO OFFSET ADJUSTMENT Budgeted in the Library Fund

Department must initiate necessary adjustment and submit to CAO.  
Use additional sheet for further explanations or comments.

Theresa Speiker

\_\_\_\_\_  
(for) Department Head

REVIEWED BY CAO AND RELEASED TO HUMAN RESOURCES DEPARTMENT

BR for JE

10/7/2016

\_\_\_\_\_  
Deputy County Administrator

\_\_\_\_\_  
Date

HUMAN RESOURCES DEPARTMENT RECOMMENDATIONS

DATE 10/18/2016

Add one Administrative Aide - Deep Class (AP7A) (unrepresented) position at salary plan and grade B85 0972 (\$3,031 - \$4,703)

Amend Resolution 71/17 establishing positions and resolutions allocating classes to the Basic / Exempt salary schedule.

Effective:  Day following Board Action.  
 \_\_\_\_\_(Date)

Eldreai Ellis

10/18/2016

\_\_\_\_\_  
(for) Director of Human Resources

\_\_\_\_\_  
Date

COUNTY ADMINISTRATOR RECOMMENDATION:

DATE 10/25/2016

Approve Recommendation of Director of Human Resources  
 Disapprove Recommendation of Director of Human Resources  
 Other: \_\_\_\_\_

/s/ Julie DiMaggio Enea

\_\_\_\_\_  
(for) County Administrator

BOARD OF SUPERVISORS ACTION:

Adjustment is APPROVED  DISAPPROVED

David J. Twa, Clerk of the Board of Supervisors  
and County Administrator

DATE \_\_\_\_\_

BY \_\_\_\_\_

APPROVAL OF THIS ADJUSTMENT CONSTITUTES A PERSONNEL / SALARY RESOLUTION AMENDMENT

POSITION ADJUSTMENT ACTION TO BE COMPLETED BY HUMAN RESOURCES DEPARTMENT FOLLOWING BOARD ACTION

Adjust class(es) / position(s) as follows:

## REQUEST FOR PROJECT POSITIONS

Department \_\_\_\_\_

Date 10/25/2016

No. xxxxx

1. Project Positions Requested:
  
2. Explain Specific Duties of Position(s)
  
3. Name / Purpose of Project and Funding Source (do not use acronyms i.e. SB40 Project or SDSS Funds)
  
4. Duration of the Project:      Start Date \_\_\_\_\_      End Date \_\_\_\_\_  
Is funding for a specified period of time (i.e. 2 years) or on a year-to-year basis? Please explain.
  
5. Project Annual Cost
  - a. Salary & Benefits Costs: \_\_\_\_\_
  - b. Support Costs: \_\_\_\_\_  
(services, supplies, equipment, etc.)
  - c. Less revenue or expenditure: \_\_\_\_\_
  - d. Net cost to General or other fund: \_\_\_\_\_
  
6. Briefly explain the consequences of not filling the project position(s) in terms of:
  - a. potential future costs
  - b. legal implications
  - c. financial implications
  - d. political implications
  - e. organizational implications
  
7. Briefly describe the alternative approaches to delivering the services which you have considered. Indicate why these alternatives were not chosen.
  
8. Departments requesting new project positions must submit an updated cost benefit analysis of each project position at the halfway point of the project duration. This report is to be submitted to the Human Resources Department, which will forward the report to the Board of Supervisors. Indicate the date that your cost / benefit analysis will be submitted
  
9. How will the project position(s) be filled?
  - a. Competitive examination(s)
  - b. Existing employment list(s) Which one(s)? \_\_\_\_\_
  - c. Direct appointment of:
    1. Merit System employee who will be placed on leave from current job
    2. Non-County employee

Provide a justification if filling position(s) by C1 or C2

USE ADDITIONAL PAPER IF NECESSARY

### POSITION ADJUSTMENT REQUEST

NO. 21970  
DATE 9/26/2016

Department County Library

Department No./  
Budget Unit No. 0620 Org No. 3702 Agency No. 85

Action Requested: Add One Full-time 40/40 Administrative Aide Deep Class in the Library Department

Proposed Effective Date: 11/1/2016

Classification Questionnaire attached: Yes  No  / Cost is within Department's budget: Yes  No

Total One-Time Costs (non-salary) associated with request: \$0.00

Estimated total cost adjustment (salary / benefits / one time):

Total annual cost	<u>\$67,428.00</u>	Net County Cost	<u>\$0.00</u>
Total this FY	<u>\$56,190.00</u>	N.C.C. this FY	<u>\$0.00</u>

SOURCE OF FUNDING TO OFFSET ADJUSTMENT Budgeted in the Library Fund

Department must initiate necessary adjustment and submit to CAO.  
Use additional sheet for further explanations or comments.

Theresa Speiker  
\_\_\_\_\_  
(for) Department Head

REVIEWED BY CAO AND RELEASED TO HUMAN RESOURCES DEPARTMENT

BR for JE  
\_\_\_\_\_  
Deputy County Administrator  
10/7/2016  
\_\_\_\_\_  
Date

HUMAN RESOURCES DEPARTMENT RECOMMENDATIONS  
Add one Administrative Aide - Deep Class (AP7A) (unrepresented) position at salary plan and grade B85 0972 (\$3,031 - \$4,703)  
DATE 10/18/2016

Amend Resolution 71/17 establishing positions and resolutions allocating classes to the Basic / Exempt salary schedule.

Effective:  Day following Board Action.  
 \_\_\_\_\_ (Date)  
Eldreai Ellis  
\_\_\_\_\_  
(for) Director of Human Resources  
10/18/2016  
\_\_\_\_\_  
Date

COUNTY ADMINISTRATOR RECOMMENDATION: DATE 10/25/2016  
 Approve Recommendation of Director of Human Resources  
 Disapprove Recommendation of Director of Human Resources  
 Other: \_\_\_\_\_  
/s/ Julie DiMaggio Enea  
\_\_\_\_\_  
(for) County Administrator

BOARD OF SUPERVISORS ACTION: David J. Twa, Clerk of the Board of Supervisors and County Administrator  
Adjustment is APPROVED  DISAPPROVED   
DATE 11-1-16 BY Chris Hecke

APPROVAL OF THIS ADJUSTMENT CONSTITUTES A PERSONNEL / SALARY RESOLUTION AMENDMENT

POSITION ADJUSTMENT ACTION TO BE COMPLETED BY HUMAN RESOURCES DEPARTMENT FOLLOWING BOARD ACTION  
Adjust class(es) / position(s) as follows:



Contra  
Costa  
County

To: Board of Supervisors  
From: William Walker, M.D., Health Services  
Date: November 1, 2016

Subject: ADD two Permanent Intermittent Junior Radiological Technologist positions and two Permanent Intermittent Senior Radiological Technologist in Health

**RECOMMENDATION(S):**

ADOPT Position Adjustment Resolution No. 21984 to add two (2) permanent-intermittent Junior Radiological Technologist positions (V8WC) at salary level TCS-1556 (\$5,195-\$6,315) and add two (2) permanent-intermittent Senior Radiological Technologist (V8VA) positions at salary level TCS-1737 (\$6,215-\$7,554) in the Health Services Department. (Represented)

**FISCAL IMPACT:**

Upon approval, there is an annual cost of approximately \$195,135, which includes estimated pension costs of \$61,448. The funding source for these positions will be Hospital Enterprise Fund I.

**BACKGROUND:**

The Diagnostic Imaging (DI) unit at Contra Costa Regional Medical Center (CCRMC) is requesting to add permanent intermittent radiological technologists to perform imaging functions. The Diagnostic Imaging is responsible for assuring adequate and appropriate staffing coverage to perform imaging functions for CCRMC, Building 1, West County Health Center, Pittsburg Health Center, and at the Antioch Health Center. The radiological technologist areas of responsibilities include General Diagnostic Radiology, Magnetic Resonance Imaging (MRI),

APPROVE

OTHER

RECOMMENDATION OF CNTY  
ADMINISTRATOR

RECOMMENDATION OF BOARD  
COMMITTEE

Action of Board On: **11/01/2016**  APPROVED AS  
RECOMMENDED

OTHER

Clerks Notes:

**VOTE OF SUPERVISORS**

AYE: John Gioia, District I Supervisor  
Candace Andersen, District II  
Supervisor  
Mary N. Piepho, District III Supervisor  
Karen Mitchoff, District IV Supervisor  
Federal D. Glover, District V  
Supervisor

I hereby certify that this is a true and correct copy of an action taken and entered on the minutes of the Board of Supervisors on the date shown.

ATTESTED: November 1, 2016

David J. Twa, County Administrator and Clerk of the Board of Supervisors

By: Chris Heck, Deputy

Contact: Shelanda Adams,  
925-957-5263

cc:



BACKGROUND: (CONT'D)

Computerized Tomography (CT), Special Procedures, Mammography, etc. The requested positions can be assigned to any of the previous mentioned imaging modalities. Currently the availability of the DI pool of permanent intermittent technologists has decreased; leaving diagnostic imaging services short staffed which creates patient care delays. Additionally, inadequate staffing areas could lead to Joint Commission violations. Approval of this request will improve the department's ability to better staff the Diagnostic Imaging unit and decrease patient care delays.

CONSEQUENCE OF NEGATIVE ACTION:

If this action not approved, the department will not have adequate staffing which will impact patient's treatments by causing cancellations and delays in patient's exams.

CHILDREN'S IMPACT STATEMENT:

Not applicable.

AGENDA ATTACHMENTS

P300 No. 21984 HSD

MINUTES ATTACHMENTS

P300 #21984 signed

**POSITION ADJUSTMENT REQUEST**

NO. 21984  
DATE 10/10/2016

Department HEALTH SERVICES Department No./  
Budget Unit No. 0540 Org No. 6355 Agency No. A18  
Action Requested: Add two Permanent Intermittent Junior Radiological Technologist positions (V8WC) and two Permanent Intermittent Senior Radiological Technologist (V8VA) positions in the Health Services Department.

Proposed Effective Date: 11/2/2016

Classification Questionnaire attached: Yes  No  / Cost is within Department's budget: Yes  No

Total One-Time Costs (non-salary) associated with request: \$0.00

Estimated total cost adjustment (salary / benefits / one time):

Total annual cost \$195,134.80 Net County Cost \$0.00  
Total this FY \$162,612.33 N.C.C. this FY \$0.00

SOURCE OF FUNDING TO OFFSET ADJUSTMENT Hospital Enterprise Fund I

Department must initiate necessary adjustment and submit to CAO.  
Use additional sheet for further explanations or comments.

Shelanda Adams

\_\_\_\_\_  
(for) Department Head

REVIEWED BY CAO AND RELEASED TO HUMAN RESOURCES DEPARTMENT

Enid Mendoza

10/26/2016

\_\_\_\_\_  
Deputy County Administrator

\_\_\_\_\_  
Date

HUMAN RESOURCES DEPARTMENT RECOMMENDATIONS

DATE \_\_\_\_\_

Exempt from Human Resources review under delegated authority.

Amend Resolution 71/17 establishing positions and resolutions allocating classes to the Basic / Exempt salary schedule.

Effective:  Day following Board Action.  
 \_\_\_\_\_(Date)

\_\_\_\_\_  
(for) Director of Human Resources

\_\_\_\_\_  
Date

COUNTY ADMINISTRATOR RECOMMENDATION:

DATE

10/26/2016

- Approve Recommendation of Director of Human Resources
- Disapprove Recommendation of Director of Human Resources
- Other: Approve as recommended by the department.

Enid Mendoza

\_\_\_\_\_  
(for) County Administrator

BOARD OF SUPERVISORS ACTION:

David J. Twa, Clerk of the Board of Supervisors  
and County Administrator

Adjustment is APPROVED  DISAPPROVED

DATE \_\_\_\_\_

BY \_\_\_\_\_

APPROVAL OF THIS ADJUSTMENT CONSTITUTES A PERSONNEL / SALARY RESOLUTION AMENDMENT

POSITION ADJUSTMENT ACTION TO BE COMPLETED BY HUMAN RESOURCES DEPARTMENT FOLLOWING BOARD ACTION

Adjust class(es) / position(s) as follows:

## REQUEST FOR PROJECT POSITIONS

Department \_\_\_\_\_

Date 10/26/2016

No. \_\_\_\_\_

1. Project Positions Requested:
  
2. Explain Specific Duties of Position(s)
  
3. Name / Purpose of Project and Funding Source (do not use acronyms i.e. SB40 Project or SDSS Funds)
  
4. Duration of the Project:      Start Date \_\_\_\_\_      End Date \_\_\_\_\_  
Is funding for a specified period of time (i.e. 2 years) or on a year-to-year basis? Please explain.
  
5. Project Annual Cost
  - a. Salary & Benefits Costs: \_\_\_\_\_
  - b. Support Costs: \_\_\_\_\_  
(services, supplies, equipment, etc.)
  - c. Less revenue or expenditure: \_\_\_\_\_
  - d. Net cost to General or other fund: \_\_\_\_\_
  
6. Briefly explain the consequences of not filling the project position(s) in terms of:
  - a. potential future costs
  - b. legal implications
  - c. financial implications
  - d. political implications
  - e. organizational implications
  
7. Briefly describe the alternative approaches to delivering the services which you have considered. Indicate why these alternatives were not chosen.
  
8. Departments requesting new project positions must submit an updated cost benefit analysis of each project position at the halfway point of the project duration. This report is to be submitted to the Human Resources Department, which will forward the report to the Board of Supervisors. Indicate the date that your cost / benefit analysis will be submitted
  
9. How will the project position(s) be filled?
  - a. Competitive examination(s)
  - b. Existing employment list(s) Which one(s)? \_\_\_\_\_
  - c. Direct appointment of:
    1. Merit System employee who will be placed on leave from current job
    2. Non-County employee

Provide a justification if filling position(s) by C1 or C2

USE ADDITIONAL PAPER IF NECESSARY

C.15

POSITION ADJUSTMENT REQUEST

NO. 21984  
DATE 10/10/2016

Department HEALTH SERVICES Department No./  
Budget Unit No. 0540 Org No. 6355 Agency No. A18  
Action Requested: Add two Permanent Intermittent Junior Radiological Technologist positions (V8WC) and two Permanent Intermittent Senior Radiological Technologist (V8VA) positions in the Health Services Department.

Proposed Effective Date: 11/2/2016

Classification Questionnaire attached: Yes  No  / Cost is within Department's budget: Yes  No

Total One-Time Costs (non-salary) associated with request: \$0.00

Estimated total cost adjustment (salary / benefits / one time):

Total annual cost \$195,134.80 Net County Cost \$0.00  
Total this FY \$162,612.33 N.C.C. this FY \$0.00

SOURCE OF FUNDING TO OFFSET ADJUSTMENT Hospital Enterprise Fund I

Department must initiate necessary adjustment and submit to CAO.  
Use additional sheet for further explanations or comments.

Shelanda Adams  
\_\_\_\_\_  
(for) Department Head

REVIEWED BY CAO AND RELEASED TO HUMAN RESOURCES DEPARTMENT

Enid Mendoza 10/26/2016  
\_\_\_\_\_  
Deputy County Administrator Date

HUMAN RESOURCES DEPARTMENT RECOMMENDATIONS DATE \_\_\_\_\_  
Exempt from Human Resources review under delegated authority.

Amend Resolution 71/17 establishing positions and resolutions allocating classes to the Basic / Exempt salary schedule.

Effective:  Day following Board Action.  
 \_\_\_\_\_(Date)

\_\_\_\_\_  
(for) Director of Human Resources Date

COUNTY ADMINISTRATOR RECOMMENDATION: DATE 10/26/2016

- Approve Recommendation of Director of Human Resources
- Disapprove Recommendation of Director of Human Resources
- Other: Approve as recommended by the department.

Enid Mendoza  
\_\_\_\_\_  
(for) County Administrator

BOARD OF SUPERVISORS ACTION:  
Adjustment is APPROVED  DISAPPROVED

David J. Twa, Clerk of the Board of Supervisors  
and County Administrator

DATE 11-1-16

BY Chris Heck

APPROVAL OF THIS ADJUSTMENT CONSTITUTES A PERSONNEL / SALARY RESOLUTION AMENDMENT

POSITION ADJUSTMENT ACTION TO BE COMPLETED BY HUMAN RESOURCES DEPARTMENT FOLLOWING BOARD ACTION

Adjust class(es) / position(s) as follows:



Contra  
Costa  
County

To: Board of Supervisors  
From: William Walker, M.D., Health Services  
Date: November 1, 2016

Subject: Add 41 permanent full-time positions in varied classifications in the Health Services Department

---

**RECOMMENDATION(S):**

ADOPT Position Adjustment Resolution No. 21985 to add the following represented positions in the Health Services Department:

- One (1) 40/40 Exempt Medical Staff Physician (VPW9) at salary plan grade and level 1P5-2312 (\$11,052 - \$14,864)
- One (1) 40/40 Family Nurse Practitioner (VWSB) at salary plan grade and level L35-1873 (\$9,249 - \$11,242)
- One (1) 40/40 Public Health Nurse (VVXA) at salary plan grade and level LT2-1832 (\$7,663 - \$10,306)
- One (1) 40/40 Registered Nurse-Experienced Level (VWXD) at salary plan grade and level L3H-0400 (\$8,049 - \$8,972)
- One (1) 40/40 Licensed Vocational Nurse (VT7G) at salary plan grade and level TAX-1287 (\$4,129 - \$5,273)
- One (1) 40/40 Substance Abuse Counselor (VHVC) at salary plan grade and level TC5-1436 (\$4,797 - \$5,831)
- One (1) 40/40 Clerk-Senior Level (JWXC) at salary plan grade and level 3RX-1033 (\$3,210 - \$4,100)
- One (1) 40/40 Mental Health Clinical Specialist (VQSB) at salary plan grade and level TC2-1384 (\$4,694 - \$6,969)
- One (1) 40/40 Community Health Worker II (VKVB) at salary plan grade and level TC5-1043 (\$3,251 - \$3,951)
- 

---

<input checked="" type="checkbox"/> APPROVE	<input type="checkbox"/> OTHER
<input checked="" type="checkbox"/> RECOMMENDATION OF CNTY ADMINISTRATOR	<input type="checkbox"/> RECOMMENDATION OF BOARD COMMITTEE

---

Action of Board On: **11/01/2016**  APPROVED AS RECOMMENDED  OTHER

Clerks Notes:

**VOTE OF SUPERVISORS**

AYE: John Gioia, District I Supervisor  
Candace Andersen, District II Supervisor  
Mary N. Piepho, District III Supervisor  
Karen Mitchoff, District IV Supervisor  
Federal D. Glover, District V Supervisor

I hereby certify that this is a true and correct copy of an action taken and entered on the minutes of the Board of Supervisors on the date shown.

ATTESTED: November 1, 2016  
David J. Twa, County Administrator and Clerk of the Board of Supervisors

Contact: Jo-Anne Linares, (925) 957-5240

By: Chris Heck, Deputy

### RECOMMENDATION(S): (CONT'D)

One (1) 40/40 Community Health Worker Specialist (VKTA) at salary plan grade and level TC5-1103 (\$3,450 - \$4,193)

- One (1) 40/40 Medical Social Worker I (X4WB) at salary plan grade and level 255-1369 (\$4,317- \$5,247)
- One (1) 40/40 Health Services Planner/Evaluator-Level B (VCXD) at salary plan grade and level ZB2-1323 (\$4,419 - \$7,242)
- Two (2) 40/40 Health Services Administrator-Level C (VANH) at salary plan grade and level ZB2-1723 (\$6,567 - \$8,407)
- One (1) 40/40 Mental Health Program Manager (VQDC) at salary plan and grade level ZA5-1844 (\$7,186 - \$8,734)
- Three (3) 40/40 Mental Health Program Supervisor (VQHP) at salary plan and grade level ZA5-1749 (\$6,541 - \$7,950)
- One (1) 40/40 Director of Public Health Clinic Services (VVGS) at salary plan and grade level ZA5-2177 (\$9,992 - \$12,146)
- Four (4) 40/40 Public Health Nurse Program Manager (VWHL) at salary plan and grade level ZA5-1989 (\$8,902- \$10,821)
- Four (4) 40/40 Public Health Program Specialist I (VBSD) at salary plan and grade level ZA5-1602 (\$5,655 - \$6,873)
- One (1) 40/40 Public Health Program Specialist II (VBND) at salary plan and grade level ZA5-1711 (\$6,299 - \$7,657)
- One (1) 40/40 Substance Abuse Program Manager (VHGE) at salary plan and grade level ZA5-1750 (\$6,547 - \$7,958)
- Three (3) 40/40 Substance Abuse Program Supervisor (VHHB) at salary plan and grade level ZA5-1682 (\$6,121 - \$7,440)
- Two (2) 40/40 Health Services Information Systems Programmer/Analyst (LBTC) at salary plan and grade level ZB5-1787 (\$6,791 - \$9,101)
- One (1) 40/40 Health Services Information Technology Security Specialist (LBSD) at salary plan and grade level ZB5-1884 (\$7,476 - \$10,019)
- One (1) 40/40 Health Services Information Technology Project Manager (LBGF) at salary plan and grade level ZA5-1884 (\$7,476 - \$10,019)
- Four (4) 40/40 Health Services Systems Analyst II (LBVC) at salary plan and grade level ZB5-1784 (\$6,771 - \$9,074)
- One (1) 40/40 Database Administrator (LWSA) at salary plan and grade level ZB5-1834 (\$7,115 - \$9,535)

### FISCAL IMPACT:

Upon approval, this action has an annual cost of approximately \$6,605,676 with estimated pension costs of \$1,459,118 already included. The entire cost will be completely offset with Whole Person Care Pilot Program revenues, which will provide \$20 million net annually over a five-year period for the Department to identify high cost Medi-Cal utilizers that may benefit from the development and provision on low cost alternative services.

### BACKGROUND:

Contra Costa County Health Services is one of eighteen counties who has applied for and expects to receive \$20 million funding for a Whole Person Care (WPC) Pilot Program from the California Department of Health Care Services (DHCS). The Program provides integrated physical health, behavioral health, and social services in a patient-centered manner with the goals of improved health and well-being of a vulnerable population. It targets Medi-Cal patients who are high-risk, high-utilizers of high acuity medical services and/or across multiple delivery systems.

The Program will provide coordination of services through a three-pronged approach: 1) Integrated and Coordinated Data Systems, 2) Enhanced and Coordinated Case Management, and 3) a Sobering Center. It requires a robust staffing profile to meet the deliverables set forth by the DHCS and to deliver the team-based case management and care coordination services to the County's highest utilizing Medi-Cal population. The Department is requesting 41 positions in varied classifications including administrative and technical support, clinic providers, information technology and management staff to provide enhanced case management services in

order to address underlying social determinants of health that are leading to poor health outcomes.

Immediately following Board approval, the Department plans to start recruitment processes to fill the positions and orient staff as the program implementation date is set for July 1, 2017.

CONSEQUENCE OF NEGATIVE ACTION:

If this action is not approved, the Department will lose \$20 million funds for the Whole Person Care Pilot Program from the Department of Health Care Services.

CHILDREN'S IMPACT STATEMENT:

No impact.

AGENDA ATTACHMENTS

P300 No. 21985 HSD

P300 No. 21985 Attachment #1

MINUTES ATTACHMENTS

P300 #21985 signed

**POSITION ADJUSTMENT REQUEST**

NO. 21985  
DATE 10/19/2016

Department Health Services

Department No./  
Budget Unit No. 0450 Org No. 6377 Agency No. A18

Action Requested: Add 41 permanent full-time positions in varied classifications in the Health Services Department, as specified in Attachment No. 1.

Proposed Effective Date: 11/2/2016

Classification Questionnaire attached: Yes  No  / Cost is within Department's budget: Yes  No

Total One-Time Costs (non-salary) associated with request: \$0.00

Estimated total cost adjustment (salary / benefits / one time):

Total annual cost \$6,605,676.01 Net County Cost \$0.00

Total this FY \$3,302,828.00 N.C.C. this FY \$0.00

SOURCE OF FUNDING TO OFFSET ADJUSTMENT 100% offset with Whole Person Care Pilot Program

Department must initiate necessary adjustment and submit to CAO.  
Use additional sheet for further explanations or comments.

Jo-Anne Linares

\_\_\_\_\_  
(for) Department Head

REVIEWED BY CAO AND RELEASED TO HUMAN RESOURCES DEPARTMENT

Enid Mendoza

10/26/2016

\_\_\_\_\_  
Deputy County Administrator

\_\_\_\_\_  
Date

HUMAN RESOURCES DEPARTMENT RECOMMENDATIONS

DATE 10/26/2016

See Attachment No. 1

Amend Resolution 71/17 establishing positions and resolutions allocating classes to the Basic / Exempt salary schedule.

Effective:  Day following Board Action.

\_\_\_\_\_(Date)

Gladys Scott Reid

10/26/2016

\_\_\_\_\_  
(for) Director of Human Resources

\_\_\_\_\_  
Date

COUNTY ADMINISTRATOR RECOMMENDATION:

DATE

10/26/2016

Approve Recommendation of Director of Human Resources

Disapprove Recommendation of Director of Human Resources

Other: \_\_\_\_\_

Enid Mendoza

\_\_\_\_\_  
(for) County Administrator

BOARD OF SUPERVISORS ACTION:

Adjustment is APPROVED  DISAPPROVED

David J. Twa, Clerk of the Board of Supervisors  
and County Administrator

DATE \_\_\_\_\_

BY \_\_\_\_\_

APPROVAL OF THIS ADJUSTMENT CONSTITUTES A PERSONNEL / SALARY RESOLUTION AMENDMENT

POSITION ADJUSTMENT ACTION TO BE COMPLETED BY HUMAN RESOURCES DEPARTMENT FOLLOWING BOARD ACTION

Adjust class(es) / position(s) as follows:



## REQUEST FOR PROJECT POSITIONS

Department \_\_\_\_\_

Date 10/26/2016

No. xxxxxx

1. Project Positions Requested:
  
2. Explain Specific Duties of Position(s)
  
3. Name / Purpose of Project and Funding Source (do not use acronyms i.e. SB40 Project or SDSS Funds)
  
4. Duration of the Project: Start Date \_\_\_\_\_ End Date \_\_\_\_\_  
Is funding for a specified period of time (i.e. 2 years) or on a year-to-year basis? Please explain.
  
5. Project Annual Cost
  - a. Salary & Benefits Costs: \_\_\_\_\_
  - b. Support Costs: \_\_\_\_\_  
(services, supplies, equipment, etc.)
  - c. Less revenue or expenditure: \_\_\_\_\_
  - d. Net cost to General or other fund: \_\_\_\_\_
  
6. Briefly explain the consequences of not filling the project position(s) in terms of:
  - a. potential future costs
  - b. legal implications
  - c. financial implications
  - d. political implications
  - e. organizational implications
  
7. Briefly describe the alternative approaches to delivering the services which you have considered. Indicate why these alternatives were not chosen.
  
8. Departments requesting new project positions must submit an updated cost benefit analysis of each project position at the halfway point of the project duration. This report is to be submitted to the Human Resources Department, which will forward the report to the Board of Supervisors. Indicate the date that your cost / benefit analysis will be submitted
  
9. How will the project position(s) be filled?
  - a. Competitive examination(s)
  - b. Existing employment list(s) Which one(s)? \_\_\_\_\_
  - c. Direct appointment of:
    1. Merit System employee who will be placed on leave from current job
    2. Non-County employee

Provide a justification if filling position(s) by C1 or C2

USE ADDITIONAL PAPER IF NECESSARY

## **P300 #21985 - ATTACHMENT No. 1**

### **ADD THE FOLLOWING 41 POSITIONS IN THE HEALTH SERVICES DEPARTMENT:**

- . One (1) 40/40 – Exempt Medical Staff Physician (VPW9)  
Salary level 1P5-2312 (\$11,052 - \$14,864)
- . One (1) 40/40 – Family Nurse Practitioner (VWSB)  
Salary level L35-1873 (\$9,249 - \$11,242)
- . One (1) 40/40 – Public Health Nurse (VVXA)  
Salary level LT2-1832 (\$7,663 - \$10,306)
- . One (1) 40/40 – Registered Nurse - Experienced Level (VWXD)  
Salary level L3H-0400 (\$8,049 - \$8,972)
- . One (1) 40/40 – Licensed Vocational Nurse (VT7G)  
Salary level TAX-1287 (\$4,129 - \$5,273)
- . One (1) 40/40 – Substance Abuse Counselor (VHVC)  
Salary level TC5-1436 (\$4,797 - \$5,831)
- . One (1) 40/40 – Clerk – Senior Level (JWXC)  
Salary level 3RX-1033 (\$3,210 – \$4,100)
- . One (1) 40/40 – Mental Health Clinical Specialist (VQSB)  
Salary level TC2-1384 (\$4,694 - \$6,969)
- . One (1) 40/40 – Community Health Worker II (VKVB)  
Salary level TC5-1043 (\$3,251 - \$3,951)
- . One (1) 40/40 – Community Health Worker Specialist (VKTA)  
Salary level TC5-1103 (\$3,450 - \$4,193)
- . One (1) 40/40 – Medical Social Worker I (X4WB)  
Salary level 255-1369 (\$4,317 - \$5,247)
- . One (1) 40/40 – Health Services Planner/Evaluator – Level B (VCXD)  
Salary level ZB2-1323 (\$4,419 - \$7,242)
- . Two (2) 40/40 – Health Services Administrator – Level C (VANH)  
Salary level ZB2-1723 (\$6,567 - \$8,407)
- . One (1) 40/40 – Mental Health Program Manager (VQDC)  
Salary level ZA5-1844 (\$7,186 - \$8,734)

- . Three (3) 40/40 – Mental Health Program Supervisor (VQHP)  
Salary level ZA5-1749 (\$6,541 - \$7,950)
- . One (1) 40/40 – Director Public Health Clinic Services (VVGGS)  
Salary level ZA5-2177 (\$9,992 - \$12,146)
- . Four (4) 40/40 – Public Health Nurse Program Manager (VWHL)  
Salary level ZA5-1989 (\$8,902 - \$10,821)
- . Four (4) 40/40 – Public Health Program Specialist I (VBSD)  
Salary level ZA5-1602 (\$5,655 - \$6,873)
- . One (1) 40/40 – Public Health Program Specialist II (VBND)  
Salary level ZA5-1711 (\$6,299 - \$7,657)
- . One (1) 40/40 – Substance Abuse Program Manager (VHGE)  
Salary level ZA5-1750 (\$6,547 - \$7,958)
- . Three (3) 40/40 – Substance Abuse Program Supervisor (VHHB)  
Salary level ZA5-1682 (\$6,121 - \$7,440)
- . Two (2) 40/40 – Health Services Information Systems Programmer/Analyst (LBTC)  
Salary level ZB5-1787 (\$6,791 - \$9,101)
- . One (1) 40/40 – Health Services Information Technology Security Specialist (LBSD)  
Salary level ZB5-1884 (\$7,476 - \$10,019)
- . One (1) 40/40 – Health Services Information Technology Project Manager (LBGF)  
Salary level ZA5-1884 (\$7,476 - \$10,019)
- . Four (4) 40/40 – Health Services Systems Analyst II (LBVC)  
Salary level ZB5-1784 (\$6,771 - \$9,074)
- . One (1) 40/40 – Database Administrator (LWSA)  
Salary level ZB5-1834 (\$7,115 - \$9,535)

C.16

### POSITION ADJUSTMENT REQUEST

NO. 21985  
DATE 10/19/2016

Department Health Services

Department No./  
Budget Unit No. 0450 Org No. 6377 Agency No. A18

Action Requested: Add 41 permanent full-time positions in varied classifications in the Health Services Department, as specified in Attachment No. 1.

Proposed Effective Date: 11/2/2016

Classification Questionnaire attached: Yes  No  / Cost is within Department's budget: Yes  No

Total One-Time Costs (non-salary) associated with request: \$0.00

Estimated total cost adjustment (salary / benefits / one time):

Total annual cost	<u>\$6,605,676.01</u>	Net County Cost	<u>\$0.00</u>
Total this FY	<u>\$3,302,828.00</u>	N.C.C. this FY	<u>\$0.00</u>

SOURCE OF FUNDING TO OFFSET ADJUSTMENT 100% offset with Whole Person Care Pilot Program

Department must initiate necessary adjustment and submit to CAO.  
Use additional sheet for further explanations or comments.

Jo-Anne Linares

\_\_\_\_\_  
(for) Department Head

REVIEWED BY CAO AND RELEASED TO HUMAN RESOURCES DEPARTMENT

Enid Mendoza

10/26/2016

\_\_\_\_\_  
Deputy County Administrator

\_\_\_\_\_  
Date

HUMAN RESOURCES DEPARTMENT RECOMMENDATIONS

DATE 10/26/2016

See Attachment No. 1

Amend Resolution 71/17 establishing positions and resolutions allocating classes to the Basic / Exempt salary schedule.

Effective:  Day following Board Action.  
 \_\_\_\_\_(Date)

Gladys Scott Reid

10/26/2016

\_\_\_\_\_  
(for) Director of Human Resources

\_\_\_\_\_  
Date

COUNTY ADMINISTRATOR RECOMMENDATION:

DATE 10/26/2016

Approve Recommendation of Director of Human Resources  
 Disapprove Recommendation of Director of Human Resources  
 Other: \_\_\_\_\_

Enid Mendoza

\_\_\_\_\_  
(for) County Administrator

BOARD OF SUPERVISORS ACTION:

Adjustment is APPROVED  DISAPPROVED

David J. Twa, Clerk of the Board of Supervisors  
and County Administrator

DATE 11-1-16

BY Crisis Heac

APPROVAL OF THIS ADJUSTMENT CONSTITUTES A PERSONNEL / SALARY RESOLUTION AMENDMENT

POSITION ADJUSTMENT ACTION TO BE COMPLETED BY HUMAN RESOURCES DEPARTMENT FOLLOWING BOARD ACTION

Adjust class(es) / position(s) as follows:



Contra  
Costa  
County

To: Board of Supervisors  
From: Melinda Cervantes, County Librarian  
Date: November 1, 2016

Subject: El Cerrito Library Donation of approximately \$80,000 from the James S. DeLoach Trust

---

**RECOMMENDATION(S):**

APPROVE and AUTHORIZE the County Librarian to accept a restricted donation in an estimated amount of \$80,000 from the James S. DeLoach Trust, for the exclusive use in support of the El Cerrito Library.

**FISCAL IMPACT:**

The donation will provide \$80,000 for library services that may include library open hours, purchase of library materials, and programming for the El Cerrito Library.

**BACKGROUND:**

James S. DeLoach generously bequeathed 4% of his trust to the El Cerrito Library. He was a resident of Kensington and frequented several of the nearby public libraries and thus decided to support the El Cerrito Library through this gift from his estate. The approximate value of his donation is \$80,000. The bequest will support library services that may include library open hours, purchase of library materials, and programming.

**CONSEQUENCE OF NEGATIVE ACTION:**

The James S. DeLoach Trust bequest will not be received for the El Cerrito Library.

**CHILDREN'S IMPACT STATEMENT:**

Communities that are Safe and Provide a High Quality of Life for Children and Families: The James S. DeLoach Trust bequest will support library services for children and families by providing access, materials and programs that enrich lives.

---

<input checked="" type="checkbox"/> APPROVE	<input type="checkbox"/> OTHER
<input checked="" type="checkbox"/> RECOMMENDATION OF CNTY ADMINISTRATOR	<input type="checkbox"/> RECOMMENDATION OF BOARD COMMITTEE

---

Action of Board On: **11/01/2016**  APPROVED AS RECOMMENDED  OTHER

Clerks Notes:

**VOTE OF SUPERVISORS**

AYE: John Gioia, District I Supervisor  
Candace Andersen, District II Supervisor  
Mary N. Piepho, District III Supervisor  
Karen Mitchoff, District IV Supervisor  
Federal D. Glover, District V Supervisor

I hereby certify that this is a true and correct copy of an action taken and entered on the minutes of the Board of Supervisors on the date shown.

ATTESTED: November 1, 2016

David J. Twa, County Administrator and Clerk of the Board of Supervisors

By: Chris Heck, Deputy

Contact: Alison McKee  
925-927-3290

cc:



Contra  
Costa  
County

To: Board of Supervisors  
From: Melinda Cervantes, County Librarian  
Date: November 1, 2016

Subject: El Cerrito Library Donation of approximately \$100,000 from the Eugene S. Troy Trust

---

**RECOMMENDATION(S):**

APPROVE and AUTHORIZE the County Librarian to accept a restricted donation in an estimated amount of \$100,000 from the Eugene S. Troy Trust, for the exclusive use in support of the El Cerrito Library.

**FISCAL IMPACT:**

The donation will provide \$100,000 for library services that may include library open hours, purchase of library materials, and programming for the El Cerrito Library.

**BACKGROUND:**

Eugene S. Troy generously bequeathed 2% of his trust to the El Cerrito Library. He was a resident of Kensington and frequented several of the nearby public libraries and thus decided to support the El Cerrito Library through this gift from his estate. The approximate value of his donation is \$100,000. The bequest will support library services that may include library open hours, purchase of library materials, and programming.

**CONSEQUENCE OF NEGATIVE ACTION:**

The Eugene S. Troy Trust bequest will not be received for the El Cerrito Library.

**CHILDREN'S IMPACT STATEMENT:**

Communities that are Safe and Provide a High Quality of Life for Children and Families: The Eugene S. Troy Trust bequest will support library services for children and families by providing access, materials and programs that enrich lives.

APPROVE

OTHER

RECOMMENDATION OF CNTY  
ADMINISTRATOR

RECOMMENDATION OF BOARD  
COMMITTEE

Action of Board On: 11/01/2016

APPROVED AS  
RECOMMENDED

OTHER

Clerks Notes:

**VOTE OF SUPERVISORS**

AYE: John Gioia, District I Supervisor  
Candace Andersen, District II  
Supervisor  
Mary N. Piepho, District III  
Supervisor  
Karen Mitchoff, District IV  
Supervisor  
Federal D. Glover, District V  
Supervisor

I hereby certify that this is a true and correct copy of an action taken and entered on the minutes of the Board of Supervisors on the date shown.

ATTESTED: November 1, 2016

David J. Twa, County Administrator and Clerk of the Board of Supervisors

By: Chris Heck, Deputy

Contact: Alison McKee  
925-927-3290

cc:



Contra  
Costa  
County

To: Board of Supervisors  
From: Kathy Gallagher, Employment & Human Services Director  
Date: November 1, 2016

Subject: California Department of Aging Funding, Amendment 1

---

**RECOMMENDATION(S):**

ACCEPT Resolution No. 2016/600 to approve and authorize the Employment and Human Services Director, or designee, to execute a contract amendment with California Department of Aging, effective September 30, 2016, to increase the payment limit by \$344,004 to a new payment limit of \$4,302,156 for Older Americans Act services to low income older County residents with no change in the term July 1, 2016 through June 30 2017.

**FISCAL IMPACT:**

County to receive an amount up to \$4,302,156 (includes Agreement AP-1617-07 Amendment 1 amount of \$344,004) from California Department of Aging. (100% Federal) (No additional County match)

**BACKGROUND:**

The Employment and Human Services Department, Area Agency on Aging, provides services to low income older County residents as defined by Title III and VII of the Older Americans Act. Services include supportive services, ombudsman services, congregate nutrition services, home delivered meals, disease prevention, family caregiver services, and elder abuse prevention services. Additional funding will support enhanced service delivery.

**CONSEQUENCE OF NEGATIVE ACTION:**

Without additional funding, current service levels would not be enhanced.

---

<input checked="" type="checkbox"/> APPROVE	<input type="checkbox"/> OTHER
<input checked="" type="checkbox"/> RECOMMENDATION OF CNTY ADMINISTRATOR	<input type="checkbox"/> RECOMMENDATION OF BOARD COMMITTEE

---

Action of Board On: **11/01/2016**  APPROVED AS RECOMMENDED  OTHER

Clerks Notes:

**VOTE OF SUPERVISORS**

- AYE: John Gioia, District I Supervisor  
Candace Andersen, District II Supervisor  
Mary N. Piepho, District III Supervisor  
Karen Mitchoff, District IV Supervisor  
Federal D. Glover, District V Supervisor

I hereby certify that this is a true and correct copy of an action taken and entered on the minutes of the Board of Supervisors on the date shown.

ATTESTED: November 1, 2016

David J. Twa, County Administrator and Clerk of the Board of Supervisors

By: Chris Heck, Deputy

Contact: Elaine Burren,  
925-313-1717

cc:

CHILDREN'S IMPACT STATEMENT:

Not applicable.

AGENDA ATTACHMENTS

Resolution No. 2016/600

MINUTES ATTACHMENTS

Res 2016/600 signed



**THE BOARD OF SUPERVISORS OF CONTRA COSTA COUNTY, CALIFORNIA**  
**and for Special Districts, Agencies and Authorities Governed by the Board**

Adopted this Resolution on 11/01/2016 by the following vote:

		<b>John Gioia</b>
		<b>Candace Andersen</b>
<b>AYE:</b>	<input type="text" value="5"/>	<b>Mary N. Piepho</b>
		<b>Karen Mitchoff</b>
		<b>Federal D. Glover</b>
<b>NO:</b>	<input type="text"/>	
<b>ABSENT:</b>	<input type="text"/>	
<b>ABSTAIN:</b>	<input type="text"/>	
<b>RECUSE:</b>	<input type="text"/>	



**Resolution No. 2016/600**

In the Matter Of: California Department of Aging Funding, Agreement No. AP-1617-07, Amendment 1

WHEREAS, the Employment and Human Services Department, Area Agency on Aging, provides services to and receives funding for services to low income older County residents, and,

WHEREAS, services include supportive services, ombudsman services, congregate nutrition services, home delivered meals, disease prevention, family caregiver services, and elder abuse prevention, and,

WHEREAS, the California Department of Aging has made additional funding available to County for these services.

Now, Therefore, Be It Resolved: that the Contra Costa County Board of Supervisors approve and authorize the Employment and Human Services Director, or designee, to execute a contract amendment with the California Department of Aging to increase the payment limit by \$344,004 to a new payment limit of \$4,302,156 for Older Americans Act services to low income older County residents with no change in the term July 1, 2016 through June 30, 2017.

I hereby certify that this is a true and correct copy of an action taken and entered on the minutes of the Board of Supervisors on the date shown.

**ATTESTED: November 1, 2016**

David J. Twa, County Administrator and Clerk of the Board of Supervisors

**Contact: Elaine Burres, 925-313-1717**

By: Chris Heck, Deputy

**cc:**

**THE BOARD OF SUPERVISORS OF CONTRA COSTA COUNTY, CALIFORNIA**  
**and for Special Districts, Agencies and Authorities Governed by the Board**

Adopted this Resolution on 11/01/2016 by the following vote:

**John Gioia**  
**Candace Andersen**  
**Mary N. Piepho**  
**Karen Mitchoff**  
**Federal D. Glover**

AYE:  5

NO:

ABSENT:

ABSTAIN:

RECUSE:



**Resolution No. 2016/600**

In the Matter Of: California Department of Aging Funding, Agreement No. AP-1617-07, Amendment 1

WHEREAS, the Employment and Human Services Department, Area Agency on Aging, provides services to and receives funding for services to low income older County residents, and,

WHEREAS, services include supportive services, ombudsman services, congregate nutrition services, home delivered meals, disease prevention, family caregiver services, and elder abuse prevention, and,

WHEREAS, the California Department of Aging has made additional funding available to County for these services.

Now, Therefore, Be It Resolved: that the Contra Costa County Board of Supervisors approve and authorize the Employment and Human Services Director, or designee, to execute a contract amendment with the California Department of Aging to increase the payment limit by \$344,004 to a new payment limit of \$4,302,156 for Older Americans Act services to low income older County residents with no change in the term July 1, 2016 through June 30, 2017.

I hereby certify that this is a true and correct copy of an action taken and entered on the minutes of the Board of Supervisors on the date shown.

**ATTESTED: November 1, 2016**

David J. Twa, County Administrator and Clerk of the Board of Supervisors

Contact: Elaine Burres, 925-313-1717

*Chris Heck*  
By: Chris Heck, Deputy

cc:





Contra  
Costa  
County

To: Board of Supervisors  
From: William Walker, M.D., Health Services Director  
Date: November 1, 2016

Subject: Grant Award #29-338-21 from the Department of Health Care Services, Children Medical Services

---

**RECOMMENDATION(S):**

Approve and authorize the Health Services Director, or his designee, to accept, on behalf of the County, Grant Award #29-338-21, from the Department of Health Care Services, Children Medical Services, to pay the County an amount not to exceed \$1,929,816 for the Child Health and Disability Prevention (CHDP) and the Health Care Program for Children in Foster Care (HCPCFC), for the period from July 1, 2016 through June 30, 2017.

**FISCAL IMPACT:**

Approval of this grant award will result in \$1,929,816 of funding from the California Department of Health Care Services State and the Federal Financial Participation for the County’s Child Health and Disability Prevention (CHDP) and the Health Care Program for Children in Foster Care (HCPCFC) projects. A county match of \$411,459 in County General Funds is required.

**BACKGROUND:**

The CHDP Program carries out State mandates regarding early and periodic

---

<input checked="" type="checkbox"/> APPROVE	<input type="checkbox"/> OTHER
<input checked="" type="checkbox"/> RECOMMENDATION OF CNTY ADMINISTRATOR	<input type="checkbox"/> RECOMMENDATION OF BOARD COMMITTEE

---

Action of Board On: **11/01/2016**  APPROVED AS RECOMMENDED  OTHER

Clerks Notes:

**VOTE OF SUPERVISORS**

- AYE: John Gioia, District I Supervisor  
Candace Andersen, District II Supervisor  
Mary N. Piepho, District III Supervisor  
Karen Mitchoff, District IV Supervisor  
Federal D. Glover, District V Supervisor

I hereby certify that this is a true and correct copy of an action taken and entered on the minutes of the Board of Supervisors on the date shown.

ATTESTED: November 1, 2016  
David J. Twa, County Administrator and Clerk of the Board of Supervisors

By: Chris Heck, Deputy

Contact: Dan Peddycord,  
925-313-6712

BACKGROUND: (CONT'D)

screening, diagnosis, treatment and case coordination of health and dental services for children on Medi-Cal or within the 200% poverty level. These services are federally required and consistent with approved standards of medical practice. The CHDP program is responsible for provider certifications, network and resource development, training, outreach, care coordination, follow up and communications with medical and dental providers.

This program works closely with community providers, other health related agencies, Managed Care, County Departments including Employment and Human Services, Probation, and Community Services as well as other Health Services Divisions to provide a wide variety of health related consultation services.

The goal of the Program is to provide access to Contra Costa County low income children ages 0-21 for periodic wellness care, provide further diagnosis and treatment for medical and dental problems, assist with enrollment into a comprehensive plan, provide case coordination, follow up, and liaison services to various resources. The HCPCFC program carries out federal and state mandates for children in foster care and the juvenile justice system.

Approval of Grant Award #29-338-21 is necessary for the continuation of this long standing state and federal funding that supports these ongoing Public Health Programs: Child Health and Disability Prevention (CHDP) and the Health Care Program for Children in Foster Care (HCPCFC) through June 30, 2017.

CONSEQUENCE OF NEGATIVE ACTION:

If this contract is not approved, the County will not receive funding to support the CHDP and the HCPCFC programs to comply with State and Federal requirements.

CHILDREN'S IMPACT STATEMENT:

Not applicable.



Contra  
Costa  
County

To: Board of Supervisors  
From: William Walker, M.D., Health Services Director  
Date: November 1, 2016

Subject: Amendment Agreement #28-660-14 with the City of Antioch for Community Development Department, Block Grant (CDBG) funding

**RECOMMENDATION(S):**

Approve and Authorize the Health Services Director, or his designee, to execute, on behalf of the County, Amendment Agreement #28-660-14 with the City of Antioch for its Community Development Department, Block Grant (CDBG) funding, effective July 1, 2016, to pay the County an amount not to exceed \$10,000, for continuation of the operation of the Adult Interim Housing Program, for the period from July 1, 2016 through June 30, 2017.

**FISCAL IMPACT:**

Approval of this amendment agreement will result in an amount not to exceed \$10,000 of emergency housing and supportive services to individuals year-round. (No County funds required)

**BACKGROUND:**

The Health Services Department applied for funding from the City of Antioch to operate the emergency shelter program at full capacity on a year-round basis. Each year, the shelters provide interim housing and support services to over 800 individuals. The Community Development Block Grant program, funded by the U.S. Department of Housing and Urban Development, is a source of public funding providing valuable housing and service benefits to homeless persons of Contra Costa County. Without such funding, the emergency shelter program may have to

<input checked="" type="checkbox"/> APPROVE	<input type="checkbox"/> OTHER
<input checked="" type="checkbox"/> RECOMMENDATION OF CNTY ADMINISTRATOR	<input type="checkbox"/> RECOMMENDATION OF BOARD COMMITTEE

Action of Board On: **11/01/2016**  APPROVED AS RECOMMENDED  OTHER

Clerks Notes:

**VOTE OF SUPERVISORS**

AYE: John Gioia, District I Supervisor  
Candace Andersen, District II Supervisor  
Mary N. Piepho, District III Supervisor  
Karen Mitchoff, District IV Supervisor  
Federal D. Glover, District V Supervisor

I hereby certify that this is a true and correct copy of an action taken and entered on the minutes of the Board of Supervisors on the date shown.

ATTESTED: November 1, 2016  
David J. Twa, County Administrator and Clerk of the Board of Supervisors

Contact: CYNTHIA BELON  
925-957-5201

By: Chris Heck, Deputy

BACKGROUND: (CONT'D)

operate at a reduced capacity.

On November 3, 2015, the Board of Supervisors approved submission of Application and Agreement #28-660-13 for continuous services and operation of the County's Adult Interim Housing Program and to perform all responsibilities in relation to receipt of the funding for the period from July 1, 2015 through June 30, 2016, including agreeing to indemnify and hold harmless the City from any claims arising out of the performance of this Agreement.

Approval of Amendment Agreement #28-660-14 will allow the County to continue to receive CDBG funding from the City of Antioch, for continuous services and operation of the County's Adult Interim Housing Program through June 30, 2017.

CONSEQUENCE OF NEGATIVE ACTION:

If this Amendment is not approved, County will not receive funding and without such funding, the emergency shelter program may have to operate at a reduced capacity.

CHILDREN'S IMPACT STATEMENT:

Not applicable.



Contra  
Costa  
County

To: Board of Supervisors  
From: William Walker, M.D., Health Services Director  
Date: November 1, 2016

Subject: Amendment Agreement #28-528-52 with the County of Alameda Health Care Services Agency

---

**RECOMMENDATION(S):**

Approve and authorize the Health Services Director, or his designee, to execute, on behalf of the County, Amendment Agreement #28-528-52 with the County of Alameda Health Care Services Agency, effective March 1, 2016, to increase the total payment to County by \$160,108 from \$1,397,786, to a new amount not to exceed \$1,557,894, for additional coordination of essential services to Contra Costa County residents with HIV Disease and their families, with no change in the original term of March 1, 2016 through February 28, 2017.

**FISCAL IMPACT:**

Approval of this amendment agreement will result in an increase of \$160,108 from the County of Alameda, as the Grantee of federal funds under the Ryan White HIV/AIDS Treatment Modernization Act of 2006, Part A. No County match is required.

**BACKGROUND:**

The U.S. Department of Health and Human Services has designated the County

---

<input checked="" type="checkbox"/> APPROVE	<input type="checkbox"/> OTHER
<input checked="" type="checkbox"/> RECOMMENDATION OF CNTY ADMINISTRATOR	<input type="checkbox"/> RECOMMENDATION OF BOARD COMMITTEE

---

Action of Board On: **11/01/2016**  APPROVED AS RECOMMENDED  OTHER

Clerks Notes:

**VOTE OF SUPERVISORS**

- AYE: John Gioia, District I Supervisor  
Candace Andersen, District II Supervisor  
Mary N. Piepho, District III Supervisor  
Karen Mitchoff, District IV Supervisor  
Federal D. Glover, District V Supervisor

I hereby certify that this is a true and correct copy of an action taken and entered on the minutes of the Board of Supervisors on the date shown.

ATTESTED: November 1, 2016  
David J. Twa, County Administrator and Clerk of the Board of Supervisors

By: Chris Heck, Deputy

Contact: Dan Peddycord,  
925-313-6712

BACKGROUND: (CONT'D)

of Alameda as “Grantee” for the purpose of administering the Ryan White HIV/AIDS Treatment Modernization Act of 2006, Part A, funds for coordination of essential services to Contra Costa County residents with HIV Disease and their families.

On June 7, 2016, the Board of Supervisors approved Contract #28-528-51 with the County of Alameda Health Care Services Agency, as the fiscal agent for Ryan White CARE Act, Title I and Minority AIDS Initiative funds, for coordination of services to Contra Costa residents with HIV disease and their families, for the period from March 1, 2016 through February 28, 2017.

Approval of Amendment Agreement #28-528-52 will provide additional funding to allow the County to continue providing coordination of services to Contra Costa residents with HIV disease and their families through February 28, 2017.

CONSEQUENCE OF NEGATIVE ACTION:

If this amendment agreement is not approved, County will not receive additional funds to provide continuous coordination of essential services to Contra Costa County residents with HIV Disease and their families.

CHILDREN'S IMPACT STATEMENT:

Not applicable.





Contra  
Costa  
County

To: Board of Supervisors  
From: John Kopchik, Director, Conservation & Development Department  
Date: November 1, 2016

Subject: First Amendment to the Franchise Agreement with Crockett Garbage Company

---

**RECOMMENDATION(S):**

APPROVE and AUTHORIZE the Chair of the Board of Supervisors to execute the First Amendment to the County Franchise Agreement with Crockett Garbage Company to extend the term of the Agreement through December 31, 2016 in order to allow time for finalizing the terms and conditions of a proposed nine-year extension of the Crockett Franchise and associated proposed service enhancements and rate adjustment.

**FISCAL IMPACT:**

There is no impact to the County General Fund. Approval of the recommended Franchise Amendment would obligate Crockett Sanitary Service to continue paying solid waste/recycling franchise fees to the County through the end of this calendar year.

**BACKGROUND:**

On November 5, 1996, the County entered into a franchise agreement with Walter Botta, the sole proprietor of the Crockett Garbage Company, to provide collection and recycling services for the unincorporated communities of Crockett, Port Costa and Tormey. Walter Botta immediately assigned his rights and obligations under the Agreement to Crockett Garbage Service, Inc. (name was subsequently changed to Crockett Sanitary Service, Inc.), which is a subsidiary of Richmond Sanitary Service, Inc. The term of the Agreement will end on November 5, 2016, unless amended to extend the term.

APPROVE

OTHER

RECOMMENDATION OF CNTY  
ADMINISTRATOR

RECOMMENDATION OF BOARD  
COMMITTEE

---

Action of Board On: **11/01/2016**  APPROVED AS  
RECOMMENDED

OTHER

Clerks Notes:

**VOTE OF SUPERVISORS**

AYE: John Gioia, District I Supervisor  
Candace Andersen, District II  
Supervisor  
Mary N. Piepho, District III Supervisor  
Karen Mitchoff, District IV Supervisor  
Federal D. Glover, District V Supervisor

I hereby certify that this is a true and correct copy of an action taken and entered on the minutes of the Board of Supervisors on the date shown.

ATTESTED: November 1, 2016

David J. Twa, County Administrator and Clerk of the Board of Supervisors

Contact: Demian Hardman, (925)  
674-7826

By: Chris Heck, Deputy

cc:

BACKGROUND: (CONT'D)

County staff recommends that the agreement be extended through December 31, 2016, to allow both parties to finalize the terms of a proposed nine-year extension of the Crockett Franchise. This timing is preferable so that the proposed nine-year extension and the associated service enhancements could take effect on January 1, 2017, which coincides with the planned implementation of the Base Year Rate adjustment that is expected to be considered by the Board in November/December 2016. Crockett Sanitary Service, Inc., has executed the First Amendment recommended for approval by the Board.

This is the last of the four Franchise Agreements that the County entered into between 1993 and 1996. It is also the last proposed to be amended in order to extend the term for nine years (ten years for the other franchises). In order to seek direction from the Board regarding whether or not to extend these solid waste and recycling collection franchise agreements again in future years, staff will return to the Board of Supervisors three years prior to their termination dates, which fall between 2023 and 2025. This three-year "tickler" should allow adequate time for staff to conduct a Request for Proposals process should the Board so direct, including soliciting and selecting a contractor as well as completing negotiations with the selected contractor.

CONSEQUENCE OF NEGATIVE ACTION:

Unless and until an Amendment or new Franchise Agreement was approved by both parties, as of November 5, 2016, the County would no longer have a Franchise Agreement in effect to regulate the waste and recycling collection services provided to residential and commercial customers currently being served by Crockett Sanitary Service in Crockett, Port Costa or Tormey.



Contra  
Costa  
County

To: Board of Supervisors  
From: William Walker, M.D., Health Services Director  
Date: November 1, 2016

Subject: Agreement #28-706-19 with Public Health Foundation Enterprises, Inc.

---

**RECOMMENDATION(S):**

Approve and authorize the Health Services Director, or his designee, to execute, on behalf of the County, Agreement #28-706-19 with Public Health Foundation Enterprises, Inc., a nonprofit organization, in an amount up to \$92,874 in funding, to support the Centers for Disease Control and Prevention’s Emerging Infections Program - Retail Foods Project for the period from September 1, 2016 through August 31, 2017.

**FISCAL IMPACT:**

The Agreement will result in up to \$92,874 in funding by Centers for Disease Control and Prevention Cooperative Grant for the Emerging Infections Program through the Public Health Foundation Enterprises, Inc. (No County match required)

**BACKGROUND:**

The National Antimicrobial Resistance Monitoring System (NARMS) for Enteric Bacteria was established in 1996 to monitor bacterial resistance, specifically, the resistance

---

APPROVE  OTHER  
 RECOMMENDATION OF CNTY ADMINISTRATOR  RECOMMENDATION OF BOARD COMMITTEE

---

Action of Board On: **11/01/2016**  APPROVED AS RECOMMENDED  OTHER

Clerks Notes:

**VOTE OF SUPERVISORS**

AYE: John Gioia, District I Supervisor  
Candace Andersen, District II Supervisor  
Mary N. Piepho, District III Supervisor  
Karen Mitchoff, District IV Supervisor  
Federal D. Glover, District V Supervisor

I hereby certify that this is a true and correct copy of an action taken and entered on the minutes of the Board of Supervisors on the date shown.

ATTESTED: November 1, 2016  
David J. Twa, County Administrator and Clerk of the Board of Supervisors

Contact: Daniel Peddycord  
925-313-6712

By: Chris Heck, Deputy

BACKGROUND: (CONT'D)

among Salmonella and other enteric bacteria. The 17 participating state health departments forward every tenth human Salmonella isolate to CDC for antimicrobial susceptibility testing.

The CDC is requesting that additional Emerging Infections Program (EIP) sites participate in the study of foodborne bacteria. Such bacteria is not uncommon and often is associated with the use of antimicrobial agents in food animals, especially in retail food. This study will assist in generating a database that may be utilized to augment the development of intervention programs to stem the high prevalence of antimicrobial resistance in the meal and poultry food supply. The goal of the study is to determine the prevalence of antimicrobial resistance among Salmonella, Campylobacter, E.coli and enterococci isolated from a sample of chicken, ground turkey, ground beef and pork chops purchased from selected grocery stores in the catchment area of the California EIP FoodNet site. This will include samples collected from Contra Costa, Alameda and San Francisco County retail grocery stores.

Approval of this Agreement #28-706-19 will allow continuous funding to support the Emerging Infections Program - Retail Foods Project, through August 31, 2017. This Agreement includes mutual indemnification.

CONSEQUENCE OF NEGATIVE ACTION:

If this amendment is not approved, the County will not receive additional funding to continue provide services for the Emerging Infections Program - Retail Foods Project.

CHILDREN'S IMPACT STATEMENT:

Not applicable.



Contra  
Costa  
County

To: Board of Supervisors  
From: John Kopchik, Director, Conservation & Development Department  
Date: November 1, 2016

Subject: Tassajara Parks Environmental Impact Report Contract Amendment

---

**RECOMMENDATION(S):**

APPROVE and AUTHORIZE the Conservation and Development Director, or designee, to execute a contract amendment with First Carbon Solutions, to increase the payment limit by \$71,385 to a new payment limit of \$404,424 with no change to the term of September 10, 2014 through September 9, 2018, for services required to prepare the Recirculated Draft Environmental Impact Report (RDEIR) for the Tassajara Parks Project in the Tassajara Valley (San Ramon area).

**FISCAL IMPACT:**

No impact. The applicant is responsible for paying the costs of the additional work to evaluate the impacts of the project.

**BACKGROUND:**

The Department of Conservation and Development contracted with First Carbon Solutions in September of 2014 to prepare an Environmental Impact Report ( EIR) for the Tassajara Parks Project. The project involves construction of a 125 unit residential subdivision and includes substantial dedication of park land in the Tassajara Valley / San Ramon area. The project requires approval of General Plan Amendment, Rezoning, Subdivision, and Development Plan applications.

The County released a RDEIR on September 29, 2016 for a 45 day public comment period. During the public comment period on the initial Draft EIR substantial new information arose regarding the Water Supply Evaluation dated December 2015, upon which the Draft EIR relied for analysis of impacts to utilities and service systems.

APPROVE

OTHER

RECOMMENDATION OF CNTY  
ADMINISTRATOR

RECOMMENDATION OF BOARD  
COMMITTEE

---

Action of Board On: **11/01/2016**  APPROVED AS  
RECOMMENDED

OTHER

Clerks Notes:

**VOTE OF SUPERVISORS**

AYE: John Gioia, District I Supervisor  
Candace Andersen, District II  
Supervisor  
Mary N. Piepho, District III  
Supervisor  
Karen Mitchoff, District IV  
Supervisor  
Federal D. Glover, District V  
Supervisor

I hereby certify that this is a true and correct copy of an action taken and entered on the minutes of the Board of Supervisors on the date shown.

ATTESTED: November 1, 2016

David J. Twa, County Administrator and Clerk of the Board of Supervisors

By: Chris Heck, Deputy

Contact: John Osborne,  
925-674-7793

cc:

BACKGROUND: (CONT'D)

A lead agency is required to recirculate an EIR when significant new information regarding the project is added to the EIR after public notice of availability of the Draft EIR and before certification. Additionally, the RDEIR has been updated to include a more detailed project description and clarification, as appropriate, related to anesthetics, agricultural resources, air quality, biology, geology and transportation.

First Carbon Solutions has identified additional tasks necessary to complete the RDEIR, that include project management, incorporation of the Memorandum of Understanding in the project topic areas and the response to comments. This is the fourth budget amendment. The increased payment limit is necessary to cover the additional work. There is no change to the term of the contract which is valid until September 9, 2018.

CONSEQUENCE OF NEGATIVE ACTION:

If the Board does not authorize the EIR contract amendment, there would not be sufficient funds for First Carbon Solutions to complete the EIR.

ATTACHMENTS



Contra  
Costa  
County

To: Board of Supervisors  
From: William Walker, M.D., Health Services Director  
Date: November 1, 2016

Subject: Amendment #26-577-13 with All Health Services Corporation

---

**RECOMMENDATION(S):**

Approve and authorize the Health Services Director, or designee, to execute, on behalf of the County, Contract Amendment Agreement #26-577-13 with All Health Services Corporation, a corporation, effective July 1, 2016, to amend Contract #26-577-12, to increase the payment limit by \$2,389,412, from \$1,967,000 to a new payment limit of \$4,356,412 with no change in the original term of October 1, 2015 through September 30, 2017.

**FISCAL IMPACT:**

This amendment is funded 100% Hospital Enterprise Fund I. (No rate increase)

**BACKGROUND:**

On October 20, 2015, the Board of Supervisors approved Contract #26-577-12 with All Health Services Corporation, for the provision of temporary medical staffing services at the Contra Costa Regional Medical Center and Health Centers (CCRMC) and Detention facilities, including registered nurses, certified nursing assistants, ophthalmology technicians, physical and occupational therapists, and psychiatric technicians, for the period from October 1, 2015 through September 30, 2017. At the time of negotiations, the payment limit was based on target levels of utilization. However, the utilization during the term of the agreement was higher than originally anticipated. Approval of Contract Amendment Agreement #26-577-13 will allow the Contractor to provide additional hours of temporary medical staffing services through September 30, 2017.

---

APPROVE

OTHER

RECOMMENDATION OF CNTY ADMINISTRATOR

RECOMMENDATION OF BOARD  
COMMITTEE

---

Action of Board On: **11/01/2016**  APPROVED AS RECOMMENDED  OTHER

Clerks Notes:

**VOTE OF SUPERVISORS**

I hereby certify that this is a true and correct copy of an action taken and entered on the minutes of the Board of Supervisors on the date shown.

ATTESTED: November 1, 2016

Contact: Anna Roth,  
925-370-5102

David J. Twa, County Administrator and Clerk of the Board of Supervisors

By: , Deputy

cc: K Cyr, M Wilhelm

CONSEQUENCE OF NEGATIVE ACTION:

If this amendment is not approved, patients requiring medical services will not have access to Contractor's services.

CHILDREN'S IMPACT STATEMENT:

Not applicable.

CLERK'S ADDENDUM

*Speaker: Richard Andazola, Teamsters 856. RELISTED to November 15, 2016.*





Contra  
Costa  
County

To: Board of Supervisors  
From: John Kopchik, Director, Conservation & Development Department  
Date: November 1, 2016

Subject: Contract with NBS Government Finance Group to Evaluate and Update the Land Development Fee Schedule

**RECOMMENDATION(S):**

1. APPROVE and AUTHORIZE the Conservation and Development Director, or designee, to execute, on behalf of the County, a contract with NBS Government Finance Group, including modified indemnification language, in an amount not to exceed \$67,561 to evaluate and recommend updates to the Land Development Fee Schedule used by the Department of Conservation and Development (DCD) and the Public Works Department (PWD) to recover costs of land use development services provided by the two Departments for the period November 1, 2016 to October 31, 2017.
2. REFER the subject of updating the Land Development Fee Schedule to the Internal Operations Committee of the Board of Supervisors.

**FISCAL IMPACT:**

The cost of this contract will be paid from the operating budgets of the Department of Conservation and Development and the Public Works Department using Land Development Fees.

APPROVE
   
  OTHER  
 RECOMMENDATION OF CNTY
   
  RECOMMENDATION OF BOARD  
 ADMINISTRATOR
   
 COMMITTEE

Action of Board On: **11/01/2016**
 APPROVED AS
   
 OTHER  
 RECOMMENDED

Clerks Notes:

**VOTE OF SUPERVISORS**

AYE: John Gioia, District I Supervisor  
 Candace Andersen, District II Supervisor  
 Mary N. Piepho, District III Supervisor  
 Karen Mitchoff, District IV Supervisor  
 Federal D. Glover, District V Supervisor

I hereby certify that this is a true and correct copy of an action taken and entered on the minutes of the Board of Supervisors on the date shown.

ATTESTED: November 1, 2016

David J. Twa, County Administrator and Clerk of the Board of Supervisors

By: Chris Heck, Deputy

Contact: Jason Crapo,  
925-674-7723

cc:

## BACKGROUND:

The Department of Conservation and Development (DCD) and Public Works Department (PWD) are the two County departments with primary responsibility for regulating and permitting land development activities within the County's jurisdiction. The two Departments are responsible for the County's planning, building inspection and public infrastructure functions. The Departments review permit applications and issue permits for a wide variety of land use activities, including land use permits, building permits, and encroachment permits, to name just a few.

DCD and PWD collect fees from permit applicants to offset the costs the two Departments incur providing services to administer their permitting processes. Fees collected by the two Departments are based on the County's Land Development Fee Schedule (Fee Schedule).

The current Fee Schedule is based largely on a fee study performed by an outside consultant in the mid 1990's, and has not been comprehensively updated since that time. As a result, many of the fees and fee deposit amounts in the Fee Schedule - as well as the apportionment of fees shared between DCD and PWD - are based on an analysis that is over 20 years old and may no longer correspond to current operating conditions (although it should be noted that hourly rates for staff time and project valuation tables have been updated over the years to reflect current costs). To address these circumstances, DCD and PWD seek services from NBS to comprehensively update the Fee Schedule based on current operating conditions.

The County has a long-standing practice that Land Development services provided by DCD and PWD are fully self-supporting and that all costs incurred by the two Departments providing such services are fully paid for through fees collected by the Departments. No County general funds are allocated to subsidize these services.

Therefore, the goal of the Fee Schedule is to collect fees that fairly and equitably recover the costs incurred by DCD and PWD in providing land development services. Since the current fee schedule has not been comprehensively reviewed and updated in over 20 years, DCD and PWD anticipate that adjustments to many existing fees and inclusion of some new fees will likely be required to meet this goal.

The County's standard indemnification clause has been modified in this contract such that if the County elects to defend itself from legal claim covered by the Contractor's general liability insurance policy, the Contractor is not obligated to reimburse the County for the costs of such defense to the extent such costs are not accepted by the Contractor's insurance provider.

DCD and PWD recommend that this topic be referred to the Internal Operations Committee for status updates before returning to the Board for further action.

## CONSEQUENCE OF NEGATIVE ACTION:

If the Board does not approve the proposed contract, DCD and PWD will not be able to utilize the services of NBS to evaluate the Land Development Fee Schedule.



**Contra  
Costa  
County**

To: Board of Supervisors  
From: John Kopchik, Director, Conservation & Development Department  
Date: November 1, 2016

Subject: Contract with Ten2Eleven Business Solutions to Modernize the Joint Billing System

---

**RECOMMENDATION(S):**

APPROVE and AUTHORIZE the Conservation and Development Director, or designee, to execute a contract with Ten2Eleven Business Solutions in an amount not to exceed \$137,280 for information technology consulting services for the period November 1, 2016 to October 31, 2017.

**FISCAL IMPACT:**

The cost of this contract will be paid from the operating budgets of the Department of Conservation and Development and the Public Works Department, using Land Development Fees.

**BACKGROUND:**

The Joint Billing System ("JBS") is a critical information technology ("IT") system supporting the County's land development activities. JBS is used by staff in the Department of Conservation and Development ("DCD") and Public Works Department ("PWD") for tracking staff time and billing permit applicants for services provided. JBS interfaces with other County IT systems, such as the County's finance system and DCD's permitting system, Accela Automation. JBS was developed internally by County IT staff beginning in the late 1990's, and went live in 2002. While JBS has fulfilled its intended purpose, as the system ages some limitations have become apparent, and it is now prudent to review its functionality. Current technology offers opportunities for a billing system that improves the customer services experience for the public and enhances operational efficiencies for DCD and PWD.

---

<input checked="" type="checkbox"/> APPROVE	<input type="checkbox"/> OTHER
<input checked="" type="checkbox"/> RECOMMENDATION OF CNTY ADMINISTRATOR	<input type="checkbox"/> RECOMMENDATION OF BOARD COMMITTEE

---

Action of Board On: **11/01/2016**  APPROVED AS RECOMMENDED  OTHER

Clerks Notes:

**VOTE OF SUPERVISORS**

AYE: John Gioia, District I Supervisor  
Candace Andersen, District II Supervisor  
Mary N. Piepho, District III Supervisor  
Karen Mitchoff, District IV Supervisor  
Federal D. Glover, District V Supervisor

I hereby certify that this is a true and correct copy of an action taken and entered on the minutes of the Board of Supervisors on the date shown.

ATTESTED: November 1, 2016

David J. Twa, County Administrator and Clerk of the Board of Supervisors

By: Chris Heck, Deputy

Contact: Jason Crapo,  
925-674-7722

cc:

BACKGROUND: (CONT'D)

DCD and PWD are seeking to modernize JBS so that it continues to serve its current functions, but also adds additional functionality to meet current business needs. The new solution will need to perform the functions that JBS currently performs, including billing and interface with other relevant County IT systems. In addition the two user Departments are seeking a solution that adds additional functionality, such as on-line customer billing and payments, use of credit cards as a means to receive payment and conduct on-line transactions, a more intuitive user interface, the ability to produce management reports, greater flexibility to adapt to future changes in business needs, and greater ease of maintenance for County IT staff. Any new system must also migrate data from the current system to allow for a smooth transition, with no interruption to business operations.

The purpose of this contract is so that DCD and PWD can obtain analysis and advice from Ten2Eleven Business Solutions ("Ten2Eleven") regarding options and recommendations for modernizing JBS to meet the business needs of the two Departments. Possible alternatives may include commercial off-the-shelf solutions, custom components, or modifications to the existing system.

Ten2Eleven will work with DCD and PWD staff to gain understanding of the operation work flows and business processes of the two Departments, as well as an understanding of the role JBS plays in these business processes and how JBS interrelates with other County IT systems. Ten2Eleven will produce a report for DCD and PWD that describes and evaluates the current JBS system, identifies alternatives for an IT solution to meet the County's needs, discuss tradeoffs associated with various alternatives, and recommends a solution to best meet the needs of the two Departments.

CONSEQUENCE OF NEGATIVE ACTION:

If the Board does not approve the proposed contract, DCD and PWD will not be able to access consulting services to assist in modernizing the current Joint Billing System.



Contra  
Costa  
County

To: Board of Supervisors  
From: Julia R. Bueren, Public Works Director/Chief Engineer  
Date: November 1, 2016

Subject: Contract with PDM Group, Inc., for Right of Way Services, City of Napa Roundabouts Project

---

**RECOMMENDATION(S):**

APPROVE and AUTHORIZE the Public Works Director, or designee, to execute a contract with PDM Group, Inc., including modified indemnification language, in an amount not to exceed \$25,000, to provide County right of way services related to the City of Napa First and Second Street Roundabouts Project, for the period from October 1, 2016, through Septemeber 30, 2017.

**FISCAL IMPACT:**

100% City of Napa Funds.

**BACKGROUND:**

On April 19, 2016, the Board of Supervisors approved the Real Property Services Agreement with the City of Napa (City) to provide right of way services to acquire certain interests in real property for their First and Second Street Roundabouts Project.

The Public Works Real Estate Division is currently understaffed and in need of additional right of way acquisition assistance for the City's project. The City's project schedule is under a constricted timeline and assistance is necessary to meet the acquisition deadlines for the City's federally funded project. Under this contract, PDM Group, Inc. will provide right of way services to the County related to the City's project.

The contract includes modified indemnification language. The requirement that the contractor defend the County and pays for any County-selected defense of any claims has been deleted.

APPROVE

OTHER

RECOMMENDATION OF CNTY  
ADMINISTRATOR

RECOMMENDATION OF BOARD  
COMMITTEE

---

Action of Board On: **11/01/2016**  APPROVED AS  
RECOMMENDED

OTHER

Clerks Notes:

**VOTE OF SUPERVISORS**

AYE: John Gioia, District I Supervisor  
Candace Andersen, District II  
Supervisor  
Mary N. Piepho, District III  
Supervisor  
Karen Mitchoff, District IV  
Supervisor  
Federal D. Glover, District V  
Supervisor

I hereby certify that this is a true and correct copy of an action taken and entered on the minutes of the Board of Supervisors on the date shown.

ATTESTED: November 1, 2016

David J. Twa, County Administrator and Clerk of the Board of Supervisors

By: Chris Heck, Deputy

Contact: Karen Laws, (925)  
313-2228

cc:

CONSEQUENCE OF NEGATIVE ACTION:

The County will not be able to provide adequate services to the City.



Contra  
Costa  
County

To: Board of Supervisors  
From: William Walker, M.D., Health Services Director  
Date: November 1, 2016

Subject: Contract #24-681-84(14) with United Family Care, LLC (dba Family Courtyard)

---

**RECOMMENDATION(S):**

Approve and authorize the Health Services Director, or his designee, to execute, on behalf of the County, Contract #24-681-84(14) with United Family Care, LLC (dba Family Courtyard), a limited liability company, in an amount not to exceed \$453,840, to provide Augmented Board and Care Services, for the period from December 1, 2016 through November 30, 2017.

**FISCAL IMPACT:**

This contract is funded 100% Mental Health Realignment funds. (No rate increase)

**BACKGROUND:**

This contract meets the social needs of the County's population in that it provides augmentation of room and board, and twenty-four hour emergency residential care and supervision to eligible mentally disordered clients, who are specifically referred by the mental health program staff and who are served by County mental health services.

On October 20, 2015, the Board of Supervisors approved Contract #24-681-84(13) with United Family Care, LLC (dba Family Courtyard), for the period December 1, 2015

---

<input checked="" type="checkbox"/> APPROVE	<input type="checkbox"/> OTHER
<input checked="" type="checkbox"/> RECOMMENDATION OF CNTY ADMINISTRATOR	<input type="checkbox"/> RECOMMENDATION OF BOARD COMMITTEE

---

Action of Board On: **11/01/2016**  APPROVED AS RECOMMENDED  OTHER

Clerks Notes:

**VOTE OF SUPERVISORS**

- AYE: John Gioia, District I Supervisor  
Candace Andersen, District II Supervisor  
Mary N. Piepho, District III Supervisor  
Karen Mitchoff, District IV Supervisor  
Federal D. Glover, District V Supervisor

I hereby certify that this is a true and correct copy of an action taken and entered on the minutes of the Board of Supervisors on the date shown.

ATTESTED: November 1, 2016  
David J. Twa, County Administrator and Clerk of the Board of Supervisors

Contact: CYNTHIA BELON,  
925-957-5201

By: Chris Heck, Deputy

BACKGROUND: (CONT'D)

through November 30, 2016, for the provision of augmented board and care services for County-referred mentally disordered clients.

Approval of Contract #24-681-84(14) will allow the contractor to continue to provide augmented board and care services, through November 30, 2017.

CONSEQUENCE OF NEGATIVE ACTION:

If this contract is not approved, County residents will not receive services provided by this contractor.

CHILDREN'S IMPACT STATEMENT:

Not applicable.





Contra  
Costa  
County

To: Board of Supervisors  
From: William Walker, M.D., Health Services Director  
Date: November 1, 2016

Subject: Novation Contract #24-680-31 with Telecare Corporation

---

**RECOMMENDATION(S):**

Approve and authorize the Health Services Director, or his designee, to execute, on behalf of the County, Novation Contract #24-680-31 with Telecare Corporation, a corporation, in an amount not to exceed \$1,352,909, to provide gero-psychiatric and subacute mental health care services to severely and persistently mentally ill clients for the period from July 1, 2016 through June 30, 2017.

**FISCAL IMPACT:**

This contract is funded 76% Mental Health Realignment and 24% Hospital Utilization Review (No rate increase)

**BACKGROUND:**

This Contract meets the social needs of County's population by providing gero-psychiatric services and subacute care for severely and persistently mentally ill (SPMI) County residents at Contractor's Villa Fairmont Mental Health Center, Garfield Neuro-Behavioral Center, Gladman Psychiatric Health Facility, and Morton Bakar Center. This Contract is part of the Department's cost saving plan to reduce the number of high cost State Hospital beds by developing alternative placements.

On December 15, 2015, the Board of

---

<input checked="" type="checkbox"/> APPROVE	<input type="checkbox"/> OTHER
<input checked="" type="checkbox"/> RECOMMENDATION OF CNTY ADMINISTRATOR	<input type="checkbox"/> RECOMMENDATION OF BOARD COMMITTEE

---

Action of Board On: **11/01/2016**  APPROVED AS RECOMMENDED  OTHER

Clerks Notes:

**VOTE OF SUPERVISORS**

- AYE: John Gioia, District I Supervisor  
Candace Andersen, District II Supervisor  
Mary N. Piepho, District III Supervisor  
Karen Mitchoff, District IV Supervisor  
Federal D. Glover, District V Supervisor

I hereby certify that this is a true and correct copy of an action taken and entered on the minutes of the Board of Supervisors on the date shown.

ATTESTED: November 1, 2016

David J. Twa, County Administrator and Clerk of the Board of Supervisors

By: Chris Heck, Deputy

Contact: Cynthia Belon,  
925-957-5201

BACKGROUND: (CONT'D)

Supervisors approved Novation Contract #24-680-28 (as amended by Contract Amendment Agreement #24-680-29) with Telecare Corporation, for the period from July 1, 2015 through June 30, 2016, which included a six-month automatic extension through December 31, 2016, for the provision of gero-psychiatric and subacute mental health care for Severely and Persistently Mentally Ill clients.

Approval of Novation Contract #24-680-31 replaces the automatic extension under the prior Contract and allows the Contractor to continue providing services through June 30, 2017.

CONSEQUENCE OF NEGATIVE ACTION:

If this contract is not approved, County's SPMI adults will not have access to Contractor's gero-psychiatric and subacute care services resulting in placements in State Hospital facilities at greater cost to the County.

CHILDREN'S IMPACT STATEMENT:

Not Applicable



Contra  
Costa  
County

To: Board of Supervisors  
From: Julia R. Bueren, Public Works Director/Chief Engineer  
Date: November 1, 2016

Subject: Approve a Purchase Order Amendment with Lehr Auto Electric, Inc.

---

**RECOMMENDATION(S):**

APPROVE and AUTHORIZE the Purchasing Agent, or designee, to execute, on behalf of the Public Works Director, a purchase order amendment with Lehr Auto Electric, Inc., to increase the payment limit by \$400,000, to a new payment limit of \$650,000, and extend the termination date from January 31, 2017 to January 31, 2018 for emergency vehicle parts, accessories and fabrication, Countywide.

**FISCAL IMPACT:**

100% Fleet Internal Service Fund

**BACKGROUND:**

Public Works Fleet Services purchases and outfits all emergency services vehicles for the County. This includes vehicles from the Sheriff, Public Works, Animal Services, Probation, District Attorney and Health Services. The Sheriff's vehicles take up the vast majority of this commodity. Outfitting includes lights, consoles, electrical switching, wiring, and other hard parts such as partitions, consoles and trunk slider trays. This commodity was originally bid on BidSync #1301-003 and awarded to Lehr Auto Electric, Inc.

APPROVE

OTHER

RECOMMENDATION OF CNTY  
ADMINISTRATOR

RECOMMENDATION OF BOARD  
COMMITTEE

---

Action of Board On: **11/01/2016**

APPROVED AS  
RECOMMENDED

OTHER

Clerks Notes:

**VOTE OF SUPERVISORS**

AYE: John Gioia, District I Supervisor  
Candace Andersen, District II Supervisor  
Mary N. Piepho, District III Supervisor  
Karen Mitchoff, District IV Supervisor  
Federal D. Glover, District V Supervisor

I hereby certify that this is a true and correct copy of an action taken and entered on the minutes of the Board of Supervisors on the date shown.

ATTESTED: November 1, 2016

David J. Twa, County Administrator and Clerk of the Board of Supervisors

By: Chris Heck, Deputy

Contact: Stan Burton, (925)  
313-7077

cc:

CONSEQUENCE OF NEGATIVE ACTION:

If this purchase order amendment is not approved, the purchase of emergency vehicle parts and accessories through Lehr Auto Electric, Inc. will discontinue.



Contra  
Costa  
County

To: Board of Supervisors  
From: William Walker, M.D., Health Services Director  
Date: November 1, 2016

Subject: Agreement #23-581-1 with San Ramon Valley Fire Protection District

---

**RECOMMENDATION(S):**

Approve and authorize the Health Services Director, or his designee, to execute, on behalf of the County, Agreement #23-581-1 with San Ramon Valley Fire Protection District, a government agency, in an amount not to exceed \$375,000, to coordinate the services of a Fire Services Emergency Medical Services (EMS) Medical Director, for the period from December 15, 2016 through December 14, 2019.

**FISCAL IMPACT:**

This Contract is funded 100% by Measure H Funding.

**BACKGROUND:**

The purpose of this Agreement is to provide enhancements in fire service based education, training, patient safety and quality improvement for fire services providers within the Contra Costa EMS Systems. On August 20, 2015, the San Ramon Valley Fire Department's Board of Directors authorized to recruit and hire a Fire Services EMS Medical Director on behalf of the following protection agencies: East Contra Costa Fire Protection District, El Cerrito Fire Department,

---

APPROVE

OTHER

RECOMMENDATION OF CNTY  
ADMINISTRATOR

RECOMMENDATION OF BOARD  
COMMITTEE

---

Action of Board On: **11/01/2016**  APPROVED AS  
RECOMMENDED

OTHER

Clerks Notes:

**VOTE OF SUPERVISORS**

AYE: John Gioia, District I Supervisor  
Candace Andersen, District II Supervisor  
Mary N. Piepho, District III Supervisor  
Karen Mitchoff, District IV Supervisor  
Federal D. Glover, District V Supervisor

I hereby certify that this is a true and correct copy of an action taken and entered on the minutes of the Board of Supervisors on the date shown.

ATTESTED: November 1, 2016

David J. Twa, County Administrator and Clerk of the Board of Supervisors

By: Chris Heck, Deputy

Contact: Patricia Frost,  
925-646-4690

BACKGROUND: (CONT'D)

Moraga Orinda Fire District, Pinole Fire Department, Richmond Fire Department, Rodeo-Hercules Fire Protection District and San Ramon Valley Fire Protection District.

Under Agreement #23-581-1, the San Ramon Valley Fire Protection District will coordinate the services of a Fire Services EMS Medical Director, through December 14, 2019.

CONSEQUENCE OF NEGATIVE ACTION:

If this agreement is not approved, Contra Costa County's EMS Systems will not receive enhancements supporting education, training, patients safety and quality improvements for its providers.

CHILDREN'S IMPACT STATEMENT:

Not applicable.



Contra  
Costa  
County

To: Board of Supervisors  
From: William Walker, M.D., Health Services Director  
Date: November 1, 2016

Subject: Agreement #23-580-1 with San Ramon Valley Fire Protection District

---

**RECOMMENDATION(S):**

Approve and authorize the Health Services Director, or his designee, to execute, on behalf of the County, Agreement #23-580-1 with San Ramon Valley Fire Protection District, a government agency, in an amount not to exceed \$295,200, to provide electronic patient care records hosting and support services for the Contra Costa EMS System, for the period from December 15, 2016 through December 14, 2019.

**FISCAL IMPACT:**

This Contract is funded 100% by Measure H Funding.

**BACKGROUND:**

The purpose of this Agreement is for the County to pay San Ramon Valley Fire Protection District (District) for costs associated with services provided by Definitive Networks, Inc., who will provide electronic patient care records hosting and support services for certain County fire protection agencies.

Approval of Agreement #23-580-1 will allow the San Ramon Valley Fire Protection District to continue

---

APPROVE

OTHER

RECOMMENDATION OF CNTY  
ADMINISTRATOR

RECOMMENDATION OF BOARD  
COMMITTEE

---

Action of Board On: **11/01/2016**  APPROVED AS  
RECOMMENDED

OTHER

Clerks Notes:

**VOTE OF SUPERVISORS**

AYE: John Gioia, District I Supervisor  
Candace Andersen, District II  
Supervisor  
Mary N. Piepho, District III  
Supervisor  
Karen Mitchoff, District IV  
Supervisor  
Federal D. Glover, District V  
Supervisor

I hereby certify that this is a true and correct copy of an action taken and entered on the minutes of the Board of Supervisors on the date shown.

ATTESTED: November 1, 2016

David J. Twa, County Administrator and Clerk of the Board of Supervisors

By: Chris Heck, Deputy

Contact: Patricia Frost,  
925-646-4690

BACKGROUND: (CONT'D)

to provide electronic patient care records hosting and support services, through December 14, 2019. This contract includes mutual indemnification.

CONSEQUENCE OF NEGATIVE ACTION:

If this agreement is not approved, Contra Costa County's EMS Systems will not receive enhancements supporting education, training, patients safety and quality improvements for its providers.

CHILDREN'S IMPACT STATEMENT:

Not applicable.





Contra  
Costa  
County

To: Board of Supervisors  
From: William Walker, M.D., Health Services Director  
Date: November 1, 2016

Subject: Contract #26-681-6 with Mark Kogan, M.D.

**RECOMMENDATION(S):**

Approve and authorize the Health Services Director, or his designee, to execute, on behalf of the County, Contract #26-681-6 with Mark Kogan, M.D., an individual, in an amount not to exceed \$450,000, to provide gastroenterology services at Contra Costa Regional Medical Center and Health Centers (CCRMC) for the period from January 1, 2017 through December 31, 2019.

**FISCAL IMPACT:**

This Contract is funded 100% Hospital Enterprise Fund I. (No rate increase)

**BACKGROUND:**

On December 3, 2013, the Board of Supervisors approved Contract #26-681-5 with Mark Kogan, M.D., for the provision of gastroenterology services including, but not limited to: clinic coverage, gastrointestinal laboratory sessions, consultation, training, on-call coverage, and medical and/or surgical procedures, at CCRMC, for the period from January 1, 2014 through December 31, 2016. Approval of Contract #26-681-6 will allow Contractor to continue providing gastroenterology services through December 31, 2019.

**CONSEQUENCE OF NEGATIVE ACTION:**

If this contract is not approved, patients requiring gastroenterology services at CCRMC will not have access to Contractor's services.

APPROVE

OTHER

RECOMMENDATION OF CNTY  
ADMINISTRATOR

RECOMMENDATION OF BOARD  
COMMITTEE

Action of Board On: **11/01/2016**  APPROVED AS  
RECOMMENDED

OTHER

Clerks Notes:

**VOTE OF SUPERVISORS**

AYE: John Gioia, District I Supervisor  
Candace Andersen, District II  
Supervisor  
Mary N. Piepho, District III Supervisor  
Karen Mitchoff, District IV Supervisor  
Federal D. Glover, District V Supervisor

I hereby certify that this is a true and correct copy of an action taken and entered on the minutes of the Board of Supervisors on the date shown.

ATTESTED: November 1, 2016

David J. Twa, County Administrator and Clerk of the Board of Supervisors

Contact: Samir Shah, M.D.,  
925-370-5525

By: Chris Heck, Deputy

cc: K Cyr, M Wilhelm

CHILDREN'S IMPACT STATEMENT:

Not applicable.



Contra  
Costa  
County

To: Board of Supervisors  
From: William Walker, M.D., Health Services Director  
Date: November 1, 2016

Subject: Contract #26-786-5 with Peter A. Castillo, M.D., Inc.

---

**RECOMMENDATION(S):**

Approve and authorize the Health Services Director, or his designee, to execute, on behalf of the County, Contract #26-786-5 with Peter A. Castillo, M.D., Inc., a corporation, in an amount not to exceed \$382,000, to provide urogynecology services at Contra Costa Regional Medical Center and Health Centers (CCRMC) for the period from December 1, 2016 through November 30, 2017.

**FISCAL IMPACT:**

This Contract is funded 100% Hospital Enterprise Fund I. (No rate increase)

**BACKGROUND:**

On November 17, 2015, the Board of Supervisors approved Contract #26-786-3 (as amended by Contract Amendment Agreement #26-786-4) with Peter A. Castillo, M.D., Inc. for the provision of urogynecology services including administrative duties and medical and/or surgical procedures at CCRMC for the period from December 1, 2015 through November 30, 2016. Approval of Contract #26-786-5 will allow Contractor to continue providing urogynecology services at CCRMC through November 30, 2017.

**CONSEQUENCE OF NEGATIVE ACTION:**

If this contract is not approved, patients requiring urogynecology services will not have access to Contractor's services.

---

<input checked="" type="checkbox"/> APPROVE	<input type="checkbox"/> OTHER
<input checked="" type="checkbox"/> RECOMMENDATION OF CNTY ADMINISTRATOR	<input type="checkbox"/> RECOMMENDATION OF BOARD COMMITTEE

---

Action of Board On: **11/01/2016**  APPROVED AS RECOMMENDED  OTHER

Clerks Notes:

**VOTE OF SUPERVISORS**

AYE: John Gioia, District I Supervisor  
Candace Andersen, District II Supervisor  
Mary N. Piepho, District III Supervisor  
Karen Mitchoff, District IV Supervisor  
Federal D. Glover, District V Supervisor

I hereby certify that this is a true and correct copy of an action taken and entered on the minutes of the Board of Supervisors on the date shown.

ATTESTED: November 1, 2016  
David J. Twa, County Administrator and Clerk of the Board of Supervisors

Contact: Samir Shah, M.D.,  
925-370-5525

By: Chris Heck, Deputy

CHILDREN'S IMPACT STATEMENT:

Not applicable.



Contra  
Costa  
County

To: Board of Supervisors  
From: Dianne Dinsmore, Human Resources Director  
Date: November 1, 2016

Subject: Contract Amendment/Extension with Benefit Coordinators Corporation

---

**RECOMMENDATION(S):**

APPROVE and AUTHORIZE the Director of Human Resources, or designee, to execute a contract amendment with Benefit Coordinators Corporation, including indemnification language, to extend the term from September 2, 2016 through August 31, 2017 and increase the payment limit by \$75,000 to a new payment limit of \$150,000 to assist the County in complying with the reporting and eligibility requirements of the Affordable Care Act.

**FISCAL IMPACT:**

The cost of this contract is 100% funded through the Benefits Administration Fee.

**BACKGROUND:**

Starting in 2016 and in each consecutive year, the Affordable Care Act (ACA) requires that the County file information returns with the Internal Revenue Service and to provide statements to employees about the health insurance coverage offered by Contra Costa County. Benefit Coordinators Corporation will assist the Human Resources Department to comply with the ACA requirements.

**CONSEQUENCE OF NEGATIVE ACTION:**

If the contract is not approved and the County does not file timely and accurate information, we may be liable for significant fines imposed by the federal government.

---

<input checked="" type="checkbox"/> APPROVE	<input type="checkbox"/> OTHER
<input checked="" type="checkbox"/> RECOMMENDATION OF CNTY ADMINISTRATOR	<input type="checkbox"/> RECOMMENDATION OF BOARD COMMITTEE

---

Action of Board On: **11/01/2016**  APPROVED AS RECOMMENDED  OTHER

Clerks Notes:

**VOTE OF SUPERVISORS**

AYE: John Gioia, District I Supervisor  
Candace Andersen, District II Supervisor  
Mary N. Piepho, District III Supervisor  
Karen Mitchoff, District IV Supervisor  
Federal D. Glover, District V Supervisor

I hereby certify that this is a true and correct copy of an action taken and entered on the minutes of the Board of Supervisors on the date shown.

ATTESTED: November 1, 2016  
David J. Twa, County Administrator and Clerk of the Board of Supervisors

By: Chris Heck, Deputy

Contact: Ann Elliott, 925-335-1747

cc: Nancy Zandonella, Lisa Lopez, Ann Elliott



**Contra  
Costa  
County**

To: Board of Supervisors  
From: William Walker, M.D., Health Services Director  
Date: November 1, 2016

Subject: Purchase Order with the Sourcing Group Company

---

**RECOMMENDATION(S):**

Approve and authorize the Purchasing Agent, on behalf of the Health Services Department, to execute a Purchase Order with the Sourcing Group Company, in an amount not to exceed \$800,000 for the purchase of medical forms, envelopes and business cards for the Contra Costa Regional Medical Center (CCRMC) and the Contra Costa Health Centers (CCHC) for the period November 1, 2016 through October 31, 2018.

**FISCAL IMPACT:**

100% funding is included in the Hospital Enterprise Fund I budget.

**BACKGROUND:**

The Sourcing Group Company provides Contra Costa Health Services with all forms, envelopes and business cards. Contra Costa County has utilized The Sourcing Group (previously known as Tully-Wihr) since 1998 for management and storage of stock forms, printing of specialty forms, delivery and on-line tracking and ordering of all forms.

**CONSEQUENCE OF NEGATIVE ACTION:**

If this purchase order is not approved, we will not be able to provide the staff at CCRMC and CCHC with the forms needed for patient care.

**CHILDREN'S IMPACT STATEMENT:**

Not applicable.

---

<input checked="" type="checkbox"/> APPROVE	<input type="checkbox"/> OTHER
<input checked="" type="checkbox"/> RECOMMENDATION OF CNTY ADMINISTRATOR	<input type="checkbox"/> RECOMMENDATION OF BOARD COMMITTEE

---

Action of Board On: **11/01/2016**  APPROVED AS RECOMMENDED  OTHER

Clerks Notes:

**VOTE OF SUPERVISORS**

- AYE: John Gioia, District I Supervisor  
 Candace Andersen, District II Supervisor  
 Mary N. Piepho, District III Supervisor  
 Karen Mitchoff, District IV Supervisor  
 Federal D. Glover, District V Supervisor

I hereby certify that this is a true and correct copy of an action taken and entered on the minutes of the Board of Supervisors on the date shown.

ATTESTED: November 1, 2016

David J. Twa, County Administrator and Clerk of the Board of Supervisors

By: Chris Heck, Deputy

Contact: Anna Roth, 925-370-5101

cc: Tasha Scott, Marcy Wilhelm, Crystal Grayson



Contra  
Costa  
County

To: Board of Supervisors  
From: William Walker, M.D., Health Services Director  
Date: November 1, 2016

Subject: Purchase Order Amendment with Freedom Hygiene, Inc.

---

**RECOMMENDATION(S):**

Approve and authorize the Purchasing Agent, on behalf of the Health Services Department, to execute an amendment to Purchase Order with Freedom Hygiene, Inc. to add \$38,000 for a new total of \$128,000 to provide and service disposal bins for the restrooms at the Contra Costa Regional Medical Center (CCRMC) and Contra Costa Health Centers with no change in the original term of January 12, 2015 through July 11, 2017.

**FISCAL IMPACT:**

100% funding is included in the Hospital Enterprises Fund I Budget.

**BACKGROUND:**

Centers for Disease Control and Prevention has recommended Freedom Hygiene, Inc. to provide and service the sanitary bins in the restrooms to improve sanitation and reduce the risks of infection to staff and patients. The increased payment limit is needed to account for additional services at the West County Health Center, since it has been added to the list of locations Freedom Hygiene is servicing.

**CONSEQUENCE OF NEGATIVE ACTION:**

If this Purchase Order is not approved, a greater risk of infection will exist.

APPROVE

OTHER

RECOMMENDATION OF CNTY  
ADMINISTRATOR

RECOMMENDATION OF BOARD  
COMMITTEE

---

Action of Board On: **11/01/2016**  APPROVED AS  
RECOMMENDED

OTHER

Clerks Notes:

**VOTE OF SUPERVISORS**

AYE: John Gioia, District I Supervisor  
Candace Andersen, District II  
Supervisor  
Mary N. Piepho, District III  
Supervisor  
Karen Mitchoff, District IV  
Supervisor  
Federal D. Glover, District V  
Supervisor

I hereby certify that this is a true and correct copy of an action taken and entered on the minutes of the Board of Supervisors on the date shown.

ATTESTED: November 1, 2016

David J. Twa, County Administrator and Clerk of the Board of Supervisors

By: Chris Heck, Deputy

Contact: Anna Roth, 925-370-5101

cc: Tasha Scott, Marcy Wilhelm, Margaret Harris

CHILDREN'S IMPACT STATEMENT:

Not applicable.





Contra  
Costa  
County

To: Board of Supervisors  
From: Todd Billeci, County Probation Officer  
Date: November 1, 2016

Subject: Purchase Order Amendment with Bay Cities Produce Co. Inc.

---

**RECOMMENDATION(S):**

APPROVE and AUTHORIZE the Purchasing Agent or designee to execute, on behalf of the Probation Department, a purchase order amendment with Bay Cities Produce Co., Inc. to increase the payment limit from \$95,000 to a new payment limit of \$245,000, for the purchase of whole and processed fresh fruits and vegetables at Juvenile Hall and Orin Allen Youth Rehabilitation Facility and to extend the term from December 31, 2016 to December 31, 2017.

**FISCAL IMPACT:**

The additional cost of \$150,000 is included in the Probation Department's annual budget and costs are partially offset by the National School Lunch Program.

**BACKGROUND:**

The Probation Department is required to provide residents detained at the Juvenile Hall and Orin Allen Youth Rehabilitation Facility with three meals and a snack each day. These meals must conform to the guidelines of Title 15 article 9 section 1461 CCR. In addition to the state mandated guidelines, breakfast and lunch must meet the requirements of the Hunger Free Kids Act of 2010 to qualify for reimbursement through the National School Lunch Program. Bay Cities Produce Co. is one of two respondents to solicitation 1409-079 that were subsequently awarded purchase orders.

APPROVE

OTHER

RECOMMENDATION OF CNTY  
ADMINISTRATOR

RECOMMENDATION OF BOARD  
COMMITTEE

Action of Board On: **11/01/2016**  APPROVED AS  
RECOMMENDED

OTHER

Clerks Notes:

**VOTE OF SUPERVISORS**

AYE: John Gioia, District I Supervisor  
Candace Andersen, District II  
Supervisor  
Mary N. Piepho, District III Supervisor  
Karen Mitchoff, District IV Supervisor  
Federal D. Glover, District V Supervisor

I hereby certify that this is a true and correct copy of an action taken and entered on the minutes of the Board of Supervisors on the date shown.

ATTESTED: November 1, 2016

David J. Twa, County Administrator and Clerk of the Board of Supervisors

Contact: Danielle Fokkema,  
925-313-4195

By: Chris Heck, Deputy

cc:

CONSEQUENCE OF NEGATIVE ACTION:

Department will be unable to supply fresh fruits and vegetables to the two juvenile facilities and will not be in compliance with California Code of Regulations Title 15 Minimum Standards for Juvenile Facilities.

CHILDREN'S IMPACT STATEMENT:

This action supports one of the community outcomes established in the Children's Report Card: 1) "Children and Youth Healthy and Preparing for Productive Adulthood".



Contra  
Costa  
County

To: Board of Supervisors  
From: William Walker, M.D., Health Services Director  
Date: November 1, 2016

Subject: Contract #74-413-6 with Young Men’s Christian Association of the East Bay

---

**RECOMMENDATION(S):**

Approve and authorize the Health Services Director, or his designee, to execute, on behalf of the County, Contract #74-413-6 with Young Men’s Christian Association of the East Bay, a non-profit corporation, in an amount not to exceed \$10,000, to provide development and implementation of internship programs for students participating in the Workforce Education and Training (WET) Program for the period from October 1, 2016 through September 30, 2017.

**FISCAL IMPACT:**

This Contract is funded 100% Mental Health Services Act. (No rate increase)

**BACKGROUND:**

On November 3, 2015, the Board of Supervisors approved Contract #74-413-5 with Young Men’s Christian Association of the East Bay, for the development and implementation of internship programs for students participating in the WET Program to obtain licenses in fields related to mental health and clinical practice, for the period from October 1, 2015 through September 30, 2016.

Approval of Contract

---

<input checked="" type="checkbox"/> APPROVE	<input type="checkbox"/> OTHER
<input checked="" type="checkbox"/> RECOMMENDATION OF CNTY ADMINISTRATOR	<input type="checkbox"/> RECOMMENDATION OF BOARD COMMITTEE

---

Action of Board On: **11/01/2016**  APPROVED AS RECOMMENDED  OTHER

Clerks Notes:

**VOTE OF SUPERVISORS**

A YE: John Gioia, District I Supervisor  
Candace Andersen, District II Supervisor  
Mary N. Piepho, District III Supervisor  
Karen Mitchoff, District IV Supervisor  
Federal D. Glover, District V Supervisor

I hereby certify that this is a true and correct copy of an action taken and entered on the minutes of the Board of Supervisors on the date shown.

ATTESTED: November 1, 2016

David J. Twa, County Administrator and Clerk of the Board of Supervisors

By: Chris Heck, Deputy

Contact: Cynthia Belon  
925-957-5201

BACKGROUND: (CONT'D)

#74-413-6 will allow Contractor to continue developing and implementing internship programs for students participating in the Workforce Education and Training (WET) Program through September 30, 2017. This contract includes changes to the County's Standard General Conditions, paragraph 18, Indemnification.

CONSEQUENCE OF NEGATIVE ACTION:

If this contract is not approved, interns will not receive education and training services provided by Young Men's Christian Association of the East Bay.

CHILDREN'S IMPACT STATEMENT:

Not applicable.



**Contra  
Costa  
County**

To: Board of Supervisors  
From: William Walker, M.D., Health Services Director  
Date: November 1, 2016

Subject: Contract #26-784-3 with Cardionet, LLC

---

**RECOMMENDATION(S):**

Approve and authorize the Health Services Director, or his designee, to execute, on behalf of the County, Contract #26-784-3 with Cardionet, LLC, a limited liability company, in an amount not to exceed \$135,000, to provide remote cardiac monitoring services for patients at Contra Costa Regional Medical Center (CCRMC), for the period from November 1, 2016 through October 31, 2017.

**FISCAL IMPACT:**

This contract is funded 100% by Hospital Enterprise Fund I. (No rate increase)

**BACKGROUND:**

In December 2015, the County Administrator approved and the Purchasing Services Manager executed Contract #26-784-1 (as amended by Amendment Agreement #26-784-2) with Cardionet, LLC, for the provision of cardiac monitoring services, for the period from November 1, 2015 through October 31, 2016.

Approval of Contract #26-784-3 will allow the Contractor to provide remote cardiac monitoring services through October 31, 2017.

---

APPROVE

OTHER

RECOMMENDATION OF CNTY  
ADMINISTRATOR

RECOMMENDATION OF BOARD  
COMMITTEE

---

Action of Board On: **11/01/2016**  APPROVED AS  
RECOMMENDED

OTHER

Clerks Notes:

**VOTE OF SUPERVISORS**

AYE: John Gioia, District I Supervisor  
Candace Andersen, District II  
Supervisor  
Mary N. Piepho, District III  
Supervisor  
Karen Mitchoff, District IV  
Supervisor  
Federal D. Glover, District V  
Supervisor

I hereby certify that this is a true and correct copy of an action taken and entered on the minutes of the Board of Supervisors on the date shown.

ATTESTED: November 1, 2016

David J. Twa, County Administrator and Clerk of the Board of Supervisors

By: Chris Heck, Deputy

Contact: Anna Roth, 925-370-5101

cc: Tasha Scott, M Wilhelm

CONSEQUENCE OF NEGATIVE ACTION:

If this contract is not approved, the CCRMC will not be able to provide remote cardiac monitoring services for its patients.

CHILDREN'S IMPACT STATEMENT:

Not applicable.



Contra  
Costa  
County

To: Board of Supervisors  
From: Kathy Gallagher, Employment & Human Services Director  
Date: November 1, 2016

Subject: Contract with UCSF Benioff Children's Hospital for Training Services

---

**RECOMMENDATION(S):**

APPROVE and AUTHORIZE the Employment & Human Services Department Director, or designee, to execute a contract, including a mutual indemnification language, with Children's Hospital & Research Center at Oakland, dba UCSF Benioff Children's Hospital Oakland, in an amount not to exceed \$15,000 to provide reflective supervision training for the period October 1, 2016 through June 30, 2017.

**FISCAL IMPACT:**

100% Federal funds  
CFDA #93.600  
Administration for Children and Families

**BACKGROUND:**

The Department's Community Services Bureau (CSB) operates childcare centers throughout the county to provide quality early care and education to program eligible families. The Head Start and Early Head Start programs, serving children ages 0 to 5 years, operates in an environment wherein the families face specific environmental challenges that require the supervisors of the childcare programs to have a set of abilities well suited to address the unique needs. The Bureau

---

APPROVE
  OTHER  
 RECOMMENDATION OF CNTY ADMINISTRATOR
  RECOMMENDATION OF BOARD COMMITTEE

---

Action of Board On: **11/01/2016**  APPROVED AS RECOMMENDED  OTHER

Clerks Notes:

**VOTE OF SUPERVISORS**

AYE: John Gioia, District I Supervisor  
 Candace Andersen, District II Supervisor  
 Mary N. Piepho, District III Supervisor  
 Karen Mitchoff, District IV Supervisor  
 Federal D. Glover, District V Supervisor

I hereby certify that this is a true and correct copy of an action taken and entered on the minutes of the Board of Supervisors on the date shown.

ATTESTED: November 1, 2016

David J. Twa, County Administrator and Clerk of the Board of Supervisors

By: Chris Heck, Deputy

Contact: CSB 925-681-6301

cc: Camilla Rand, Monique Young-Edwards, Cassandra Youngblood

BACKGROUND: (CONT'D)

has identified a specific type of professional development training, Reflective Supervision, that will assist the childcare program supervisors to better serve the population.

UCSF Benioff Children's Hospital has a training unit in the Early Intervention Program services, that are a good match for CSB. The department would like to establish a contract with UCSF Benioff to provide a 3-day training services to well equip the childcare program services in the practice of Reflective Supervision.

CONSEQUENCE OF NEGATIVE ACTION:

If not approved, training will not be provided to staff.

CHILDREN'S IMPACT STATEMENT:

None





**Contra  
Costa  
County**

To: Board of Supervisors  
From: William Walker, M.D., Health Services Director  
Date: November 1, 2016

Subject: Amendment Agreement #26-346-19 with the U.S. Department of Veterans Affairs

---

**RECOMMENDATION(S):**

Approve and authorize the Health Services Director, or his designee, to execute on behalf of the County, Amendment Agreement #26-346-19, with the U.S. Department of Veterans Affairs, Northern California Health Care System (VANCHCS), effective October 31, 2016, to amend Sharing Agreement #26-346-14 (as amended by Amendments #26-346-15 through #26-346-18), to increase the payment limit by \$800,000 from \$2,361,000 to a new total of \$3,161,000 and extend to termination date from October 31, 2016 to December 31, 2017.

**FISCAL IMPACT:**

This Amendment Agreement is funded in the Health Services Department's Hospital Enterprise Fund I Budget. The services provided for the County's patients under this Contract are billable to patients and third party payors.

**BACKGROUND:**

For many years, the County and U.S. Department of Veterans Affairs have maintained a mutual sharing agreement, which has made available to the County specialized medical

---

APPROVE  OTHER  
 RECOMMENDATION OF CNTY ADMINISTRATOR  RECOMMENDATION OF BOARD COMMITTEE

---

Action of Board On: **11/01/2016**  APPROVED AS RECOMMENDED  OTHER

Clerks Notes:

**VOTE OF SUPERVISORS**

AYE: John Gioia, District I Supervisor  
Candace Andersen, District II Supervisor  
Mary N. Piepho, District III Supervisor  
Karen Mitchoff, District IV Supervisor  
Federal D. Glover, District V Supervisor

I hereby certify that this is a true and correct copy of an action taken and entered on the minutes of the Board of Supervisors on the date shown.

ATTESTED: November 1, 2016

David J. Twa, County Administrator and Clerk of the Board of Supervisors

By: Chris Heck, Deputy

Contact: Anna Roth, 925-370-5101

cc: Tasha Scott, M Wihelm

BACKGROUND: (CONT'D)

services not otherwise available due to lack of resources, equipment, and personnel. These services included specialized laboratory testing, radiology services, nuclear medicine studies, CT scans, MRI's, dermatology, gastroenterology, urology, audiology and speech, and ophthalmology services. The County provided Emergency Room treatment and inpatient care, including certain ancillary services, for VA-referred patients.

On March 19, 2013, the Board of Supervisors approved Sharing Agreement #26-346-14 (as amended by Amendment Agreements #26-346-15 through #26-346-18) with VANCHCS (under the auspices of the VANCHCS Nuclear Regulatory Commission License) to provide a full range of Nuclear Medicine Services to County's patients at the VA Outpatient Clinic in Martinez and/or the Contra Costa Regional Medical Center's Nuclear Medicine Department, through October 31, 2016, including continuation of mutual indemnification to hold harmless both parties for any claims arising out of the performance of this agreement.

Approval of Amendment Agreement #26-346-19 will allow Contractor to continue providing nuclear medicine services to Contra Costa Regional Medical Center's Nuclear Medicine Department through December 31, 2017.

CONSEQUENCE OF NEGATIVE ACTION:

If this amendment is not approved, County's patients will not receive specialized nuclear medicine services.

CHILDREN'S IMPACT STATEMENT:

Not applicable.



Contra  
Costa  
County

To: Board of Supervisors  
From: Ed Woo, Chief Information Officer  
Date: November 1, 2016

Subject: Blanket Purchase Order with Graybar Electric Company for Supplies

---

**RECOMMENDATION(S):**

APPROVE and AUTHORIZE the Purchasing Agent or designee to execute, on behalf of the Chief Information Officer, a blanket purchase order with Graybar Electric Company in an amount not to exceed \$2,000,000 for the procurement of radio, telecommunications equipment and parts as needed, for the period January 1 through December 31, 2017.

**FISCAL IMPACT:**

\$2,000,000 (100% User Fees); all costs are charged to the ordering departments through DoIT's billing process.

**BACKGROUND:**

The Department of Information Technology's Telecommunications and Radio divisions need to be able to readily purchase parts and supplies, in order to complete Work Order requests and other jobs submitted by their customers. The pricing is pursuant to U.S. Communities Contract Master Agreement NO. MA-IS-1-040223 solicited by the County of Los Angeles, California, 3 year initial term, January 1, 2015 - December 31, 2017 with an option to renew for (2) additional (1) year periods.

In accordance with Administrative Bulletin No. 611.0, single item purchases in excess of \$100,000 require Board of Supervisors approval. The County Administrator's Office has reviewed this request and recommends approval.

---

APPROVE

OTHER

RECOMMENDATION OF CNTY ADMINISTRATOR

RECOMMENDATION OF BOARD  
COMMITTEE

---

Action of Board On: **11/01/2016**  APPROVED AS RECOMMENDED  OTHER

Clerks Notes:

**VOTE OF SUPERVISORS**

I hereby certify that this is a true and correct copy of an action taken and entered on the minutes of the Board of Supervisors on the date shown.

ATTESTED: November 1, 2016

Contact: Ed Woo (925)  
383-2688

David J. Twa, County Administrator and Clerk of the Board of Supervisors

By: , Deputy

cc:

CONSEQUENCE OF NEGATIVE ACTION:

If the action is not approved, DoIt will not have the necessary means to process and pay anticipated expenses through the Blanket Purchase Order.

CLERK'S ADDENDUM

***RELISTED to November 15, 2016.***



Contra  
Costa  
County

To: Board of Supervisors  
From: Beth Ward, Animal Services Director  
Date: November 1, 2016

Subject: Approve and Authorize a contract amendment with MWI Animal Health

---

**RECOMMENDATION(S):**

APPROVE and AUTHORIZE the Purchasing Agent to execute, on behalf of the Animal Services Director, or designee, a purchase order amendment with MWI Animal Health with no change in the payment limit of \$700,000 to procure medical and shelter supplies and to extend the term from December 30, 2016 through September 30, 2017.

**FISCAL IMPACT:**

No fiscal impact

**BACKGROUND:**

MWI Animal Health has provided medical and shelter supplies for Animal Services Department since 2014. MWI has been the sole source provider for Animal Services veterinarian and husbandry service supplies and equipment. The previous amendment to this contract increased the payment limit and extended the term. However, this amendment further extends the term, and allows the department to continue receiving supplies from MWI Animal Health through September 30, 2017.

**CONSEQUENCE OF NEGATIVE ACTION:**

Contra Costa's Animal shelter will be unable to purchase the supplies necessary to provide for the animal's needs.

APPROVE

OTHER

RECOMMENDATION OF CNTY ADMINISTRATOR

RECOMMENDATION OF BOARD  
COMMITTEE

Action of Board On: 11/01/2016  APPROVED AS RECOMMENDED  OTHER

Clerks Notes:

**VOTE OF SUPERVISORS**

AYE: John Gioia, District I Supervisor  
Candace Andersen, District II Supervisor  
Mary N. Piepho, District III Supervisor  
Karen Mitchoff, District IV Supervisor  
Federal D. Glover, District V Supervisor

I hereby certify that this is a true and correct copy of an action taken and entered on the minutes of the Board of Supervisors on the date shown.

ATTESTED: November 1, 2016

David J. Twa, County Administrator and Clerk of the Board of Supervisors

By: Chris Heck, Deputy

Contact: (925) 335-8370

cc:

CHILDREN'S IMPACT STATEMENT:

None



Contra  
Costa  
County

To: Board of Supervisors  
From: David O. Livingston, Sheriff-Coroner  
Date: November 1, 2016

Subject: AtHoc Inc.

**RECOMMENDATION(S):**

APPROVE and AUTHORIZE the Sheriff-Coroner, or designee, to execute a contract with AtHoc Inc., in an amount not to exceed \$3,800,000 for the provision of proprietary software maintenance for the County's Community Warning System for the period of July 1, 2016 through June 30, 2021.

**FISCAL IMPACT:**

\$3,800,000. This contract is fully funded by the Certified Unified Program Administration (CUPA) with allocated business plan fees.

**BACKGROUND:**

AtHoc Inc., is a full-service alert and warning company specializing in fixed siren systems and emergency notification systems. Alerting Solutions, Inc., provides support for the Contra Costa County Community Warning System. The Contra Costa County Community Warning System consists of 25 separate and linked control centers, monitoring systems, and communication systems between emergency responders, sirens (40), and other alerting devices (700+), and automated links to radio and television stations serving the community.

The Public Protection Committee reviewed this item at its October 24, 2016 meeting and voted to forward to the Board as recommended by the Sheriff-Coroner.

APPROVE

OTHER

RECOMMENDATION OF CNTY  
ADMINISTRATOR

RECOMMENDATION OF BOARD  
COMMITTEE

Action of Board On: **11/01/2016**

APPROVED AS  
RECOMMENDED

OTHER

Clerks Notes:

**VOTE OF SUPERVISORS**

AYE: John Gioia, District I Supervisor  
Candace Andersen, District II  
Supervisor  
Mary N. Piepho, District III  
Supervisor  
Karen Mitchoff, District IV  
Supervisor  
Federal D. Glover, District V  
Supervisor

I hereby certify that this is a true and correct copy of an action taken and entered on the minutes of the Board of Supervisors on the date shown.

ATTESTED: November 1, 2016

David J. Twa, County Administrator and Clerk of the Board of Supervisors

By: Chris Heck, Deputy

Contact: Sandra Brown  
925-335-1553

cc:

CONSEQUENCE OF NEGATIVE ACTION:

The County's Community Warning System will not be properly maintained.

CHILDREN'S IMPACT STATEMENT:

No impact.





Contra  
Costa  
County

To: Board of Supervisors  
From: Ed Woo, Chief Information Officer  
Date: November 1, 2016

Subject: GrantStream Incorporated Master Services Contract

---

**RECOMMENDATION(S):**

APPROVE and AUTHORIZE the Chief Information Officer, or his designee, to execute a Master Services Agreement with GrantStream, Incorporated, in an amount not to exceed \$68,000 to replace the Department of Information Technology's current grant management software application with GrantStream's Benevity Software-as-a-Service grant management application, for the period November 1, 2016 through October 31, 2017.

**FISCAL IMPACT:**

\$68,000 (100% User Fees); the cost is budgeted under Org# 1580, Fiscal Year 16/17

**BACKGROUND:**

The County requires a more capable grant management system. The current in house developed application has limited capabilities and does not work with mobile computing devices. GrantStream's management system, Benevity, will allow us to reduce our manual processing of grant funds distribution. It will also provide us with better reporting and mobile computing capabilities.

In accordance with Administrative Bulletin No 611.0, County departments are required to obtain Board approval for single item purchases over \$100,000. The County Administrator's Office has reviewed this request and recommends approval.

APPROVE

OTHER

RECOMMENDATION OF CNTY  
ADMINISTRATOR

RECOMMENDATION OF BOARD  
COMMITTEE

---

Action of Board On: **11/01/2016**  APPROVED AS  
RECOMMENDED

OTHER

Clerks Notes:

**VOTE OF SUPERVISORS**

AYE: John Gioia, District I Supervisor  
Candace Andersen, District II  
Supervisor  
Mary N. Piepho, District III  
Supervisor  
Karen Mitchoff, District IV  
Supervisor  
Federal D. Glover, District V  
Supervisor

I hereby certify that this is a true and correct copy of an action taken and entered on the minutes of the Board of Supervisors on the date shown.

ATTESTED: November 1, 2016

David J. Twa, County Administrator and Clerk of the Board of Supervisors

By: Chris Heck, Deputy

Contact: Ed Woo (925) 383-2688

cc:

CONSEQUENCE OF NEGATIVE ACTION:

Implementing the Benevity application is needed to provide an efficient grant application, review, issuance, and reporting for the applicant and for the department. Being hosted, the department will save on the expense of an in house hosted system.



Contra  
Costa  
County

To: Board of Supervisors  
From: Linda Dippel, Child Support Services Director  
Date: November 1, 2016

Subject: Contract Extension with Robert Half for Temporary Help for IT Support

---

**RECOMMENDATION(S):**

APPROVE and AUTHORIZE the Director of Child Support Services, or designee, to execute a contract amendment with Robert Half International, Inc., to increase the total payment limit by \$60,000 to a new payment limit not to exceed \$136,000 to provide information technology (IT) professional staff on a temporary basis, and to extend the term from September 30, 2016 to December 31, 2016.

**FISCAL IMPACT:**

This cost would be funded by 66% Federal, 34% State allocations. This expense is a zero cost to the County General Fund.

**BACKGROUND:**

The Department of Child Support Services (DCSS) is in need of information technology (IT) professional staff on a temporary basis to cover vacant positions while the Department is actively recruiting permanent IT professionals. Temporary appointments will be for a specific, predetermined period of time.

**CONSEQUENCE OF NEGATIVE ACTION:**

The DCSS will be unable to provide timely IT services.

---

<input checked="" type="checkbox"/> APPROVE	<input type="checkbox"/> OTHER
<input checked="" type="checkbox"/> RECOMMENDATION OF CNTY ADMINISTRATOR	<input type="checkbox"/> RECOMMENDATION OF BOARD COMMITTEE

---

Action of Board On: **11/01/2016**  APPROVED AS  
RECOMMENDED  OTHER

Clerks Notes:

**VOTE OF SUPERVISORS**

AYE: John Gioia, District I Supervisor  
Candace Andersen, District II  
Supervisor  
Mary N. Piepho, District III  
Supervisor  
Karen Mitchoff, District IV  
Supervisor  
Federal D. Glover, District V  
Supervisor

I hereby certify that this is a true and correct copy of an action taken and entered on the minutes of the Board of Supervisors on the date shown.

ATTESTED: November 1, 2016

David J. Twa, County Administrator and Clerk of the Board of Supervisors

By: Chris Heck, Deputy

Contact: Sarah Bunnell,  
925-313-4433

cc:

CHILDREN'S IMPACT STATEMENT:

Approval of this action will help IT services in support of children.



Contra  
Costa  
County

To: Board of Supervisors  
From: John Kopchik, Director, Conservation & Development Department  
Date: November 1, 2016

Subject: CaliforniaFirst PACE Financing Program

**RECOMMENDATION(S):**

1. ADOPT Resolution No. 2016/581 to join the CaliforniaFirst Property Assessed Clean Energy (PACE) financing program.
2. AUTHORIZE the Conservation and Development Director, or designee, to execute the Operating Agreement with the California Statewide Communities Development Authority (CSCDA) to operate the CaliforniaFirst PACE financing program in the unincorporated area of Contra Costa County.
3. AUTHORIZE the Conservation and Development Director, or designee, to execute the Indemnification and Insurance Agreement with Renew Financial Group LLC to provide indemnification and insurance protection to the County related to the CaliforniaFirst PACE financing program.

**FISCAL IMPACT:**

There is no fiscal impact to the County associated with this item.

**BACKGROUND:**

California law allows cities, counties, and other authorized public agencies to establish voluntary financing districts to facilitate energy and water efficiency improvements to existing residential and commercial properties. Such financing is commonly referred to as Property Assessed Clean Energy (PACE) financing. Once established, property owners within the boundaries of such a district can voluntarily choose to enter into a contractual assessment and

APPROVE

OTHER

RECOMMENDATION OF CNTY  
ADMINISTRATOR

RECOMMENDATION OF BOARD  
COMMITTEE

Action of Board On: **11/01/2016**  APPROVED AS  
RECOMMENDED

OTHER

Clerks Notes:

**VOTE OF SUPERVISORS**

AYE: John Gioia, District I Supervisor  
Candace Andersen, District II Supervisor  
Mary N. Piepho, District III Supervisor  
Karen Mitchoff, District IV Supervisor  
Federal D. Glover, District V Supervisor

I hereby certify that this is a true and correct copy of an action taken and entered on the minutes of the Board of Supervisors on the date shown.

ATTESTED: November 1, 2016

David J. Twa, County Administrator and Clerk of the Board of Supervisors

By: June McHuen, Deputy

Contact: Jason Crapo,  
925-674-7722

cc:

## BACKGROUND: (CONT'D)

>

borrow funds from the district to make energy efficiency improvements. The assessment is then repaid in installments on the property tax bill. If the property owner were to default on the property taxes, the Treasurer-Tax Collector would have the authority to foreclose on the property to collect payment.

The California Statewide Communities Development Authority (CSCDA) is a Joint Powers Authority with the legal authority to establish PACE financing districts, and is the public agency sponsor of the CaliforniaFirst PACE financing program. Contra Costa County is a member of CSCDA. CSCDA contracts with the financial services firm Renew Financial Group LLC to administer day-to-day operations of the CaliforniaFirst program.

On June 16, 2015, the Board of Supervisors approved the recommendation of the Internal Operations Committee to direct the Department of Conservation and Development (DCD) to establish an application process and accept applications from PACE providers to operate within the unincorporated area of the county. The Board also approved the form of an Operating Agreement the County would require PACE providers to enter into with the County as a condition of operations. The purpose of the Operating Agreement is to protect the County and the general public from the potential costs and risk of PACE programs. The Operating Agreement requires PACE providers to participate in the State PACE Loss Reserve Program, disclose financial costs and risks to participating property owners, and indemnify the County from legal claims arising from the operation of PACE programs.

In July 2015, DCD received applications from two PACE programs: CaliforniaFirst and California HERO. Consistent with direction received from the Board, staff began a review of the application materials submitted by these two PACE programs.

On November 17, 2015, the Board of Supervisors approved an Operating Agreement with the Western Riverside Council of Governments (WRCOG) and adopted a resolution authorizing WRCOG to operate the California HERO PACE financing program within the unincorporated area of the county. The HERO program is now operating within the unincorporated area and is providing PACE financing to property owners to finance energy and water efficiency improvements to their property.

After several months of discussions in 2015 and early 2016, DCD and CSCDA reached an impasse in negotiations concerning an agreement to authorize CSCDA to operate the CaliforniaFirst program within the County's jurisdiction. The main obstacle to completing an agreement was CSCDA's decision not to provide full indemnification to the County for the operation of the CaliforniaFirst program.

In May 2016, the Internal Operations Committee of the Board of Supervisors heard a status report on PACE financing and directed DCD and County Counsel to attempt to resolve the impasse with CSCDA concerning the CaliforniaFirst program.

The recommended Operating Agreement and Indemnification and Insurance Agreement will satisfy the County's requirements and will enable CSCDA to operate the CaliforniaFirst program within the unincorporated area of the county. The Insurance Indemnification Agreement with Renew Financial Group LLC provides additional indemnification protection to the County that CSCDA did not agree to provide in the Operating Agreement.

## CONSEQUENCE OF NEGATIVE ACTION:

If the Board of Supervisors does not approve the recommended actions, the CaliforniaFirst PACE financing program will not be able to provide property owners in the unincorporated area of the county with financing for energy and water efficiency improvements to their property.

## AGENDA ATTACHMENTS

Resolution No. 2016/581

CSCDA Operating Agreement

Indemnification & Insurance  
MINUTES ATTACHMENTS  
Signed Resolution No. 2016/581

**THE BOARD OF SUPERVISORS OF CONTRA COSTA COUNTY, CALIFORNIA**  
**and for Special Districts, Agencies and Authorities Governed by the Board**

Adopted this Resolution on 11/01/2016 by the following vote:

		<b>John Gioia</b>
		<b>Candace Andersen</b>
<b>AYE:</b>	<input type="text" value="5"/>	<b>Mary N. Piepho</b>
		<b>Karen Mitchoff</b>
		<b>Federal D. Glover</b>
<b>NO:</b>	<input type="text"/>	
<b>ABSENT:</b>	<input type="text"/>	
<b>ABSTAIN:</b>	<input type="text"/>	
<b>RECUSE:</b>	<input type="text"/>	



**Resolution No. 2016/581**

**RESOLUTION OF THE BOARD OF SUPERVISORS OF THE COUNTY OF CONTRA COSTA CONSENTING TO THE INCLUSION OF PROPERTIES WITHIN THE UNINCORPORATED AREA OF THE COUNTY IN THE CSCDA OPEN PACE PROGRAM KNOWN AS THE CALIFORNIAFIRST PROGRAM; AUTHORIZING THE CALIFORNIA STATEWIDE COMMUNITIES DEVELOPMENT AUTHORITY TO ACCEPT APPLICATIONS FROM PROPERTY OWNERS, CONDUCT CONTRACTUAL ASSESSMENT PROCEEDINGS AND LEVY CONTRACTUAL ASSESSMENTS WITHIN THE UNINCORPORATED AREA OF THE COUNTY; AND AUTHORIZING RELATED ACTIONS**

**WHEREAS**, the California Statewide Communities Development Authority (CSCDA) is implementing Property Assessed Clean Energy (PACE) programs, which it has designated CSCDA Open PACE, consisting of PACE programs each administered by a separate program administrator (collectively with any successors, assigns, replacements or additions, the "Programs"), to allow the financing or refinancing of renewable energy, energy efficiency, water efficiency and seismic strengthening improvements, electric vehicle charging infrastructure and such other improvements, infrastructure or other work as may be authorized by law from time to time (collectively, the "Improvements") through the levy of contractual assessments pursuant to Chapter 29 of Division 7 of the Streets & Highways Code ("Chapter 29") within the counties and cities throughout the State of California that consent to the inclusion of properties within their respective territories in the Programs and the issuance of bonds from time to time; and

**WHEREAS**, the program administrators currently active in administering CSCDA Open PACE programs are the AllianceNRG Program (presently consisting of CounterPointe Energy Solutions LLC and Leidos Engineering , LLC), PACE Funding LLC, Renew Financial Group LLC, CleanFund Commercial PAC Capital and Spruce Finance and the Authority will notify the County in advance of any additions or changes; and

**WHEREAS**, Chapter 29 provides that assessments may be levied under its provisions only with the free and willing consent of the owner or owners of each lot or parcel on which an assessment is levied at the time the assessment is levied; and

**WHEREAS**, the County desires to allow the owners of property ("Participating Property Owners") within its jurisdiction to participate in the CaliforniaFirst PACE program administered by Renew Financial Group LLC and to allow the Authority to conduct assessment proceedings under Chapter 29 within its jurisdiction and to issue bonds to finance or refinance improvements; and

**WHEREAS**, the territory within which assessments may be levied for the CaliforniaFirst PACE program administered by Renew Financial Group LLC shall include all of the unincorporated area within the County's official boundaries; and

**WHEREAS**, the Authority will conduct all assessment proceedings under Chapter 29 for the Programs and issue any bonds issued in connection with the Programs; and

**WHEREAS**, the County will not be responsible for the conduct of any assessment proceedings; the levy of assessments; any required remedial action in the case of delinquencies in such assessment payments; or the issuance, sale, or administration of any bonds issued in connection with the Programs.

**NOW, THEREFORE, BE IT RESOLVED** by the Board of Supervisors of the County as follows:



Section 1. This Board of Supervisors hereby finds and declares that properties in the jurisdiction of the County will benefit from the availability of the CaliforniaFirst program within the jurisdiction of the County and, pursuant thereto, the conduct of special assessment proceedings by the Authority pursuant to Chapter 29 and the issuance of bonds to finance or refinance improvements. This resolution shall only authorize the PACE Program administered by Renew Financial Group LLC, known as the CaliforniaFirst Program, to be available within the unincorporated area of Contra Costa County. Other program administrators under the Open PACE program may be made available by the County by adoption of a separate authorizing resolution.

Section 2. In Connection with the CaliforniaFirst PACE program, the County hereby consents to the conduct of special assessment proceedings by the Authority pursuant to Chapter 29 on any property within the jurisdiction of the County and the issuance of bonds to finance or refinance Improvements; provided, that

1. The Participating Property Owners, who shall be the legal owners of such property, execute a contract pursuant to Chapter 29 and comply with other applicable provisions of California law in order to accomplish the valid levy of assessment; and
2. The County will not be responsible for the conduct of any assessment proceedings; the levy of assessments; any required remedial action in the case of delinquencies in such assessment payments; or the issuance, sale or administration of any bonds issues in connection with the Programs.

Section 3. The following staff persons, together with any other staff persons chosen by the Conservation and Development Director of the County from time to time, are hereby designated as the contact persons for the Authority in connection with the Programs: Jason Crapo, Deputy Director.

Section 4. The appropriate officials and staff of the County are hereby authorized and directed to execute and deliver such certificates, requisitions, agreements and related documents as are reasonably required by the Authority to implement the Programs.

Section 5. The Board of Supervisors hereby finds that adoption of this Resolution is not a "project" under the California Environmental Quality Act, because the Resolution is a government fiscal activity that does not involve any commitment to a specific project which may result in a potentially significant physical impact on the environment, as contemplated by Title 14, California Code of Regulations, Section 15378(b)(4).

Section 6. This Resolution shall take effect immediately upon its adoption. The Clerk of the Board of Supervisors is hereby authorized and directed to transmit a certified copy of this resolution to the Secretary of the Authority at: Secretary of the Board, California Statewide Communities Development Authority, 1400 K Street, Sacramento, CA 95814

I hereby certify that this is a true and correct copy of an action taken and entered on the minutes of the Board of Supervisors on the date shown.

**ATTESTED: November 1, 2016**

David J. Twa, County Administrator and Clerk of the Board of Supervisors

**Contact: Jason Crapo, 925-674-7722**

By: June McHuen, Deputy

**cc:**

**THE BOARD OF SUPERVISORS OF CONTRA COSTA COUNTY, CALIFORNIA**

**and for Special Districts, Agencies and Authorities Governed by the Board**

Adopted this Resolution on 11/01/2016 by the following vote:

**AYE:**  5  **John Gioia**  
 **Candace Andersen**  
 **Mary N. Piepho**  
 **Karen Mitchoff**  
 **Federal D. Glover**

**NO:**

**ABSENT:**

**ABSTAIN:**

**RECUSE:**



**Resolution No. 2016/581**

**RESOLUTION OF THE BOARD OF SUPERVISORS OF THE COUNTY OF CONTRA COSTA CONSENTING TO THE INCLUSION OF PROPERTIES WITHIN THE UNINCORPORATED AREA OF THE COUNTY IN THE CSCDA OPEN PACE PROGRAM KNOWN AS THE CALIFORNIAFIRST PROGRAM; AUTHORIZING THE CALIFORNIA STATEWIDE COMMUNITIES DEVELOPMENT AUTHORITY TO ACCEPT APPLICATIONS FROM PROPERTY OWNERS, CONDUCT CONTRACTUAL ASSESSMENT PROCEEDINGS AND LEVY CONTRACTUAL ASSESSMENTS WITHIN THE UNINCORPORATED AREA OF THE COUNTY; AND AUTHORIZING RELATED ACTIONS**

**WHEREAS**, the California Statewide Communities Development Authority (CSCDA) is implementing Property Assessed Clean Energy (PACE) programs, which it has designated CSCDA Open PACE, consisting of PACE programs each administered by a separate program administrator (collectively with any successors, assigns, replacements or additions, the "Programs"), to allow the financing or refinancing of renewable energy, energy efficiency, water efficiency and seismic strengthening improvements, electric vehicle charging infrastructure and such other improvements, infrastructure or other work as may be authorized by law from time to time (collectively, the "Improvements") through the levy of contractual assessments pursuant to Chapter 29 of Division 7 of the Streets & Highways Code ("Chapter 29") within the counties and cities throughout the State of California that consent to the inclusion of properties within their respective territories in the Programs and the issuance of bonds from time to time; and

**WHEREAS**, the program administrators currently active in administering CSCDA Open PACE programs are the AllianceNRG Program (presently consisting of CounterPointe Energy Solutions LLC and Leidos Engineering, LLC), PACE Funding LLC, Renew Financial Group LLC, CleanFund Commercial PAC Capital and Spruce Finance and the Authority will notify the County in advance of any additions or changes; and

**WHEREAS**, Chapter 29 provides that assessments may be levied under its provisions only with the free and willing consent of the owner or owners of each lot or parcel on which an assessment is levied at the time the assessment is levied; and

**WHEREAS**, the County desires to allow the owners of property ("Participating Property Owners") within its jurisdiction to participate in the CaliforniaFirst PACE program administered by Renew Financial Group LLC and to allow the Authority to conduct assessment proceedings under Chapter 29 within its jurisdiction and to issue bonds to finance or refinance improvements; and

**WHEREAS**, the territory within which assessments may be levied for the CaliforniaFirst PACE program administered by Renew Financial Group LLC shall include all of the unincorporated area within the County's official boundaries; and

**WHEREAS**, the Authority will conduct all assessment proceedings under Chapter 29 for the Programs and issue any bonds issued in connection with the Programs; and

**WHEREAS**, the County will not be responsible for the conduct of any assessment proceedings; the levy of assessments; any required remedial action in the case of delinquencies in such assessment payments; or the issuance, sale, or administration of any bonds issued in connection with the Programs.

**NOW, THEREFORE, BE IT RESOLVED** by the Board of Supervisors of the County as follows:

Section 1. This Board of Supervisors hereby finds and declares that properties in the jurisdiction of the County will benefit from the availability of the CaliforniaFirst program within the jurisdiction of the County and, pursuant thereto, the conduct of special assessment proceedings by the Authority pursuant to Chapter 29 and the issuance of bonds to finance or refinance improvements. This resolution shall only authorize the PACE Program administered by Renew Financial Group LLC, known as the CaliforniaFirst Program, to be available within the unincorporated area of Contra Costa County. Other program administrators under the Open PACE program may be made available by the County by adoption of a separate authorizing resolution.

Section 2. In Connection with the CaliforniaFirst PACE program, the County hereby consents to the conduct of special assessment proceedings by the Authority pursuant to Chapter 29 on any property within the jurisdiction of the County and the issuance of bonds to finance or refinance Improvements; provided, that

1. The Participating Property Owners, who shall be the legal owners of such property, execute a contract pursuant to Chapter 29 and comply with other applicable provisions of California law in order to accomplish the valid levy of assessment; and
2. The County will not be responsible for the conduct of any assessment proceedings; the levy of assessments; any required remedial action in the case of delinquencies in such assessment payments; or the issuance, sale or administration of any bonds issues in connection with the Programs.

Section 3. The following staff persons, together with any other staff persons chosen by the Conservation and Development Director of the County from time to time, are hereby designated as the contact persons for the Authority in connection with the Programs: Jason Crapo, Deputy Director.

Section 4. The appropriate officials and staff of the County are hereby authorized and directed to execute and deliver such certificates, requisitions, agreements and related documents as are reasonably required by the Authority to implement the Programs.

Section 5. The Board of Supervisors hereby finds that adoption of this Resolution is not a "project" under the California Environmental Quality Act, because the Resolution is a government fiscal activity that does not involve any commitment to a specific project which may result in a potentially significant physical impact on the environment, as contemplated by Title 14, California Code of Regulations, Section 15378(b)(4).

Section 6. This Resolution shall take effect immediately upon its adoption. The Clerk of the Board of Supervisors is hereby authorized and directed to transmit a certified copy of this resolution to the Secretary of the Authority at: Secretary of the Board, California Statewide Communities Development Authority, 1400 K Street, Sacramento, CA 95814

I hereby certify that this is a true and correct copy of an action taken and entered on the minutes of the Board of Supervisors on the date shown.

**ATTESTED: November 1, 2016**

David J. Twa, County Administrator and Clerk of the Board of Supervisors

By: June McHuen, Deputy

Contact: Jason Crapo, 925-674-7722

cc:

**OPERATING AGREEMENT BETWEEN  
CONTRA COSTA COUNTY AND PACE PROVIDER FOR  
PROPERTY ASSESSED CLEAN ENERGY (PACE) FINANCING**

This agreement ("Agreement"), dated as of \_\_\_\_\_, 2016 ("Effective Date"), is by and between Contra Costa County, a political subdivision of the State of California (the "County"), and the California Statewide Communities Development Authority, a California limited joint powers authority established pursuant to Chapter 5 of Division 7, Title 1 of the Government Code of the State of California (Section 6500 and following (the "PACE Provider").

RECITALS

A. Property Assessed Clean Energy (PACE) financing is a method of providing loans to property owners to finance permanent energy efficiency improvements on real property. A property owner who obtains a PACE loan repays the loan by entering into an agreement that allows an assessment to be levied on the property. These assessments are known as voluntary contractual assessments.

B. Voluntary contractual assessments that are utilized to finance the installation of energy efficiency improvements on real property are authorized by (1) the Improvement Act of 1911, as amended by AB 811 (Streets and Highways Code Section 5898.10 et seq.) ("Improvement Act") and (2) the Mello-Roos Community Facilities Act of 1982, as amended by SB 555 (Government Code Section 53311 et seq. ("Mello-Roos Act").

C. The PACE Provider is a joint exercise of powers authority that has created one or more PACE financing programs (each, a "PACE Program"). The PACE Provider has established one or more PACE Programs to allow the financing of certain renewable energy, energy efficiency and water efficiency improvements that are permanently affixed to real property through the levy of assessments voluntarily agreed to by property owners participating in a PACE Program. Under each PACE Program, the PACE Provider accepts applications from eligible property owners, conducts assessment proceedings, and levies assessments.

**NOW, THEREFORE**, in consideration of the foregoing recitals and the mutual covenants contained herein, the parties agree as follows:

AGREEMENT

1. Definitions. As used in this Agreement, the following terms have the following meanings:
  - a. "PACE Administrator" means each independent contractor of the PACE Provider that markets, administers and carries out a PACE Program on behalf of the PACE Provider.

- b. “Eligible Improvement” is a renewable energy improvement, energy efficiency improvement or other improvement authorized by the Improvement Act, the Mello-Roos Act or other state law pertaining to voluntary contractual assessments.
- c. “Non-residential Property” means a property with four or more residential units or any commercial, agricultural, or industrial property that is otherwise eligible for PACE Financing.
- d. “Participating Contractor” is any contractor that installs Eligible Improvements that are funded by a PACE Provider.
- e. “Program Participant” is a property owner who enters into a voluntary contractual assessment with the PACE Provider.
- f. “Property Assessed Clean Energy (PACE) Financing” is a means of financing Eligible Improvements as authorized by the Improvement Act, the Mello-Roos Act, or other state law pertaining to voluntary contractual assessments.
- g. “Residential Property” means a property with three or fewer residential units.
- h. “Value” means the greater of: (1) assessed value; or (2) fair market value, as determined either by an automated valuation model or an appraisal.

## 2. General Requirements.

- a. PACE Provider's Specified Services. The PACE Provider may offer and provide Property Assessed Clean Energy Financing to property owners in the unincorporated areas of the County. The PACE Provider is solely responsible for the formation, operation and administration of the PACE Program, including the conduct of assessment proceedings, the levy and collection of assessments, and the offer, sale and administration of any bonds issued by the PACE Provider on behalf of the PACE Program.
- b. Cooperation with County. The PACE Provider shall independently operate its program and cooperate with the County and County staff as described in this Agreement.
- c. Performance Standard. The PACE Provider shall provide PACE Financing in a manner consistent with the level of competency and standard of care normally observed by an organization providing PACE Financing pursuant to the Improvement Act or Mello-Roos Act.

### 3. Disclosure Requirements.

The PACE Provider shall require and ensure that each PACE Administrator does all of the following:

- a. Discloses in writing to potential Program Participants the financial risks associated with PACE Financing, including the risks associated with federal regulation and administration of mortgage financing and the position of the Federal Housing Finance Agency (FHFA) on PACE lending. The disclosure materials must include the disclosures contained in the Financing Application, which is attached and incorporated herein as Attachment A.
- b. Requires potential Program Participants to sign a written acknowledgment of the Federal Housing Finance Agency (FHFA) position on PACE liens.
- c. Requires Program Participants who own non-residential properties to obtain written consent to participate in the PACE Program from lenders who have made loans to the Program Participant where the property serves as security for the loan.
- d. Provides federal Truth in Lending Act disclosure details to the applicant specific to the requested amount of the financing. The details shall be provided to the applicant in the Financing Estimate, which is attached and incorporated herein as Attachment B, and in the "Agreement to Pay Assessment and Finance Improvements," which is attached and incorporated herein as Attachment C.
- e. Advises potential Program Participants of available state or federal rebate or incentive programs.
- f. Requires each Program Participant to obtain from the County all building permits for improvements.
- g. The PACE Administrator may recommend that property owners consult with a tax professional prior to claiming any tax deductions associated with the project.

### 4. Financial Requirements.

The PACE Provider shall require and ensure that each PACE Administrator does all of the following:

- a. Administers and reviews Program Participant eligibility and determines the Eligible Improvement costs to be financed.

- b. Establishes each PACE Program's own interest rates, payback terms and fees.
- c. Participates in the State of California's PACE Loss Reserve Program, administered by the California Alternative Energy and Advanced Transportation Financing Authority (CAEATFA), and provide evidence of current participation and copies of all application materials submitted to CAEATFA. If the State discontinues the PACE Loss Reserve Program, or if the County determines that the State's PACE Loss Reserve Program does not provide adequate coverage, then the County may terminate this Agreement unless the County is satisfied with coverage by an alternative loan loss reserve program.
- d. For residential properties, ensures that the loan amount to a Program Participant does not exceed 15% of the value of the property up to the first \$700,000 of the value of the property, and is for less than 10% of the remaining value of the property above \$700,000.
- e. Ensures that the combined amount of any loans existing prior to the proposed PACE lien and the amount of the PACE line itself, have an aggregate amount of no more than 95% of the value of the property, including all mortgage-related debt as determined as of the date the assessment contract is executed.
- f. Ensures that the total property taxes and assessments for each property that will have PACE Financing will not exceed 5% of the value of the property as determined as of the date the assessment contract is executed.
- g. Verifies that each Program Participant is current on all property taxes and has not made late payments in the past three years, and verify that each Program Participant has not filed for bankruptcy in the past three years.
- h. Coordinates with the Auditor-Controller's Office each year regarding delinquent assessments.

5. Reports.

For each property that has entered into a voluntary contractual assessment through the PACE Provider, the PACE Provider shall require and ensure that each PACE Administrator provides project information and data in an accessible electronic format to the County on a monthly and annual basis and upon request, including but not limited to the following:

- a. The Assessor's Parcel Number (APN) and property type (residential or non-residential) of the property.
- b. The amount of the contractual assessment.

- c. All installed Eligible Improvements financed through PACE Financing.
  - d. The solar STC-DC rating in watts or kilowatts of each Eligible Improvement.
  - e. The expected financial and energy savings associated with each Eligible Improvement.
  - f. For each property with a limited subordinate agreement, the effective date of that agreement.
6. Participating Contractor Obligations. The PACE Provider shall require and ensure that each PACE Administrator does all of the following:
- a. Requires and ensures that each Participating Contractor has all required California State License Board licenses and all other required State and County licenses.
  - b. Requires and ensures that each Participating Contractor's bonding is in good standing.
  - c. Requires and ensures that each Participating Contractor holds harmless, indemnifies and defends the County as set forth in Section 9 (c).
  - d. Requires and ensures that each Participating Contractor has insurance as required in Section 12 (b).
  - e. Requires and ensures that each Participating Contractor and their representatives, employees, and agents do not represent themselves as agents, representatives, contractors, subcontractors, or employees of the County or the Department of Conservation and Development or claim association or affiliation with the County or Department of Conservation and Development.
7. Agreement with County Auditor-Controller. The PACE Provider will enter into a separate agreement with the Contra Costa County Auditor-Controller for the administration of property tax assessments placed on properties through the PACE Financing program.
8. Agreement with Program Participant. Each voluntary contractual assessment between the PACE Provider and a Program Participant shall require the Program Participant to hold harmless, indemnify and defend the County, and release the County from liability, in accordance with the "Agreement to Pay Assessment and Finance Improvements," which is attached and incorporated herein as Attachment C. The terms set forth in Attachment C shall be incorporated into the PACE



Provider's voluntary contractual assessment with each Program Participant for PACE Financing.

9. Indemnification and Release.

a. Indemnification Obligation of the PACE Provider. To the fullest extent not prohibited by applicable law, the PACE Provider shall defend, indemnify, protect, save, and hold harmless the County, the County Auditor-Controller, the County Treasurer-Tax Collector, their respective employees, agents, attorneys, officers, divisions, related agencies and entities, affiliates, successors and assigns (collectively and individually the "Indemnitees"), from any and all claims, cost, loss, liability, expense, damages, or other injury, claim, action or proceeding (collectively "Liability") arising out of or connected with this Agreement or activities taken by the parties pursuant to this Agreement, including but not limited to the establishment, placement or collection of assessments on participating properties; and will make good to and reimburse Indemnitees for any expenditures, including reasonable attorney's fees, the Indemnitees may make by reason of such matters. If requested by any of the Indemnitees, the PACE Provider will defend any such suits at the sole cost and expense of the PACE Provider with counsel selected or approved by the Contra Costa County Counsel.

The PACE Provider's obligations under this section will exist regardless of concurrent negligence or willful misconduct on the part of any Indemnitee or any other person; provided, however, that the PACE Provider will not be required to indemnify Indemnitees for the proportion of Liability a court determines is attributable to the sole negligence or willful misconduct of the County, its governing body, officers or employees. This indemnification clause shall survive the termination or expiration of this Agreement.

b. PACE Provider's Release. To the fullest extent not prohibited by applicable law, the PACE Provider hereby releases and forever discharges the County, the County Auditor-Controller, the County Treasurer-Tax Collector, their respective employees, agents, attorneys, officers, divisions, related agencies and entities, affiliates, successors and assigns (collectively "Released Parties"), from any and all claims, cost, loss, liability, expense, damage (including consequential damages), or other injury, claim, action or proceeding (including without limitation, attorneys fees and expenses), which the PACE Provider now has or could assert in any manner arising out of or connected with this Agreement, the subject matter of this Agreement, or activities taken by the parties pursuant to this Agreement, including any claim, action or proceeding to attack, set aside, void, abrogate, rescind or annul this Agreement or the actions of either party under this Agreement. The PACE Provider knowingly waives the right to make any claim against the Released Parties for such damages and expressly waives all rights provided by section 1542 of the California Civil Code, which provides as follows:

“A GENERAL RELEASE DOES NOT EXTEND TO CLAIMS WHICH THE CREDITOR DOES NOT KNOW OR SUSPECT TO EXIST IN HIS OR HER FAVOR AT THE TIME OF EXECUTING THE RELEASE, WHICH IF KNOWN BY HIM OR HER MUST HAVE MATERIALLY AFFECTED HIS SETTLEMENT WITH THE DEBTOR.”

The rights and obligations contained in this paragraph will survive termination of this Agreement.

c. Indemnification and Release Obligations of Participating Contractors.

The PACE Provider shall require and ensure that each PACE Administrator requires and ensures that each Participating Contractor releases, defends, indemnifies, protects, saves, and holds harmless the County, the County Auditor-Controller, the County Treasurer-Tax Collector, their respective employees, agents, attorneys, officers, divisions, related agencies and entities, affiliates, successors and assigns, from any and all liability, claims, losses, costs, expenses, penalties, fines, forfeitures, judgments and damages, including attorneys' fees and costs, arising out of or connected with the Participating Contractor's actions under the PACE Program, including the installation of any Eligible Improvement.

10. Term of Agreement. The term of this Agreement shall be from the Effective Date until termination in accordance with the provisions of Section 11, Termination.

11. Termination.

- a. Termination without Cause. Notwithstanding any other provision of this Agreement, at any time and without cause, the County or PACE Provider shall have the right, in its sole discretion, to terminate this Agreement by giving 30 days' written notice to the other Party of this Agreement. This Agreement may be cancelled immediately by written mutual consent.
- b. Termination for Cause. Notwithstanding any other provision of this Agreement, if the PACE Provider fails to uphold any of its obligations under this Agreement, or otherwise violates any of the terms of this Agreement, the County may immediately terminate this Agreement by giving the PACE Provider written notice of such termination, stating the reason for termination.
- c. Discontinuation of PACE Program. Upon 24 hours' notice from the County, the PACE Provider shall immediately discontinue its residential PACE Program in the County's unincorporated area if the Federal Housing Finance Authority (FHFA) takes any action in California pertaining to PACE Financing, as it relates to Fannie Mae and Freddie Mac mortgages, that the County determines will create an undue liability to the County or Program Participants.

- d. Delivery of Data and Information upon Termination. In the event of termination and within 14 days following the date of termination, the PACE Provider must deliver to County all data and information for all properties with contractual assessments, as specified in Section 5, Reports.
- e. Effect of Termination. If the Board of Supervisors terminates this agreement pursuant to this Section 11, the PACE Provider may not solicit new assessment contracts within the unincorporated areas of the County.
- f. Upon termination of this Agreement or the discontinuance of the PACE Program, the PACE Provider shall continue to administer all voluntary assessment contracts that exist at the time of the termination.

## 12. Insurance.

- a. The PACE Provider shall maintain commercial general liability insurance, including contractual liability (or blanket contractual) coverage, owners' and contractors' protective coverage, and broad form property damage coverage, with a minimum of \$1 million per occurrence.
- b. The PACE Provider will ensure that the following insurance requirements are incorporated into all contracts entered into by the PACE Provider with each PACE Administrator and Participating Contractor, or their respective contractors, subcontractors or assigns, in connection with this Agreement: (1) each PACE Administrator and Participating Contractor must maintain workers' compensation insurance pursuant to state law; (2) each PACE Administrator and Participating Contractor must maintain commercial general liability insurance, including contractual liability (or blanket contractual) coverage, owners' and contractors' protective coverage, and broad form property damage coverage, with a minimum of \$1 million per occurrence; (3) each PACE Administrator and Participating Contractor must maintain vehicle liability insurance with a minimum combined single-limit coverage of \$500,000 per occurrence; and (4) each PACE Administrator shall maintain Professional Liability Errors and Omissions Insurance coverage at \$1,000,000 per occurrence or aggregate limit. Each PACE Administrator and Participating Contractor shall provide certificates of insurance to the County, copies of policies, or endorsements evidencing the above insurance coverage and requiring at least 30 days' written notice to the County of policy lapse, cancellation, or material change in coverage.

## 13. Miscellaneous Provisions.

- a. Independent Contractor Status. The parties intend that the PACE Provider, in implementing and operating the PACE Program, is an independent contractor, and that the PACE Provider will control the work and the manner in which it is performed. This Agreement is not to be construed to

create a relationship between the parties of agent, servant, employee, partnership, joint venture, or association. The PACE Provider is not a County employee. This Agreement does not give the PACE Provider any right to participate in any pension plan, workers' compensation plan, insurance, bonus, or similar benefits County provides to its employees.

- b. Compliance with the Law. The PACE Provider is subject to and must comply with all applicable federal, state, and local laws and regulations with respect to its performance under this Agreement, including but not limited to, licensing, employment, and purchasing practices; and wages, hours, and conditions of employment, including nondiscrimination.
- c. Authorization. The PACE Provider represents and warrants that it has full power and authority to enter into this Agreement and to perform the obligations set forth herein.
- d. Assignment and Delegation. Neither party hereto shall assign, delegate, sublet, or transfer any interest in or duty under this Agreement without the prior written consent of the other, and no such transfer shall be of any force or effect whatsoever unless and until the other party shall have so consented. This Agreement binds the heirs, successors, assigns and representatives of the PACE Provider.
- e. Method and Place of Giving Notice. All notices shall be made in writing and shall be given by personal delivery or by U.S. Mail or courier service. Notices shall be addressed as follows:

TO COUNTY:

Contra Costa County  
Department of Conservation and Development  
Deputy Director, Building Inspection Division  
30 Muir Road  
Martinez, CA 94553

TO PACE PROVIDER:

The effective date of notice is the date of deposit in the mail or other delivery, except that the effective date of notice to the County is the date of receipt by the Deputy Director, Building Inspection Division, Department of Conservation and Development. Changes may be made in the names and

addresses of the person to whom notices are to be given by giving notice pursuant to this paragraph.

- f. Inspection. Upon the County's request, the County or its designee shall have the right at reasonable times and intervals to inspect the PACE Provider's financial and program records at the premises of the PACE Provider and the PACE Administrator. The PACE Provider or the PACE Administrator shall maintain all PACE Program records for a period of four years following termination of the Agreement, and shall make them available for copying upon the County's request at the County's expense.
- g. No Waiver of Breach. The waiver by the County of any breach of any term or promise contained in this Agreement shall not be deemed to be a waiver of such term or provision or any subsequent breach of the same or any other term or promise contained in this Agreement.
- h. Construction. To the fullest extent allowed by law, the provisions of this Agreement shall be construed and given effect in a manner that avoids any violation of statute, ordinance, regulation, or law. The parties agree that in the event that any provision of this Agreement is held by a court of competent jurisdiction to be invalid, void, or unenforceable, the remainder of the provisions hereof shall remain in full force and effect and shall in no way be affected, impaired, or invalidated thereby. The PACE Provider and the County acknowledge that they have each contributed to the making of this Agreement and that, in the event of a dispute over the interpretation of this Agreement, the language of the Agreement will not be construed against one party in favor of the other.
- i. Consent. Wherever in this Agreement the consent or approval of one party is required to an act of the other party, such consent or approval shall not be unreasonably withheld or delayed.
- j. No Third Party Beneficiaries. Nothing contained in this Agreement shall be construed to create, and the parties do not intend to create, any rights in third parties.
- k. Choice of Law. This Agreement is made in Contra Costa County and is governed by, and must be construed in accordance with, the laws of the State of California.
- l. Captions. The captions in this Agreement are solely for convenience of reference. They are not a part of this Agreement and shall have no effect on its construction or interpretation.

- m. Survival of Terms. All express representations, waivers, indemnifications, and limitations of liability included in this Agreement will survive its completion, expiration or termination for any reason.
- n. Time of Essence. Time is and shall be of the essence of this Agreement and every provision hereof.
- o. Entire Agreement. This Agreement contains all the terms and conditions agreed upon by the parties. Except as expressly provided herein, no other understanding, oral or otherwise, regarding the subject matter of this Agreement will be deemed to exist or to bind any of the parties hereto.
- p. Duplicate Counterparts. This Agreement may be executed in duplicate counterparts. The Agreement shall be deemed executed when it has been signed by both parties.

IN WITNESS WHEREOF, the parties hereto have executed this Agreement as of the Effective Date.

PACE PROVIDER

CONTRA COSTA COUNTY

By: \_\_\_\_\_  
 Name: \_\_\_\_\_  
 Title: \_\_\_\_\_

By: \_\_\_\_\_  
 Name: \_\_\_\_\_  
 Title: \_\_\_\_\_

# Sample Financing Application

## Attachment A

## FINANCING APPLICATION

### Application Information

Application ID	Application Date	
----------------	------------------	--

### Property Information

Property Type		
Street Address		
City	State	Zip

### Contractor Information

Contractor-Install
  Self-Install

Company Name <i>(Not Applicable if Self Install)</i>		
Street Address		
City	State	Zip

### Owner Information

Owner Type	Is Primary Contact for Application?	
First Name	Last Name	SSN
Birth Date	Phone	Email
Mailing Street Address		
Mailing City	Mailing State	Mailing Zip

### Maximum Eligible Project Amount

The Maximum Eligible Project Amount is the highest possible project amount for which you qualify with CaliforniaFIRST financing. Below is a list of requested products you want to install. If your Total Project Amount increases, you may need to re-sign new Financing Documents.	
--	--



**Eligible Product(s)**

	Product Type	Requested Project Amount
<b>Total Project Amount</b>		

## FINANCING APPLICATION DISCLOSURE

Application ID:

Property Address:

Under the CaliforniaFIRST program (“Program”), the California Statewide Communities Development Authority (“CSCDA”) finances installation of renewable energy, energy efficiency and/or water efficiency products that are permanently fixed to real property (“Eligible Products”). Eligible Products will be financed by levying a contractual assessment and placing a lien on your real property. The assessment will be repaid by collecting payments through annual installments that will be included on your property tax bill, consistent with an assessment contract between CSCDA and the property owner(s) (“Assessment Contract”). As discussed below, these installments will include interest, fees, annual costs and other costs. The Program is administered by Renewable Financial Group LLC (“Program Administrator”). The Program Administrator manages the Program Call Center and daily activities of the Program.

All relevant information about the Program can be found in the CaliforniaFIRST Program Residential Property Owner Handbook (“Property Owner Handbook”) and is discussed below. The list of cities and counties participating in the Program (“Participating Communities”) is available on the Program website and in the Property Owner Handbook.

### Program Requirements and Terms

The following requirements and terms apply to the Program. By signing this application, you acknowledge these requirements and terms and certify that, to the best of your knowledge, all applicable requirements have been satisfied. To verify that certain requirements have been satisfied, you authorize the Program Administrator to obtain a credit report for the property owner(s) and/or trustee(s) whose social security numbers are provided on this application.

- 1) The property identified above (the “Property”) is within a Participating Community, is used for residential purposes, has three (3) units or fewer, and is not undergoing development.
- 2) There is at least 10% equity in the Property (in other words, mortgage-related debt is no more than 90% of the value of the Property). In addition, the amount financed under the Program is the lesser of \$200,000 or 15%<sup>1</sup> of the value of the Property and, when combined with any other debts or obligations secured by the Property, cannot exceed 100% of the value of the Property.<sup>2</sup>
- 3) Taxes on the Property must be current for the prior twelve (12) months and have not have been paid late more than once during the prior three (3) years (or since the purchase of the Property if owned by the current property owner(s) for less than 3 years). The Property is not subject to any current federal or state income tax liens, judgment liens, mechanic’s liens, similar involuntary liens, or other liens/judgments over \$1,000 in total.<sup>2</sup>
- 4) All debts and obligations secured by the Property must be current and no mortgage payment can have been more than thirty (30) days late during the previous twelve (12) months. There have been no notices of default or foreclosure filed against the Property within the last two (2) years (or since the purchase of the Property if owned by the current property owner(s) for less than 2 years). The Property cannot be an asset in a bankruptcy proceeding and property owner(s) have not been involved in a bankruptcy proceeding during the past two (2) years.<sup>2</sup>
- 5) The Property’s title is not subject to power of attorney, easements, or subordination agreements restricting authority of the property owner(s) to subject the Property to a PACE lien, other than issues related to standard mortgage loan agreements.
- 6) All owners of record of the Property have signed this application and all other required Program documentation.
- 7) The maximum term of the financing per Property is the lesser of a) the useful economic life of the greatest Eligible Product or approved Custom Product cost financed with respect to such Property and b) twenty-five (25) years.
- 8) The all in tax rate on the Property may not exceed 5% of the subject Property value.

---

<sup>1</sup> Note that 15% of Property Value is only available for the first \$700K of the property value, then 10% is applied.

<sup>2</sup> Additional underwriting criteria apply to properties within the City of San Diego and Unincorporated Contra Costa County. Full details provided in the [Property Owner Handbook](#).

- 9) State incentive and rebate programs are available and participating property owners must declare any rebates received for the project.

### Program Rates, Fees, and Costs

Below are the rates, fees and costs of the Program. For rates, fees and costs specific to your application please see the Assessment Contract and Financing Statement.

<b>RATES</b>	
<b>Fixed Interest Rate.</b> The rate will be set when the Assessment Contract is issued and will be locked for <b>90-120</b> days (depending on the Eligible Products being financed). Installation of the Eligible Products must be completed and a Completion Certificate must be submitted to CSCDA by this date or the interest rate may change.	<b>Set Daily.</b>
<b>Annual Percentage Rate (APR).</b> Interest and certain other costs over the Assessment term expressed as a rate. This is not your interest rate.	<b>Varies. Based on interest rate and other costs.</b>
<b>UPFRONT COSTS</b>	
<b>Program-Related Fees.</b> One-time charges. Includes program administration, origination, program sponsor, bond counsel, and tax administration.	<b>Not to exceed 6.40% of Assessment Amount</b>
<b>Lien Recording.</b> The amount charged by the government for recording notice documents relating to the assessment on the Property.	<b>Varies by county. Not to exceed \$100.</b>
<b>Reserve Fund.</b> One-time charge deposited into debt service reserve fund for bonds issued by CSCDA to finance projects in the Program.	<b>0.25% of Assessment Amount</b>
<b>CAEATFA PACE Loss Reserve Program.</b> One-time charge for participation in the CAEATFA PACE Loss Reserve Program.	<b>\$0</b>
<b>Foreclosure Expense Reserve Account.</b> One-time charge deposited into a reserve account that CSCDA will use to pay for the costs of foreclosing on the Property and other properties participating in the Program as a result of a delinquency in the payment of any Financing Installment or Administrative Expenses.	<b>Varies. Not to exceed \$10 per transaction.</b>
<b>Capitalized Interest.</b> A lump sum interest charge for the period prior to the first tax year in which payment is made.	<b>Varies based on when financing begins.</b>
<b>ANNUAL COSTS</b>	
<b>Estimated Administrative Expenses.</b> An annual charge that will change based on the costs of the Program.	<b>Varies by County. May be increased over time.</b>

### Additional Disclosures

The following describes some (but not all) characteristics and risks of participation in the Program as well as laws to which the Program is subject. Additional information regarding the Program is provided in the Assessment Contract and the other Program documents. The Program Administrator is committed to your understanding each of the items listed below before you enter into an Assessment Contract, and invites you to ask Program representatives any questions regarding these items or for copies of any document related to the Program.

- 1) **Existing Mortgage.** The Program establishes the manner by which CSCDA may finance, pursuant to Chapter 29 of Part 3 of Division 7 of the California Streets and Highways Code (commencing with Section 5898.10), the installation of Eligible Products. Eligible Products will be financed pursuant to an Assessment Contract between you and CSCDA. **BEFORE COMPLETING A PROGRAM APPLICATION, YOU SHOULD CAREFULLY REVIEW ANY MORTGAGE AGREEMENT(S) OR OTHER SECURITY INSTRUMENT(S) THAT AFFECT THE PROPERTY OR TO WHICH YOU AS THE PROPERTY OWNER ARE A PARTY. ENTERING INTO AN ASSESSMENT CONTRACT WITHOUT THE CONSENT OF YOUR EXISTING LENDER(S) COULD CONSTITUTE AN EVENT OF DEFAULT UNDER SUCH AGREEMENTS OR SECURITY INSTRUMENTS. DEFAULTING UNDER AN EXISTING MORTGAGE AGREEMENT OR SECURITY INSTRUMENT COULD HAVE SERIOUS CONSEQUENCES TO YOU, WHICH COULD INCLUDE THE ACCELERATION OF THE REPAYMENT OBLIGATIONS DUE UNDER SUCH AGREEMENT OR SECURITY INSTRUMENT. IN ADDITION, FANNIE MAE AND FREDDIE MAC, THE OWNER OF A SIGNIFICANT PORTION OF ALL HOME MORTGAGES, STATED THAT THEY WOULD NOT PURCHASE HOME LOANS WITH ASSESSMENTS SUCH AS THOSE OFFERED BY CSCDA. THIS MAY MEAN THAT PROPERTY OWNERS**



WHO SELL OR REFINANCE THEIR PROPERTY MAY BE REQUIRED TO PREPAY SUCH ASSESSMENTS, AND ANY ASSOCIATED PREPAYMENT PENALTIES, AT THE TIME THEY CLOSE THEIR SALE OR REFINANCING. RENEW FINANCIAL DOES NOT CHARGE A PERCENTAGE OF THE OUTSTANDING BALANCE TO THE PROPERTY OWNER AS A PENALTY BASED ON THE YEAR IN WHICH THEY MAKE A PREPAYMENT. HOWEVER, DEPENDING ON WHEN THE PREPAYMENT IS MADE, ACCRUED INTEREST UNTIL NEXT PAYMENT DATE TO BOND HOLDERS – TWICE A YEAR IN SEPTEMBER AND MARCH – MUST BE PAID AT TIME OF PREPAYMENT. If your lender requires an impound for your property taxes, you should notify the lender of the annual assessment payment amount so they can adjust your impound amount.

- 2) **Valuation Disclosure.** We will order an automated valuation of the Property. We will promptly give you a copy of this valuation, even if your financing does not close. You can pay for an additional appraisal for your own use and to establish the property value at your own cost.
- 3) **Foreclosure.** Not later than October 1 each year, CSCDA will determine whether any annual assessment obligation is not paid when due and will have the right and obligation to order that any such delinquent payment, penalties, interest, and associated costs be collected by an action brought in Superior Court to foreclose the lien of such delinquent assessment obligation in the manner provided and to the extent permitted by applicable law. By December 1 of the same year, CSCDA will initiate the order to foreclose.
- 4) **No Endorsement, Warranty or Liability.** CSCDA, purchasers of bonds issued by CSCDA, and the Program Administrator do not endorse any manufacturer, contractor, product, or system, or in any way warranty such equipment, installation, or the efficiency or production capability of any equipment. CSCDA, purchasers of bonds issued by CSCDA, and the Program Administrator make no representations and have no responsibility regarding the equipment and its installation, including the quality, safety, cost savings, efficiency or production capability of any equipment; or any compliance of the equipment or its installation with any applicable laws, regulations, codes, standards or requirements. Further, CSCDA, purchasers of bonds issued by CSCDA, and the Program Administrator shall not be in any way liable for any incidental or consequential damages resulting from the equipment or its installation.
- 5) **Validation.** The Program Administrator may validate that installed Eligible Products meet Program eligibility requirements including requiring the applicant to provide additional sales receipts, contractor invoices, serial numbers or other identifying details, portions of packages or stickers originally attached to the installed Eligible Products beyond what the Program already requires to be provided. The Program Administrator may also conduct an inspection to validate installation of Eligible Products at qualified locations. You, by submitting this application, consent to any such onsite validations, which shall be conducted during normal business hours following advance notice to you. By submitting this application, you also agree to sign the authorization form to participate in billing energy usage analysis to measure Program impact savings and participant satisfaction.
- 6) **Equal Credit Opportunity Act (ECOA).** The Federal Equal Credit Opportunity Act prohibits creditors from discriminating against credit applicants on the basis of race, color, religion, national origin, sex, marital status, age (provided that the applicant has the capacity to enter into a binding contract); because all or part of an applicant's income derives from any public assistance program; or because an applicant has in good faith exercised any right under the Consumer Credit Protection Act. The Federal Agency that administers compliance with this law concerning this creditor is the Federal Trade Commission, Equal Credit Opportunity, Washington, D.C. 20580.
- 7) **Fair Credit Reporting Act.** As part of assembling your Program application, CSCDA has requested a consumer report bearing on your credit worthiness, credit standing and credit capacity. This notice is given to you pursuant to the Fair Credit Reporting Act.
- 8) **Communications with Legal Advisers.** If you have any questions about any agreements or security instruments that affect the Property or to which you are a party, or about your authority to execute this application or enter into an Assessment Contract with CSCDA without the prior consent of your existing lender(s), we strongly encourage you to consult with your own legal counsel and your lender(s). Program staff cannot provide you with advice about existing agreements or security instruments.
- 9) **Monitoring and Recording Telephone Calls.** The Program Administrator may monitor or record telephone calls for security and customer service purposes. By applying for CaliforniaFIRST Financing, you consent to have any phone conversations with the Program Administrator recorded or monitored.
- 10) **Married Applicants.** A married applicant whose spouse does not have an ownership interest in the Property may apply for a separate account.

**THE HOUSING FINANCIAL DISCRIMINATION ACT OF 1977 FAIR LENDING NOTICE**

**IT IS ILLEGAL TO DISCRIMINATE IN THE PROVISION OF OR IN THE AVAILABILITY OF FINANCIAL ASSISTANCE BECAUSE OF THE CONSIDERATION OF:**

- 1) TRENDS, CHARACTERISTICS OR CONDITIONS IN THE NEIGHBORHOOD OR GEOGRAPHIC AREA SURROUNDING A HOUSING ACCOMMODATION, UNLESS THE FINANCIAL INSTITUTION CAN DEMONSTRATE IN THE PARTICULAR CASE THAT SUCH CONSIDERATION IS REQUIRED TO AVOID AN UNSAFE AND UNSOUND BUSINESS PRACTICE; OR**
- 2) RACE, COLOR, RELIGION, SEX, MARITAL STATUS, DOMESTIC PARTNERSHIP, NATIONAL ORIGIN OR ANCESTRY.**

**IT IS ILLEGAL TO CONSIDER THE RACIAL, ETHNIC, RELIGIOUS OR NATIONAL ORIGIN COMPOSITION OF A NEIGHBORHOOD OR GEOGRAPHIC AREA SURROUNDING A HOUSING ACCOMMODATION OR WHETHER OR NOT SUCH COMPOSITION IS UNDERGOING CHANGE, OR IS EXPECTED TO UNDERGO CHANGE, IN APPRAISING A HOUSING ACCOMMODATION OR IN DETERMINING WHETHER OR NOT, OR UNDER WHAT TERMS AND CONDITIONS, TO PROVIDE FINANCIAL ASSISTANCE.**

**THESE PROVISIONS GOVERN FINANCIAL ASSISTANCE FOR THE PURPOSE OF THE PURCHASE, CONSTRUCTION, REHABILITATION OR REFINANCING OF ONE- TO FOUR-UNIT FAMILY RESIDENCES OCCUPIED BY THE OWNER AND FOR THE PURPOSE OF THE HOME IMPROVEMENT OF ANY ONE- TO FOUR-UNIT FAMILY RESIDENCE.**

**IF YOU HAVE ANY QUESTIONS ABOUT YOUR RIGHTS, OR IF YOU WISH TO FILE A COMPLAINT, CONTACT THE MANAGEMENT OF THIS FINANCIAL INSTITUTION OR:**

**SECRETARY OF BUSINESS, TRANSPORTATION AND HOUSING  
980 9TH STREET, SUITE 2450  
SACRAMENTO, CALIFORNIA 95814**

**Property Owner Declaration and Signature(s)**

By signing this Application, I hereby declare under penalty of perjury under the laws of the State of California all of the following:

- 1) That the information provided in this Application is true and correct to the best of my knowledge as of the date set forth opposite my signature below and that I understand that any intentional or negligent misrepresentation(s) of the information contained in this Application may result in civil liability and/or criminal penalties including, but not limited to, imprisonment, liability for monetary damages to CSCDA, its agents, or successors and assigns, insurers and any other person who may suffer any loss due to reliance upon any misrepresentation which I have made in this Application, or both.
- 2) I have provided information to the Program Administrator regarding other PACE liens on the subject property, if applicable.
- 3) I have the authority to authorize the Program Administrator to obtain a credit report for each of the property owner(s) and/or trustee(s) whose social security number(s) is provided on this application.
- 4) I have the authority to authorize the Program Administrator to share relevant information on application and financing status with the contractor(s) indicated on this application. The Program Administrator will not share social security numbers with the contractor(s).
- 5) I understand that it is my responsibility to receive all necessary approvals from my homeowners' association and/or historical review board, as applicable to my Property and project.
- 6) I understand that it is my responsibility to receive, read and understand all documents regarding the Program, which, in addition to the information on the Program website, include without limitation the following:
  - a. Residential Property Owner Handbook;
  - b. Financing Application and Disclosure;
  - c. Assessment Contract;
  - d. Financing Statement;
  - e. Notice of Right to Cancel;
  - f. Electronic Record and Signature Disclosure;
  - g. Privacy Policy Notice;
  - h. Self-Install Agreement (if applicable);
  - i. Notice to Proceed; and
  - j. Completion Certificate.

- 7) I have had an opportunity to ask Program representatives and/or my legal counsel any questions I have regarding the documents listed above. I understand I will be asked to sign the Assessment Contract, among other documents, before receiving any funds.
- 8) I am applying to participate in the Program. I have the authority, without the consent of any third party, to execute and deliver this application, the Assessment Contract, and the various other documents and instruments referenced herein.
- 9) I understand that the financing provided pursuant to the Assessment Contract will be repayable through an assessment levied against the Property. I understand that a special priority assessment lien will be recorded by CSCDA against the Property in the office of the County Recorder of the County in which the Property is located upon execution of the Assessment Contract. The property tax bill for the Property will increase by the amount of installments sufficient to repay the assessment (with interest) and related administrative expenses. The Assessment Contract will specify the amount of the assessment and the assessment obligations (including principal, interest, and estimated administrative expenses) to be collected on the property tax bill for the Property each year during the assessment term specified in the Assessment Contract. The assessment obligations and any associated penalties will constitute a lien against the Property until they are paid. As with all tax and assessment liens, this lien will be senior to all existing and future private liens against the Property, including mortgages, deeds of trust and other security instruments.
- 10) I acknowledge receipt of a copy of The Housing Financial Discrimination Act of 1977 Fair Lending Notice.

I declare that: (i) I have the authority, without the consent of any third party which has not been previously obtained, to execute and deliver this application and attest to the accuracy of the information indicated in this application; (ii) I have received, read and understand the risks and characteristics of the Program described above; and (iii) I have been informed that I must take the sole responsibility to satisfy myself that executing the Assessment Contract, receiving financing for Eligible Products, and consenting to the assessment levied against the Property will not constitute a default under any other agreement or security instrument (including, specifically, the terms of any mortgage on the Property) which affects the Property or to which I am a party.

---

Date

## Sample Financing Estimate

### Attachment B

## FINANCING ESTIMATE

Save this Financing Estimate to compare with your final Assessment Contract Exhibit B statement.  
 Please see the CaliforniaFIRST Residential Program Handbook for more information.

**DATE ISSUED**  
**PROPERTY OWNERS**  
**MAILING ADDRESS**

**PROPERTY ADDRESS**

**TERM**  
**PURPOSE**  
**PRODUCT**  
**IDENTIFICATION #**  
**RATE LOCK**

NO  YES, until **Month, Day, Year**

*After the Expiration Deadline interest rates and closing costs can change.*

### Product and Costs

Cost of Improvements		<ul style="list-style-type: none"> <li>Product 1:</li> <li>Product 2:</li> </ul> <p><i>See Closing Costs Details on next page</i></p>
Upfront Costs		
Capitalized Interest		
Lien Recording Fees		
<b>Estimated Assessment Amount</b>		

### Terms

		Can this amount increase after closing?
Estimated Assessment Amount		NO
Interest Rate		NO
Estimated Annual Payment		YES <i>Annual Administrative Expenses are subject to change</i>
		Does the financing have these features?
Prepayment Penalty		NO*
Balloon Payment		NO

\* Renew Financial does not charge a percentage of the outstanding balance to the property owner as a penalty based on the year in which they make a prepayment. However, depending on when the prepayment is made, accrued interest until next payment date to bond holders – twice a year in September and March – must be paid at time of prepayment.

### Projected Payments

Annual Payment Calculation	Years 1-	
Principal and Interest		
Estimated Annual Administrative Expenses		<i>Annual Administrative Expenses are subject to change</i>
<b>Estimated Annual Payment</b>		



## Closing Cost Details

### Costs at Closing

Estimated Closing Costs		Includes \$ _____ in Upfront Costs + \$ _____ in Other Costs + \$ _____ in Capitalized Interest. <i>See Calculating Cash to Close summary for details.</i>
Estimated Cash to Close	\$0	<i>See Calculating Cash to Close summary for details.</i>

### Upfront Costs

<b>A. Upfront Costs</b>	
Application Fee	\$0
Program-Related Fees	
Reserve Fund Deposit	
<b>B. Services</b> \$0	
Appraisal Fee	\$0
Credit Report Fee	\$0
Tax Monitoring Fee	\$0
Tax Status Research Fee	\$0
Title- Title Search Fee	\$0
<b>C. TOTAL UPFRONT COSTS (A + B)</b>	

### Other Costs

<b>D. Recording Fees</b>	
County Lien Recording Fees	

### Capitalized Interest

<b>E. Capitalized Interest</b> <i>(from estimated close date to Initial Annual Payment)</i>	
--	--

### Total Closing Costs

<b>F. TOTAL CLOSING COSTS (C + D + E)</b>	
---	--

### Calculating Cash to Close

Total Closing Costs (F)	
Closing Costs Financed <i>(Paid from Total Assessment Amount)</i>	
Down Payment/Funds from Property Owner	\$0
Funds from Registered Contractor	\$0
Other Credits	\$0
<b>Estimated Cash to Close</b>	<b>\$0</b>

### Summary

Assessment Obligations		<i>Total you will have paid in financing installments and annual administrative fees over the term.</i>
Annual Percentage Rate (APR)		<i>Your cost of funds over the term expressed as a rate. This is not your interest rate. This does not include tax savings, energy savings or prepayment assumptions.</i>
Total Interest		<i>The total amount of interest (including prepaid interest) that you will pay over the term.</i>

## Additional Information About This Financing

**PACE PROVIDER** Renew Financial Group LLC ("Renew Financial")  
**EMAIL** info@renewfinancial.com  
**PHONE** 844-RENEWFI (844-736-3934)

### Other Considerations

Home Sale or Refinancing	I UNDERSTAND that the CaliforniaFIRST Program is a long-term financing option for up to the life of the Improvements. The financing term for my project is # years. If I refinance my home, my mortgage company may require me to pay off the remaining balance. I understand that I may be required to pay off the remaining balance of this obligation by the mortgage lender refinancing my home. If I sell my home, the buyer or their mortgage lender may require me to pay off the balance of this obligation as a condition of sale.	
Monthly Mortgage Payments	I UNDERSTAND that my payments will be added to my property tax bill. I need to save an estimated \$ for my initial Annual Payment in the 2017-2018 tax year. If I pay my property taxes through my mortgage escrow or impound account, my monthly escrow payment should be adjusted to cover my increased property tax bill.	
Tax Benefits	I UNDERSTAND that I should consult my tax advisor regarding tax credits, credits and deductions, tax deductibility, and for other tax benefits of the CaliforniaFIRST Program, and I am responsible for submitting appropriate documentation with my tax return. I understand that it is my responsibility for making an appropriate application for the benefit.	
Three Day Right to Cancel	I UNDERSTAND that I may cancel the contract at any time prior to on or before midnight on the third business day after the date of the transaction to enter into the agreement without any penalty or obligation. To cancel this transaction, I may mail or deliver a signed and dated copy of the contract with notice of cancellation to: Renew Financial, 1620 E. Roseville Parkway Suite 240, Roseville, CA 95661. I may also cancel the contract by sending notification of cancellation by email to the following email address: info@californiafirst.org.	
Statutory Penalties	I UNDERSTAND that if my property tax payment is late, the amount due will be subject to a 10% penalty, late fees, and 1.5% per month interest penalty as established by state law, and my property may be subject to foreclosure.	

**Confirm Receipt**

By signing, you are only confirming that you have received and read this form, and it is NOT a contract. You do not have to accept this CaliforniaFIRST financing just because you have signed this form.

---

Date

## Sample Assessment Contract

### Attachment C

## AGREEMENT TO PAY ASSESSMENT AND FINANCE IMPROVEMENTS

### CALIFORNIA STATEWIDE COMMUNITIES DEVELOPMENT AUTHORITY CALIFORNIAFIRST (COUNTY OF CONTRA COSTA)

This AGREEMENT TO PAY ASSESSMENT AND FINANCE IMPROVEMENTS (this "**Agreement**") is made and entered into as of this **Month, Day, Year**, by and between the California Statewide Communities Development Authority, a joint exercise of powers authority (the "**Authority**"), and the record owner(s) (the "**Property Owner**") of the fee title to the real property identified on Exhibit A (the "**Property**").

#### RECITALS

**WHEREAS**, the Authority is a joint exercise of powers authority the members of which include numerous cities and counties in the State of California; and

**WHEREAS**, the Authority has established the CaliforniaFIRST program (the "**CaliforniaFIRST Program**") to allow the financing of certain renewable energy, energy efficiency and water efficiency improvements that are permanently fixed to real property (the "**Authorized Improvements**") through the levy of contractual assessments pursuant to Chapter 29 of Division 7 of the Streets & Highways Code ("**Chapter 29**") and the issuance of improvement bonds under the Improvement Bond Act of 1915 (Streets and Highways Code Sections 8500 and following) (the "**1915 Act**") upon the security of the unpaid contractual assessments; and

**WHEREAS**, Chapter 29 provides that assessments may be levied under its provisions only with the free and willing consent of the owner of each lot or parcel on which an assessment is levied at the time the assessment is levied pursuant to a contract between the property owner and the public agency; and

**WHEREAS**, the Authority has conducted the proceedings required by Chapter 29 with respect to the territory within the boundaries of the county identified on Exhibit A (the "**County**"); and

**WHEREAS**, the Property is located within the boundaries of unincorporated land of the County, or the incorporated city or city and county, identified in Exhibit A as the "Municipality" (the "**Municipality**"), and the Municipality has consented to (i) owners of property within its jurisdiction participating in the CaliforniaFIRST Program and (ii) the Authority conducting assessment proceedings under Chapter 29 and issuing bonds under the 1915 Act to finance the Authorized Improvements; and

**WHEREAS**, pursuant to Chapter 29, the Authority and the Property Owner wish to enter into a contract pursuant to which the Property Owner would agree to pay an assessment in order to finance the installation on the Property of the Authorized Improvements described on Exhibit A (the "**Improvements**") and the Authority would agree to provide financing, all on the terms set forth in this Agreement;

**NOW, THEREFORE**, in consideration of the foregoing and the material covenants hereinafter contained, the Property Owner and the Authority formally covenant, agree and bind themselves and their successors and assigns as follows:

## AGREEMENT

**Section 1. Purpose.** The Property Owner and the Authority are entering into this Agreement for the purpose of financing the installation of the Improvements identified on Exhibit A on the Property. The Authority will not finance installation of Improvements other than those listed on Exhibit A.

**Section 2. The Property.** This Agreement relates to the real property identified on Exhibit A. The Property Owner has supplied to the Authority current evidence of its ownership of fee title to the Property and possesses all legal authority necessary to execute this Agreement on behalf of the Property Owner.

**Section 3. Agreement to Pay Assessment; Prepayment.**

(a) **Payment of Assessment.** The Property Owner hereby freely and willingly agrees to pay the assessment shown as the “Assessment Amount” on Exhibit B, representing the amounts being financed (i) for purposes of installing the Improvements, which are shown as the “Cost of Improvements” in Exhibit B, and (ii) for the purposes described in Section 3(b) (the “**Assessment**”). The Authority will not provide financing for the benefit of the Property Owner in an amount in excess of the Assessment.

Except as otherwise set forth in this Agreement, the Assessment will be paid in the installments of principal (representing the amortization of the Assessment over the period shown on Exhibit B), except as provided in Section 3(b)(vi), and interest on the unpaid principal at the rate set forth on Exhibit B (collectively, the “**Financing Installments**”). Interest will begin to accrue on the date on which the Authority disburses money to the Property Owner, or its designee, to finance the installation of the Improvements. The interest rate is further described in Section 5(b) of this Agreement.

(b) **Financing of Upfront Costs.** In addition to financing installation of the Improvements, the Authority will finance the following amounts, which are included in the Assessment and shown as “Upfront Costs” on Exhibit B:

(i) **Program-Related Fees.** These include closing fees paid from a portion of bond proceeds to the Authority, any other entities responsible for program management and administration, and issuer and bond counsel to the Authority, and as well as any other related costs of issuance of any bond.

(ii) **Lien Recording Fee.** This one-time fee is paid from a portion of bond proceeds to cover the cost associated with recording the lien of the Assessment on the Property.

(iii) **Reserve Fund Deposit.** This is a one-time deposit from a portion of bond proceeds into a debt service reserve fund for bonds issued by the Authority to finance installation of the Improvements on the Property and other Properties participating in the CaliforniaFIRST Program.

(iv) California Alternative Energy and Advanced Transportation Financing Authority (“CAEATFA”) PACE Loss Reserve Program Fee. This is a one-time fee associated with the CAEATFA PACE Loss Reserve Program, which benefits any first mortgage lender on the Property and other Properties participating in the CaliforniaFIRST Program. The fee will be paid from a portion of bond proceeds.

(v) Foreclosure Expense Reserve Account Deposit. This is a one-time deposit from a portion of bond proceeds into a reserve account that the Authority will use to pay for the costs of foreclosing on the Property and other properties participating in the CaliforniaFIRST program as a result of a delinquency in the payment of any Financing Installment or Administrative Expenses.

(vi) Capitalized Interest. The Financing Installments and related Administrative Expenses may be billed either on or (to the extent permitted by law) off the County’s property tax roll at the sole discretion of the Authority. If on-roll billing is utilized, the CaliforniaFIRST Program’s deadline for placing the first year’s Financing Installment and related Administrative Expenses (as defined in Section 3(c)) on the County’s property tax roll is shown on Exhibit B as the “Applicable Tax Roll Deadline” (the “**Applicable Tax Roll Deadline**”). If the Authority issues a bond to finance installation of the Improvements on the Property before the Applicable Tax Roll Deadline occurring in the same calendar year of the bond issuance, then the first year’s Financing Installment and related Administrative Expenses will be billed on the Property Owner’s property tax bill for the related Tax Year (as defined in Section 5(c)). However, if the Authority issues such a bond after the Applicable Tax Roll Deadline occurring in the same calendar year of the bond issuance, the first year’s Financing Installment will not include a principal component, and a portion of the proceeds of the bond will be used to fund the payment of all of such year’s interest component.

(c) Administrative Expenses. The Property Owner hereby acknowledges that, pursuant to the 1915 Act (including Sections 8682(b) and 8682.1(a)), the Authority may add annual amounts to any Financing Installment in order to pay for the costs of collecting that installment and administering the CaliforniaFIRST Program (“**Administrative Expenses**”). Exhibit B shows the estimated Administrative Expenses with the Financing Installments; **however, such estimated Administrative Expenses may increase if the cost of collecting the Financing Installments or administering the CaliforniaFIRST Program increase.** The Property Owner agrees to pay actual Administrative Expenses, which may be higher than such estimates. The Administrative Expenses, together with each Financing Installment and the Assessment, are referred to collectively as the “**Assessment Obligations.**”

(d) Prepayment of the Assessment. The Assessment may be prepaid, in whole or any other amount of \$2500 or more, at any time. Prepayments will be applied at the end of the month in which funds are received. Upon request, the Authority will provide a payoff statement and payment instructions. The prepayment amount will include (i) a credit for any refund of capitalized interest, (ii) accrued interest that would otherwise accrue on the amount prepaid through the first bond interest payment date that is at least 65 days following the date of the prepayment and (iii) the reasonable costs of the Authority related to the prepayment. If Property Owner makes any prepayments, then on

or prior to June 30, the Authority will send an updated payment schedule that reduces subsequent annual installments so that the remaining scheduled payments will be sufficient to repay all amounts then due under the Assessment by the end of the original term of this Agreement. While the Property Owner will enjoy a lower annual installment following a partial prepayment, the total amount of interest Property Owner pays over the term of the Assessment will be higher than if Property Owner continued to pay annual installments of the original amount after a prepayment. Due to circumstances outside the Authority's control, prepayments made after June 30 of any calendar year may result in Property Owner receiving a tax bill that does not reflect that prepayment. In these circumstances, Property Owner must pay the full tax bill and the Authority will refund overpayments to Property Owner when the Authority receives the money from the tax collector.

(e) Absolute Obligation. The Property Owner hereby agrees that none of the Assessment Obligations will be subject to reduction, offset or credit of any kind in the event that the bonds secured thereby are refunded or for any other reason.

**Section 4.** Collection of Assessment; Lien. The Assessment Obligations, and the interest and penalties thereon imposed by law as a result of a delinquency in the payment of any Financing Installment and Administrative Expenses, shall constitute a lien against the Property until they are paid and shall be collected and have the lien priority set forth in Chapter 29.

The Property Owner acknowledges that if any Financing Installment and related Administrative Expenses are not paid when due, the Authority has the right to have the delinquent installment, associated penalties and interest stripped off the secured property tax roll and immediately enforced through a judicial foreclosure action that could result in a sale of the Property for the payment of the delinquent installment, associated penalties and interest, and all costs of suit, including attorneys' fees.

The Property Owner acknowledges that if bonds are sold to finance the Improvements, the Authority may obligate itself, through a covenant with the owners of the bonds, to exercise its foreclosure rights with respect to delinquent Financing Installments and related Administrative Expenses under specified circumstances. Such a covenant would typically provide that no later than a specific date in each year, the Authority will determine whether the Property is delinquent in the payment of Financing Installments and related Administrative Expenses and, if so, will notify its legal counsel ("**Authority Counsel**") of any such delinquencies. Authority Counsel will commence, or cause to be commenced, the foreclosure proceedings against the Property, including collection actions preparatory to the filing of any complaint, but will file the complaint by a specific date acceptable to the bond owner(s).

**Section 5.** Financing of the Improvements.

(a) Agreement to Finance Improvements. The Authority hereby agrees to use the Assessment to finance the Improvements, including the payment of the Authority's reasonable costs of administering the CaliforniaFIRST Program, subject to the Property Owner's compliance with the conditions for such financing established by the Authority. The Property Owner hereby acknowledges that the Improvements confer a special benefit to the Property in an amount at least equal to the Assessment.



(b) Financing Installments. The Property Owner agrees to the issuance of bonds by the Authority to finance the installation of the Improvements and other purposes described in Section 3(b). The interest rate used to calculate the interest component of the Financing Installments, as identified on Exhibit B, reflects the interest cost of the bonds. If the cost of the Improvements, as shown in a final invoice provided to the Authority by the Property Owner, is less than the amount shown on Exhibit B, then, concurrently with the disbursement of funds to the Property Owner, the Authority may provide the Property Owner with a schedule that provides for annual installments that are less than those set forth in the attached Exhibit B. The Property Owner hereby represents to the Authority that the cost of the Improvements as shown in a final invoice provided to the Authority by the Property Owner does not include any costs of constructing the Improvements for which the Property Owner will receive credits, incentives or rebates.

In the event the actual cost of acquisition, construction or installation of the Improvements exceeds the portion of the Assessment expected in this Agreement to be used to finance acquisition, construction and installation of the Improvements, then the Property Owner agrees to pay the additional costs and to complete acquisition, construction or installation of the Improvements.

(c) Initial Tax Year. The Financing Installments and related Administrative Expenses will be placed on the County property tax roll each “**Tax Year**” (being the period beginning July 1 and ending the immediately succeeding June 30), commencing with the first Tax Year in which the Financing Installments and related Administrative Expenses are placed on the Property Owner’s property tax bill prior to the Applicable Tax Roll Deadline for a Tax Year (the “**Initial Tax Year on Roll**”). The estimated Initial Tax Year on Roll is identified on Exhibit B.

**Section 6. Term; Agreement Runs with the Land; Subdivision.** (a) If the Authority has not received a completion certificate for the Improvements within 150 days of the date hereof, this Agreement shall automatically expire. The date of such expiration is shown as the “Expiration Date” on Exhibit B. Except as otherwise set forth in this Agreement, this Agreement shall also expire upon the final payment or prepayment of the Assessment Obligations. The Authority will notify the Property Owner in writing (at the address specified in Exhibit A) when the lien of the Assessment Obligations has been removed from the property.

(b) This Agreement establishes rights and obligations that are for the benefit of the Property and, therefore, such rights and obligations run with the land pursuant to Civil Code Section 1462.

(c) In the event the Property is subdivided while the Assessment Obligations remain unpaid, the Assessment Obligations will be assigned to the newly created parcel on which the Improvements are located. If the Improvements no longer exist, the Assessment Obligations will be assigned to each of the newly created parcels on a per-acre basis, unless the Authority, in its sole discretion, determines that the Assessment Obligations should be allocated in an alternate manner.

**Section 7. Recordation of Documents.** The Property Owner hereby authorizes and directs the Authority to cause to be recorded in the office of the County Recorder the various notices and other documents required by Chapter 29 and other

applicable laws to be recorded against the Property, including but not limited to the Notice of Assessment and the Payment of Contractual Assessment Required.

**Section 8. Notice.** To the extent required by applicable law, the Property Owner hereby agrees to provide written notice to any subsequent purchaser of the Property (including the purchasers of any subdivisions of the Property) of the obligation to pay the Assessment Obligations pursuant to this Agreement.

**Section 9. Waivers, Acknowledgment and Agreement.** Because this Agreement reflects the Property Owner's free and willing consent to pay the Assessment Obligations following a noticed public hearing, the Property Owner hereby waives any otherwise applicable requirements of Article XIID of the California Constitution or any other provision of California law for an engineer's report, notice, public hearing, protest or ballot.

The Property Owner acknowledges its right to cancel this transaction within three (3) business days from the date of its executing this Agreement.

The Property Owner hereby waives its right to repeal the Assessment Obligations by initiative or any other action, or to file any lawsuit or other proceeding to challenge the Assessment Obligations or any aspect of the proceedings of the Authority undertaken in connection with the CaliforniaFIRST Program. The Property Owner hereby agrees that the Property Owner and its successors in interest to fee title in the Property shall be solely responsible for the installation, operation and maintenance of the Improvements. The Property Owner hereby acknowledges that the Property will be responsible for payment of the Assessment Obligations regardless of whether the Improvements are properly installed, operated or maintained as expected.

The Property Owner hereby agrees that the Authority is entering into this Agreement solely for the purpose of assisting the Property Owner with the financing of the installation of the Improvements, and that any bond purchaser, the Authority and the city and county in which the Property is located have no responsibility of any kind for, and shall have no liability arising out of, the installation, operation, financing, refinancing or maintenance of the Improvements. Based upon the foregoing, the Property Owner hereby waives the right to recover from and fully and irrevocably releases any bond purchaser, the Authority, the city and county in which the Property is located and any and all agents, employees, attorneys, representatives and successors and assigns of the bond purchaser, the Authority and the city and county in which the Property is located from any and all losses, liabilities, claims, damages (including consequential damages), penalties, fines, forfeitures, costs and expenses (including all reasonable out-of-pocket litigation costs and reasonable attorney's fees), relating to the subject matter of this Agreement that the Property Owner may now have or hereafter acquire against the bond purchaser, the Authority, the city and county in which the Property is located and any and all agents, employees, attorneys, representatives and successors and assigns of the bond purchaser, the Authority or the city and county in which the Property is located.

To the extent that the foregoing waivers and agreements are subject to Section 1542 of the California Civil Code or similar provisions of other applicable law, it is the intention of the Property Owner that the foregoing waivers and agreements will be effective as a bar to any and all losses, liabilities, claims, damages (including

consequential damages), penalties, fines, forfeitures, costs and expenses (including all reasonable out-of-pocket litigation costs and reasonable attorney's fees), of whatever character, nature and kind, known or unknown, suspected or unsuspected, and Property Owner agrees to waive any and all rights and benefits conferred upon the Property Owner by the provisions of Section 1542 of the California Civil Code or similar provisions of applicable law. Section 1542 reads as follows:

"A GENERAL RELEASE DOES NOT EXTEND TO CLAIMS WHICH THE CREDITOR DOES NOT KNOW OR SUSPECT TO EXIST IN HIS OR HER FAVOR AT THE TIME OF EXECUTING THE RELEASE, WHICH IF KNOWN BY HIM OR HER MUST HAVE MATERIALLY AFFECTED HIS OR HER SETTLEMENT WITH THE DEBTOR."

By initialing below, the Property Owner agrees to waive the provisions of Section 1542 in connection with the matters that are the subject of the foregoing waivers and releases.

Property Owner's Initials:

\_\_\_\_\_

The waivers, releases and agreements set forth in this Section 9 shall survive termination of this Agreement.

**Section 10. Indemnification.** The Property Owner agrees to indemnify, defend, protect, and hold harmless the Authority, the city and county in which the Property is located, any bond purchaser and any and all agents, employees, attorneys, representatives and successors and assigns of the Authority, the city and county in which the Property is located or any bond purchaser, from and against all losses, liabilities, claims, damages (including consequential damages), penalties, fines, forfeitures, costs and expenses (including all reasonable out-of-pocket litigation costs and reasonable attorney's fees) and any demands of any nature whatsoever related directly or indirectly to, or arising out of or in connection with (i) the Property Owner's participation in the CaliforniaFIRST Program, (ii) the Assessment Obligations, (iii) the Improvements, or (iv) any other fact, circumstance or event related to the subject matter of this Agreement, regardless of whether such losses, liabilities, claims, damages (including consequential damages), penalties, fines, forfeitures, costs and expenses (including all reasonable out-of-pocket litigation costs and reasonable attorney's fees) accrue before or after the date of this Agreement.

The provisions of this Section 10 shall survive the termination or expiration of this Agreement.

**Section 11. Right to Inspect Property.** The Property Owner hereby grants the Authority and its agents and representatives the right to enter at any reasonable time, upon reasonable notice, to inspect the Improvements. The Property Owner further hereby grants the Authority and its agents and representatives the right to examine and copy any documentation relating to the Improvements.

**Section 12. Carbon Credits.** The Property Owner hereby agrees that any carbon credits or other similar environmental attributes that are attributable to the Improvements shall be owned by the Authority.

**Section 13. CaliforniaFIRST Application.** The Property Owner hereby represents and warrants to the Authority that the information set forth in the CaliforniaFIRST Program Application submitted to the Authority in connection with its request for financing is true and correct as of the date hereof, and that the representations set forth in the CaliforniaFIRST Program Application are true and correct as of the date hereof as if made on the date hereof.

**Section 14. Amendment.** Except as set forth in Section 5(b), this Agreement may be modified only by the written agreement of the Authority and the Property Owner.

**Section 15. Binding Effect; Assignment.** This Agreement inures to the benefit of and is binding upon the Authority, the Property Owner and their respective successors and assigns.

The Authority has the right to assign any or all of its rights and obligations under this Agreement without the consent of the Property Owner. The obligation to pay the Assessment Obligations set forth in this Agreement is an obligation of the Property, and no agreement or action of the Property Owner will be competent to impair in any way the Authority's rights, including, but not limited to, the right to pursue judicial foreclosure of the Assessment Obligations lien or the right to enforce the collection of the Assessment Obligations or any installment thereof against the Property.

**Section 16. Exhibits.** The Exhibits to this Agreement are incorporated into this Agreement by this reference as if set forth in their entirety in this Agreement.

**Section 17. Severability.** If any provision of this Agreement is held invalid or unenforceable by any court of competent jurisdiction, such holding will not invalidate or render unenforceable any other provision of this Agreement.

**Section 18. Corrective Instruments.** The Authority and the Property Owner agree that they will, from time to time, execute, acknowledge and deliver, or cause to be executed, acknowledged and delivered, such supplements hereto and such further instruments as may reasonably be required in order to carry out the expressed intention of this Agreement.

**Section 19. Governing Law; Venue.** This Agreement is governed by and construed in accordance with the laws of the State of California. Any legal action brought under this Agreement must be instituted in the Superior Court of the County of Sacramento, State of California; provided, however, that actions to foreclose delinquent Financing Installments and related Administrative Expenses will be instituted in the superior court of the County or as otherwise provided by law.

**Section 20. Existing Instruments.** BEFORE ENTERING INTO THIS ASSESSMENT CONTRACT, THE PROPERTY OWNER SHOULD CAREFULLY REVIEW ANY MORTGAGE AGREEMENT(S) OR OTHER SECURITY INSTRUMENT(S) ("EXISTING INSTRUMENTS") THAT AFFECT THE PROPERTY OR

TO WHICH THE PROPERTY OWNER IS A PARTY. THE PROPERTY OWNER'S ENTERING INTO THIS AGREEMENT WITHOUT THE CONSENT OF AN EXISTING LENDER COULD CONSTITUTE AN EVENT OF DEFAULT UNDER SUCH EXISTING INSTRUMENTS. DEFAULTING UNDER AN EXISTING INSTRUMENT COULD HAVE SERIOUS CONSEQUENCES TO THE PROPERTY OWNER, WHICH COULD INCLUDE THE ACCELERATION OF THE REPAYMENT OBLIGATIONS DUE UNDER SUCH INSTRUMENT. IN ADDITION, FANNIE MAE AND FREDDIE MAC, THE OWNER OF A SIGNIFICANT PORTION OF ALL HOME MORTGAGES, STATED THAT THEY WOULD NOT PURCHASE HOME LOANS WITH ASSESSMENTS SUCH AS THOSE OFFERED BY THE AUTHORITY. THIS MAY MEAN THAT PROPERTY OWNERS WHO SELL OR REFINANCE THEIR PROPERTY MAY BE REQUIRED TO PREPAY SUCH ASSESSMENTS AT THE TIME THEY CLOSE THEIR SALE OR REFINANCING.

**Section 21.** Counterparts. This Agreement may be executed in several counterparts, each of which is an original and all of which constitutes one and the same instrument.

IN WITNESS WHEREOF, the Authority and the Property Owner have caused this Agreement to be executed in their respective names by their duly authorized representatives, all as of the date first above written.

**CALIFORNIA STATEWIDE COMMUNITIES  
DEVELOPMENT AUTHORITY**

By: \_\_\_\_\_

Its: Authorized Signatory

The following are the authorized signatories of the Property Owner:

Name:
By: _____
Its: Authorized Signatory
Date: _____

**EXHIBIT A**  
**Description of the Property and Improvements**

Description of Property

Application ID:

Property Owner 1 Name:

Property Owner 2 Name:

Property Address:

County:

Municipality:

APN:

Property Legal  
Description:

Description of Improvements

Improvements owned by Property Owner(s)

Improvements owned by Third Party





**Assessment Terms:**

The schedule of the Financing Installments is based on the following assumptions:

Cost of Improvements	
Upfront Costs <ul style="list-style-type: none"><li>• Program-Related Fees pursuant to Section 3(b)(i)</li><li>• Lien Recording Fee pursuant to Section 3(b)(ii)</li><li>• Reserve Fund Deposit pursuant to Section 3(b)(iii)</li><li>• CAEATFA PACE Loss Reserve Program Fee pursuant to Section 3(b)(iv)</li><li>• Foreclosure Expense Reserve Account Deposit pursuant to Section 3(b)(v)</li><li>• Capitalized interest pursuant to Section 3(b)(vi)</li></ul>	
Applicable Tax Roll Deadline	
Initial Tax Year on Roll	
Interest rate used to calculate the interest component of the Financing Installments	
Annual Percentage Rate <sup>^</sup>	
Expiration Date	
Term of Assessment Obligations	

<sup>^</sup>The Annual Percentage Rate is interest and certain other costs over the term of the Assessment Obligations expressed as a rate. This is not your interest rate.

**INDEMNIFICATION AND INSURANCE AGREEMENT  
BY AND BETWEEN  
COUNTY of CONTRA COSTA  
AND  
RENEW FINANCIAL GROUP LLC**

This Indemnification and Insurance Agreement (the “Agreement”) is entered into by and between the County of Contra Costa, a political subdivision of the State of California (“County”), and Renew Financial Group LLC, a Delaware limited liability company (the “PACE Administrator”).

**RECITALS**

**WHEREAS**, the California Statewide Communities Development Authority (“Authority”) is a joint exercise of powers authority established pursuant to Chapter 5 of Division 7, Title 1 of the California Government Code; and

**WHEREAS**, the Authority established the CaliforniaFIRST Program (“PACE Program”) to allow the financing of certain renewable energy, energy efficiency and water efficiency improvements that are permanently affixed to real property through the levy of assessments voluntarily agreed to by participating property owners pursuant to Chapter 29 of Division 7 of the Streets and Highways Code (“Chapter 29”) and the issuance of improvement bonds under the Improvement Bond Act of 1915 upon the security of the unpaid assessments; and

**WHEREAS**, the Authority is responsible for the formation, operation and administration of the PACE Program as well as the sale and issuance of any bonds in connection therewith, including the conduct of assessment proceedings, the levy and collection of assessments and any remedial action in the case of such assessment payments, and the offer, sale and administration of any bonds issued by the Authority on behalf of the PACE Program; and

**WHEREAS**, the Authority has entered into a separate operating agreement with the County authorizing it to offer and provide the PACE Program in Contra Costa County; and

**WHEREAS**, the PACE Administrator is an independent contractor of the Authority that markets, administers, and carries out the PACE Program in Contra Costa County on behalf of the Authority.

NOW, THEREFORE, in consideration of the foregoing recitals and the mutual covenants contained herein, the parties agree as follows:

1. Agreement to Indemnify. To the fullest extent not prohibited by applicable law, the PACE Administrator shall defend, indemnify, protect, save, and hold harmless the County, the County Auditor-Controller, the County Treasurer-Tax Collector, their respective employees, agents, attorneys, officers, divisions, related agencies and entities, affiliates, successors and assigns (collectively and individually the

“Indemnitees”), from and against any and all claims, damages, losses, expenses, fines, penalties, judgments, demands and defense costs (including, without limitation, actual, direct, out-of-pocket costs and expenses and amounts paid in compromise or settlement and reasonable outside legal fees arising from litigation of every nature or liability of any kind or nature including civil, criminal, administrative or investigative) arising out of or in connection with the PACE Program. If requested by any of the Indemnitees, the PACE Administrator will defend any such suits at the sole cost and expense of the PACE Administrator with counsel approved by the Contra Costa County Counsel; provided, that if the Indemnitee does not request the PACE Administrator to defend such suit, then the Indemnitee shall consult with the PACE Administrator regarding the conduct of the defense and shall keep the PACE Administrator apprised of important developments related to the claim. The PACE Administrator’s obligations under this section will exist regardless of concurrent negligence or willful misconduct on the part of any Indemnitee or any other person; provided, however, that the PACE Administrator will not be required to indemnify Indemnitees for the proportion of liability a court determines is attributable to the sole negligence or willful misconduct of the County, its governing body, officers or employees. This indemnity shall apply to all claims and liability regardless of whether any insurance policies of the PACE Administrator, its affiliates or any other parties are applicable thereto. The policy limits of any insurance of the PACE Administrator, its affiliates or other parties are not a limitation upon the obligation of the PACE Administrator including without limitation the amount of indemnification to be provided by the PACE Administrator. This indemnification clause shall survive the termination or expiration of this Agreement.

2. Insurance. The PACE Administrator shall, at no cost or expense to the County and at all times during the operation of the PACE Program, maintain the insurance coverage set forth in Exhibit A to this Agreement.

3. Amendment/Interpretation of this Agreement. This Agreement, including all Exhibits attached hereto, represents the entire understanding of the parties as to those matters contained herein. No prior oral or written understanding shall be of any force or effect with respect to those matters covered hereunder. No supplement, modification or amendment of this Agreement shall be binding unless executed in writing by both of the parties hereto. This Agreement shall not be interpreted for or against any party by reason of the fact that such party may have drafted this Agreement or any of its provisions.

4. Section Headings. Section headings in this Agreement are included for convenience of reference only and shall not constitute a part of this Agreement for any other purpose.

5. Waiver. No waiver of any of the provisions of this Agreement shall be binding unless in the form of a writing signed by the party against whom enforcement is sought, and no such waiver shall operate as a waiver of any other provisions hereof (whether or not similar), nor shall such waiver constitute a continuing waiver. Except as specifically

provided herein, no failure to exercise or any delay in exercising any right or remedy hereunder shall constitute a waiver thereof.

6. Severability and Governing Law. If any provision or portion thereof of this Agreement shall be held by a court of competent jurisdiction to be invalid, void, or otherwise unenforceable, the remaining provisions shall remain enforceable to the fullest extent permitted by law. This Agreement shall be governed by and construed and enforced in accordance with the laws of the State of California applicable to contracts made and to be performed in California.

7. Notices. All notices, demands and other communications required or permitted hereunder shall be made in writing and shall be deemed to have been duly given if delivered by hand, against receipt, or mailed certified or registered mail and addressed as follows:

If to the PACE Administrator

Renew Financial Group LLC  
1221 Broadway, 4<sup>th</sup> Floor  
Oakland, CA 94612

If to the County:

County of Contra Costa  
Attn: Jason Crapo, Deputy Director  
Dept. of Conservation and Development  
30 Muir Rd.  
Martinez, CA 94553

8. Counterparts. This Agreement may be executed in one or more counterparts, each of which shall be deemed to be an original, which together shall constitute the same instrument.

9. Successors and Assigns. This Agreement shall apply to, bind and inure to the benefit of successors in interest of the parties hereto, including heirs, assigns, executors, administrators and all other parties, whether they succeed by operation of law or voluntary acts.

10. No Third-Party Beneficiaries. Nothing in this Agreement shall be construed to create, and the parties do not intend to create, any rights in third parties.

11. Effective Date. This Agreement will be effective as of the date of the signature of County's representative as indicated below in the County's signature block.

IN WITNESS HEREOF, the parties hereto duly executed this Agreement as of the date below.

“County”

County of Contra Costa, a political  
subdivision of the State of California

By \_\_\_\_\_

Date: \_\_\_\_\_

“PACE Administrator”

Renew Financial Group LLC

By \_\_\_\_\_

Name:

Title:

Date: \_\_\_\_\_

**EXHIBIT A**  
**INSURANCE**

**A. Minimum Scope of Insurance**

Coverage shall be at least as broad as:

1. The coverage provided by Insurance Services Office Commercial General Liability coverage (“occurrence”) Form Number CG 0001; and
2. The coverage provided by Insurance Services Office Form Number CA 0001 covering Automobile Liability. Coverage shall be included for all owned, non-owned and hired automobiles; and
3. Workers' Compensation insurance as required by the California Labor Code and Employers Liability insurance; and
4. Professional Liability Errors & Omissions for all professional services.

There shall be no endorsement reducing the scope of coverage required above unless approved by the County’s Risk Manager.

**B. Minimum Limits of Insurance**

PACE Administrator shall maintain limits no less than:

1. Commercial General Liability: \$1,000,000 per occurrence for bodily injury, personal injury and property damage. If Commercial Liability Insurance or other form with a general aggregate limit is used, either the general aggregate limit shall apply separately to this project/location or the general aggregate limit shall be twice the required occurrence limit; and
2. Automobile Liability: \$1,000,000 combined single limit per accident for bodily injury and property damage; and
3. Workers' Compensation and Employers Liability: Workers' Compensation limits as required by the California Labor Code and Employers Liability limits of \$1,000,000 per accident; and
4. Professional Liability Errors & Omissions \$1,000,000 per occurrence/ aggregate limit.

### **C. Deductibles and Self-Insured Retentions**

PACE Administrator shall maintain the following deductibles on its insurance policies:

- Property: \$2,500
- General Liability: \$0
- Professional Liability: \$250,000

### **D. Other Insurance Provisions**

The policies are to contain, or be endorsed to contain, the following provisions:

1. Commercial General Liability and Automobile Liability Coverages
  - a. County of Contra Costa, its officers, employees, agents and contractors are to be covered as additional insureds as respects: Liability arising out of activities performed by or on behalf of, PACE Administrator; products and completed operations of PACE Administrator; premises owned, leased or used by PACE Administrator; and automobiles owned, leased, hired or borrowed by PACE Administrator. The coverage shall contain no special limitations on the scope of protection afforded to County, its officers, employees, agents and contractors.
  - b. PACE Administrator's insurance coverage shall be primary insurance as respects County, its officers, employees, agents and contractors. Any insurance or self-insurance maintained by County, its officers, employees, agents or contractors shall be excess of PACE Administrator's insurance and shall not contribute with it.
  - c. Any failure to comply with reporting provisions of the policies by PACE Administrator shall not affect coverage provided County, its officers, employees, agents, or contractors.
  - d. Coverage shall state that PACE Administrator's insurance shall apply separately to each insured against whom claim is made or suit is brought, except with respect to the limits of the insurer's liability.
  - e. Coverage shall contain a waiver of subrogation in favor of the County, its officers, employees, agents and contractors.
2. Workers' Compensation and Employers' Liability

Coverage shall contain waiver of subrogation in favor of County of Contra Costa, its officers, employees, agents and contractors.

### 3. All Coverages

Each insurance policy required by this AGREEMENT shall be endorsed to state that coverage shall not be suspended, voided, cancelled, or reduced in limits except after thirty (30) days' prior written notice has been given to County, except that ten (10) days' prior written notice shall apply in the event of cancellation for nonpayment of premium; provided, that if such endorsement is not commercially available, PACE Administrator agrees to provide County such notice.

#### **E. Acceptability of Insurers**

Insurance is to be placed with insurers acceptable to County's Risk Manager.

#### **F. Verification of Coverage**

PACE Administrator shall furnish County with certificates of insurance and with original endorsements affecting coverage required by this AGREEMENT. The certificates and endorsements for each insurance policy are to be signed by a person authorized by that insurer to bind coverage on its behalf.

Proof of insurance shall be either emailed in pdf format to: [jason.crapo@dcd.cccounty.us](mailto:jason.crapo@dcd.cccounty.us), or mailed to the following postal address or any subsequent address as may be directed in writing by the County Department of Conservation and Development:

County of Contra Costa  
Jason Crapo, Deputy Director  
Department of Conservation and Development  
30 Muir Rd.  
Martinez, CA 94553

#### **G. Subcontractors**

PACE Administrator shall include all subcontractors as insureds under its policies or shall obtain separate certificates and endorsements for each subcontractor.





Contra  
Costa  
County

To: Board of Supervisors  
From: Russell Watts, Treasurer-Tax Collector  
Date: November 1, 2016

Subject: Sale of Tax-Defaulted Property by the County Tax Collector

---

**RECOMMENDATION(S):**

ADOPT Resolution No. 2016/614 authorizing the sale of specified tax-defaulted property at public auction, pursuant to the California Revenue and Taxation Code ("R&T") §3698, as recommended by the Treasurer-Tax Collector.

**FISCAL IMPACT:**

There is no impact to the General Fund. All costs will be recovered from the proceeds of the sale. Property or property interests that have been offered for sale at least once and where no acceptable bids have been received at the minimum price, the tax collector may offer that same property or those interests at the same or next scheduled sale at a minimum price that may be less than the amount of defaulted taxes, delinquent and redemption penalties as specified in R&T §3698.5(a)(1). Should the final selling price at public auction be less than the amount as specified in R&T §3698.5(a)(1), proceeds shall be distributed as specified in R&T §4673.1 & R&T §4674 and any remaining balance to satisfy the amounts as specified in R&T §3698.5(a)(1) may be transferred from the Tax Loss Reserve Fund. (R&T § 4703.2(c).)

APPROVE

OTHER

RECOMMENDATION OF CNTY ADMINISTRATOR

RECOMMENDATION OF BOARD  
COMMITTEE

Action of Board On: **11/01/2016**  APPROVED AS RECOMMENDED  OTHER

Clerks Notes:

**VOTE OF SUPERVISORS**

AYE: John Gioia, District I Supervisor  
Candace Andersen, District II Supervisor  
Mary N. Piepho, District III Supervisor  
Karen Mitchoff, District IV Supervisor  
Federal D. Glover, District V Supervisor

I hereby certify that this is a true and correct copy of an action taken and entered on the minutes of the Board of Supervisors on the date shown.

ATTESTED: November 1, 2016

David J. Twa, County Administrator and Clerk of the Board of Supervisors

By: June McHuen, Deputy

Contact: Brice Bins, 957-2848

cc: Brice Bins, Chief Deputy Treasurer-Tax Collector

BACKGROUND:

The Tax Collector has the authority to sell tax-defaulted property that is subject to the power of sale (R&T §3691). Written approval of the Board of Supervisors (R&T § 3694 and 3698) is required to sell property at public auction (R&T §3692) to the highest bidder at the time and place fixed for sale (R&T §3706)

Property that has been tax-defaulted for five or more years and is subject to the Tax Collector's power to sell may be sold. All or any portion of a property may be offered for sale, without regard to its boundaries when it became subject to sale (R&T §3691).

The purpose of the sale is to collect unpaid taxes. Offering property for sale achieves this, either by collecting the unpaid taxes from the proceeds of the sale or through redemption by the assessee.

Any person or entity, including cities, taxing agencies, revenue districts and the State may purchase property at a public auction (R&T § 3691 and 3705). The only exception to eligible purchasers is the Tax Collector, who conducts the sale, or his/her employees (California Government Code § 1090).

If a parcel is redeemed before the close of business on the last business day prior to the date of sale, the power to sell is automatically nullified and the parcel will be withdrawn from the sale. If a parcel is redeemed within 90 days of the scheduled sale, \$150 will be collected to reimburse the County for costs incurred in preparing to conduct the sale (R&T § 4112). Where property or property interests have been offered for sale at least once and no acceptable bids therefor have been received at the minimum price, the tax collector may, in his or her discretion and with the approval of the board of supervisors, offer that same property or those interests at the same or next scheduled sale at a minimum price that the tax collector deems appropriate in light of the most current assessed valuation of that property or those interests, or any unique circumstance with respect to that property or those interests. (R&T § 3698.5(c)) Any parcel remaining unsold may be reoffered within a 90-day period and any new parties of interest shall be notified in accordance with R&T §3706.

CONSEQUENCE OF NEGATIVE ACTION:

If not approved, the Annual Tax Collector's Public Auction will not proceed and property taxes will not be collected.

AGENDA ATTACHMENTS

Resolution No. 2016/614

Exhibit A

MINUTES ATTACHMENTS

Signed Resolution No. 2016/614

**THE BOARD OF SUPERVISORS OF CONTRA COSTA COUNTY, CALIFORNIA**  
**and for Special Districts, Agencies and Authorities Governed by the Board**

Adopted this Resolution on 11/01/2016 by the following vote:

		<b>John Gioia</b>
		<b>Candace Andersen</b>
<b>AYE:</b>	<input type="text" value="5"/>	<b>Mary N. Piepho</b>
		<b>Karen Mitchoff</b>
		<b>Federal D. Glover</b>
<b>NO:</b>	<input type="text"/>	
<b>ABSENT:</b>	<input type="text"/>	
<b>ABSTAIN:</b>	<input type="text"/>	
<b>RECUSE:</b>	<input type="text"/>	



**Resolution No. 2016/614**

In The Matter Of the Sale of Tax-Defaulted Property by the County Tax Collector

Whereas, the Board, pursuant to §3698 of the Revenue and Taxation code, having been notified by the County Tax Collector of his intent to sell certain tax-defaulted property at public auction and having been provided with a description and minimum purchase price for which each will be sold, and the notice of intended sale of the aforementioned properties be posted or published in accordance with §3702 and §3703 of the California Revenue and Taxation Code.

Now, Therefore, Be It Resolved by the Board that the County Tax Collector's proposed sale of tax-defaulted properties listed in Exhibit A attached hereto and made a part hereof, at or above the minimum price indicated is APPROVED pursuant to §3698 of the Revenue and Taxation Code, and the notice of intended sale be posted or published in accordance with §3702 and §3703 of the Revenue and Taxation Code.

I hereby certify that this is a true and correct copy of an action taken and entered on the minutes of the Board of Supervisors on the date shown.

**Contact: Brice Bins, 957-2848**

**ATTESTED: November 1, 2016**

David J. Twa, County Administrator and Clerk of the Board of Supervisors

By: June McHuen, Deputy

**cc:** Brice Bins, Chief Deputy Treasurer-Tax Collector

**THE BOARD OF SUPERVISORS OF CONTRA COSTA COUNTY, CALIFORNIA**

**and for Special Districts, Agencies and Authorities Governed by the Board**

Adopted this Resolution on 11/01/2016 by the following vote:

**John Gioia**  
**Candace Andersen**  
**Mary N. Piepho**  
**Karen Mitchoff**  
**Federal D. Glover**

AYE:  5

NO:

ABSENT:

ABSTAIN:

RECUSE:



**Resolution No. 2016/614**

In The Matter Of the Sale of Tax-Defaulted Property by the County Tax Collector

Whereas, the Board, pursuant to §3698 of the Revenue and Taxation code, having been notified by the County Tax Collector of his intent to sell certain tax-defaulted property at public auction and having been provided with a description and minimum purchase price for which each will be sold, and the notice of intended sale of the aforementioned properties be posted or published in accordance with §3702 and §3703 of the California Revenue and Taxation Code.

Now, Therefore, Be It Resolved by the Board that the County Tax Collector's proposed sale of tax-defaulted properties listed in Exhibit A attached hereto and made a part hereof, at or above the minimum price indicated is APPROVED pursuant to §3698 of the Revenue and Taxation Code, and the notice of intended sale be posted or published in accordance with §3702 and §3703 of the Revenue and Taxation Code.

I hereby certify that this is a true and correct copy of an action taken and entered on the minutes of the Board of Supervisors on the date shown.

**ATTESTED: November 1, 2016**

David J. Twa, County Administrator and Clerk of the Board of Supervisors

By: June McHuen, Deputy

Contact: Brice Bins, 957-2848

cc: Brice Bins, Chief Deputy Treasurer-Tax Collector



THE PROPERTY LISTED BELOW WAS OFFERED FOR SALE AT PUBLIC AUCTION ENDING ON FEBRUARY 21, 2017, AND WAS DISPOSED OF AS FOLLOWS:																								
WITH APPROVAL OF THE BOARD OF SUPERVISORS, BY RESOLUTION 2016/10, DATED NOVEMBER 1, 2016.																								
ITEM #	Assessor's Parcel Number (APN)	Mn Bldg	Default # Notice Rec.	Sales Price	Transfer Tax (City)	Transfer Tax (State)	State Fee	Advt Rec Fee	Notes	Costs borne by the Delinquent Owner										Redemp Amount	Current Taxes	Excess Proceeds	Purchaser Name	Deed # & Date
										Adv	BIA	Title	County	Contact	Big Cost	TOTAL								
85	LAURA MICHELI 354-142-011-7		22,100	2009-08500																				
86	JACQUELYNE CAESAR 354-151-011-5		46,800	2016-016292																				
87	MIKE ROWLAND LAURA MICHELI 380-180-068-5		66,900	2009-09082																				
88	KENT SALLY MCKAY WITHERAWAN			2016-016294																				
89	409-240-029-2		12,400	2009-09886																				
90	IRVING STUART		13,200	2016-016767																				
91	IRVING STUART		13,200	2009-09897																				
92	018-260-023-3		125,000	2010-06533																				
93	FIRST UNITED PENTECOSTAL CH		11,800	2014-0166346																				
94	098-500-068-8			2010-06672																				
95	MORIMARIE B HASINA DALWISH		725,000	2016-016339																				
96	096-063-021-4		195,000	2010-06712																				
97	LOVE A CHILD MISSIONS		195,000	2016-0166351																				
98	LOVE A CHILD MISSIONS		195,000	2010-06713																				
99	LOVE A CHILD MISSIONS		195,000	2016-0166352																				
100	031-091-012-0		43,700	2010-06901																				
101	MARRINA VENTURES 64 LLC		10,700	2016-0166353																				
102	031-091-012-0		10,700	2010-06902																				
103	MARRINA VENTURES 64 LLC		8,200	2016-0166354																				
104	032-100-042-2		30,100	2010-06979																				
105	FERRY BERKOWITZ		56,200	2016-0166355																				
106	026-050-012-9		108,600	2010-06980																				
107	SOSONOWSKI & ASSOCIATES INC			2016-0166356																				
108	423-020-007-4			2010-06970																				
109	SKYE ALICE McLAUGHLIN			2016-0166357																				
110	426-040-072-8			2010-07129																				
111	MYNIT HAN			2016-0166358																				
112	426-040-073-6			2010-07130																				
113	MYNIT HAN			2016-0166359																				
114	426-040-074-4			2010-07131																				
115	MYNIT HAN			2016-0166360																				
116	426-040-075-1			2010-07132																				
117	MYNIT HAN			2016-0166361																				
118	426-040-076-9			2010-07133																				
119	MYNIT HAN			2016-0166362																				
120	409-261-009-8		14,200	2010-07364																				
121	FRED LINDENHART II			2016-0166363																				
122	419-123-024-4		48,200	2016-0166364																				
123	TK HIRAM INVESTMENT LLC			2016-0166365																				
124	419-123-024-4			2010-07392																				
125	TK HIRAM INVESTMENT LLC			2016-0166369																				
126	419-123-024-4			2010-07393																				
127	TK HIRAM INVESTMENT LLC			2016-0166370																				
128	419-123-026-9			2010-07394																				
129	TK HIRAM INVESTMENT LLC			2016-0166371																				
130	419-123-027-3			2010-07395																				
131	TK HIRAM INVESTMENT LLC			2016-0166372																				
132	419-123-028-5			2010-07396																				
133	TK HIRAM INVESTMENT LLC			2016-0166373																				
134	419-123-029-3			2010-07397																				
135	TK HIRAM INVESTMENT LLC			2016-0166374																				
136	419-123-030-7			2010-07398																				
137	TK HIRAM INVESTMENT LLC			2016-0166375																				
138	419-123-031-5			2010-07400																				
139	TK HIRAM INVESTMENT LLC			2016-0166376																				
140	419-123-032-8			2010-07401																				
141	TK HIRAM INVESTMENT LLC			2016-0166377																				
142	419-123-033-0			2010-07402																				
143	TK HIRAM INVESTMENT LLC			2016-0166378																				
144	419-123-034-1		16,400	2010-07403																				
145	TK HIRAM INVESTMENTS LLC			2016-0166379																				
146	419-142-020-9			2010-07405																				
147	TK HIRAM INVESTMENTS LLC			2016-0166380																				
148	419-142-021-7			2010-07406																				
149	TK HIRAM INVESTMENTS LLC			2016-0166381																				
150	419-142-022-5			2010-07407																				
151	TK HIRAM INVESTMENTS LLC			2016-0166382																				
152	419-142-023-3		8,200	2010-07408																				
153	TRICIA M MARISTELA			2016-0166383																				
154	419-142-024-1			2010-07409																				
155	TRICIA M MARISTELA			2016-0166384																				
156	419-142-025-8		53,300	2010-07410																				
157	TK HIRAM INVESTMENT LLC			2016-0166385																				
158	419-142-026-4			2010-07411																				
159	TK HIRAM INVESTMENT LLC			2016-0166386																				
160	419-142-027-4			2010-07412																				
161	TK HIRAM INVESTMENT LLC			2016-0166387																				
162	419-142-028-2			2010-07413																				
163	TK HIRAM INVESTMENT LLC			2016-0166388																				
164	419-142-029-8			2010-07414																				
165	TK HIRAM INVESTMENT LLC			2016-0166389																				
166	419-142-030-9			2010-07415																				
167	TK HIRAM INVESTMENT LLC			2016-0166390																				
168	419-142-031-5			2010-07416																				
169	TK HIRAM INVESTMENT LLC			2016-0																				





Contra  
Costa  
County

To: Board of Supervisors  
From: William Walker, M.D., Health Services Director  
Date: November 1, 2016

Subject: Approve New, Recredentialing and Organizational Providers in Contra Costa Health Plan's Community Provider Network

**RECOMMENDATION(S):**

Approve the list of providers recommended by the Contra Costa Health Plan's Medical Director on September 29, 2016 and by the Health Services Director, as required by the State Departments of Health Care Services and Managed Health Care, and the Centers for Medicare and Medicaid Services.

**FISCAL IMPACT:**

Not applicable.

**BACKGROUND:**

The National Committee on Quality Assurance (NCQA) requires that evidence of Board of Supervisors approval must be contained within each CCHP provider's credentials file. Approval of this list of providers as recommended by the CCHP Medical Director will enable the Contra Costa Health Plan to comply with this requirement.

**CONSEQUENCE OF NEGATIVE ACTION:**

If this action is not approved, Contra Costa Health Plan's Providers would not be appropriately credentialed and not be in compliance with the NCQA.

**CHILDREN'S IMPACT STATEMENT:**

Not applicable.

APPROVE

OTHER

RECOMMENDATION OF CNTY  
ADMINISTRATOR

RECOMMENDATION OF BOARD  
COMMITTEE

Action of Board On: **11/01/2016**  APPROVED AS  
RECOMMENDED

OTHER

Clerks Notes:

**VOTE OF SUPERVISORS**

AYE: John Gioia, District I Supervisor  
Candace Andersen, District II  
Supervisor  
Mary N. Piepho, District III Supervisor  
Karen Mitchoff, District IV Supervisor  
Federal D. Glover, District V Supervisor

I hereby certify that this is a true and correct copy of an action taken and entered on the minutes of the Board of Supervisors on the date shown.

ATTESTED: November 1, 2016

David J. Twa, County Administrator and Clerk of the Board of Supervisors

Contact: Patricia Tanquary,  
925-313-6004

By: June McHuen, Deputy

cc: Tasha Scott, Marcy Wilhelm, Heather Wong



ATTACHMENTS

Provider List

**Contra Costa Health Plan  
Providers Approved by Medical Director  
September 29, 2016**

<b>CREDENTIALING PROVIDERS SEPTEMBER 2016</b>	
<b>Name</b>	<b>Specialty</b>
Beers, Sonia, MFT	Mental Health Services
Chen, Eric, M.D.	Diagnostic Radiology
Dao, Dominique, BCBA	Behavior Analysis
Hamiel, Genoa, MFT	Mental Health Services
Jamali, Amir, M.D.	Orthopaedic Sports Medicine
James, Rosilda, PsyD	Mental Health Services
Kim, Euna, NP	Mid-Level Orthopaedic Surgery Assistant
King, Mariam, PsyD	Mental Health Services
Le, Jesse, M.D.	Urology
Merkow, Maxwell, M.D.	Surgery – Neurosurgical
Murphy, John, M.D.	Primary Care Internal Medicine/Pediatrics
Nam, Enoch, M.D.	Ophthalmology
Narasimhan, Shobha, DDS	Dentist
Sherman, Alexandra, NP	Mid-Level Gynecological Oncology
Smith, Tracy, PsyD	Mental Health Services
Tyler, Megan, NP	Primary Care Family Medicine
Veza, Valerie, LCSW	Mental Health Services
Winkler, Sarah, RBT	Behavior Analysis

<b>CREDENTIALING ORGANIZATIONAL PROVIDERS SEPTEMBER 2016</b>		
<b>Provider Name</b>	<b>Provide the Following Services</b>	<b>Location</b>
California Eye Clinic	Surgery Center	Antioch
Positive & Vigilant Healthcare, Inc. dba: Alhambra Convalescent Hospital	Skilled Nursing Facility	Martinez
Vibra Hospital of Sacramento, LLC dba: Vibra Hospital of Sacramento	Long Term Acute Care Hospital	Folsom

<b>RECREREDENTIALING PROVIDERS SEPTEMBER 2016</b>	
<b>Name</b>	<b>Specialty</b>
Dosanjh, Amarjit, M.D.	Surgery – Plastic
Hill, Anne B., NP	Mid-Level Family Planning
Junnila, Ricky, DC	Chiropractic Medicine
Kolomey, Irina, DO	Primary Care Internal Medicine
Kishiyama, Jessica, BCBA	Behavior Analysis
Kopiko, Karen, O.D.	Optometry
Krier, Margaret, MFT	Mental Health Services
Lee, Yen-Chung, M.D.	Surgery – Bariatric
Lo, Stephen, M.D.	Anesthesiology
Nyamora, Cory, PsyD	Mental Health Services
Pecci, Matthew, M.D	Sports Medicine
Pound, Michael, DC	Chiropractic Medicine
Rudnick, Craig, M.D.	Psychiatry
Shain, Philip, M.D.	Psychiatry/ Child & Adolescent Psychiatry
Stevenson, Mark, DDS	Endodontics

<b>RECREREDENTIALING ORGANIZATIONAL PROVIDERS SEPTEMBER 2016</b>		
<b>Provider Name</b>	<b>Provide the Following Services</b>	<b>Location</b>
Manor Care-Tice Valley CA, LLC dba: ManorCare Health Services- Tice Valley #381	Skilled Nursing Facility	Walnut Creek
Shields Nursing Centers, Inc. dba: Shields Nursing Center	Skilled Nursing Facility	El Cerrito
Shields Nursing Centers, Inc. dba: Shields/Richmond Nursing Center	Skilled Nursing Facility	Richmond
Windsor Rosewood Care Center, LLC dba: Windsor Rosewood Care Center	Skilled Nursing Facility	Pleasant Hill



Contra  
Costa  
County

To: Board of Supervisors  
From: William Walker, M.D., Health Services Director  
Date: November 1, 2016

Subject: Amendment #26-576-7 with Carrington College

---

**RECOMMENDATION(S):**

Approve and authorize the Health Services Director, or his designee, to execute, on behalf of the County, Contract Amendment Agreement #26-576-7 with Carrington College, an educational institution, effective October 1, 2016, to amend contract #26-576-3 (as amended by Agreement Agreements #26-576-4 through #26-576-6) to modify the Program Plan, to add a medical laboratory assistant classification, with no change in the original term of July 1, 2012 through June 30, 2020.

**FISCAL IMPACT:**

None.

**BACKGROUND:**

On October 16, 2012, the Board of Supervisors approved Contract #26-576-3 (as amended by Amendment Agreements #26-576-4 through #26-576-6) with Carrington College for the provision of providing supervised field instruction experience to provide various health care disciplines with Contra Costa Health Services, for the period from July 1, 2012 through June 30, 2020. Approval of Contract Amendment Agreement #26-576-7 will modify the Program Plan to add a medical laboratory assistant classification to receive field instruction at Contra Costa Regional Medical Center and Contra Costa Health Centers, through June 30, 2020.

APPROVE

OTHER

RECOMMENDATION OF CNTY  
ADMINISTRATOR

RECOMMENDATION OF BOARD  
COMMITTEE

---

Action of Board On: **11/01/2016**

APPROVED AS  
RECOMMENDED

OTHER

Clerks Notes:

**VOTE OF SUPERVISORS**

AYE: John Gioia, District I Supervisor  
Candace Andersen, District II Supervisor  
Mary N. Piepho, District III Supervisor  
Karen Mitchoff, District IV Supervisor  
Federal D. Glover, District V Supervisor

I hereby certify that this is a true and correct copy of an action taken and entered on the minutes of the Board of Supervisors on the date shown.

ATTESTED: November 1, 2016

David J. Twa, County Administrator and Clerk of the Board of Supervisors

By: June McHuen, Deputy

Contact: ANNA ROTH,  
925-370-5101

CONSEQUENCE OF NEGATIVE ACTION:

If this amendment is not approved, Contractor's students will not receive medical laboratory assistant supervised fieldwork instruction experience at Contra Costa Regional Medical Center and Contra Costa Health Centers.

CHILDREN'S IMPACT STATEMENT:

Not applicable.



Contra  
Costa  
County

To: Board of Supervisors  
From: Kathy Gallagher, Employment & Human Services Director  
Date: November 1, 2016

Subject: Community Financial Resources, Inc. Memorandum of Understanding

---

**RECOMMENDATION(S):**

APPROVE and AUTHORIZE the Employment and Human Services Director, or designee, to execute a memorandum of understanding containing mutual indemnification language, with Community Financial Resources, Inc. for a financial literacy and money management project for the period of September 1, 2016 through February 15, 2017.

**FISCAL IMPACT:**

One hundred percent of the stipend given to families will be funded through Community Financial Resources (CFR). The oversight, monitoring, and instruction to the financial literacy program participants will be integrated into the existing services provided by Community Services Bureau’s staff.

No additional county, state, and federal dollars will be utilized to provide these services.

**BACKGROUND:**

Community Financial Resources (CFR) and the Employment and Human Services, Community Services Bureau (CSB) will partner to provide a financial literacy program to parents

- 
- APPROVE  OTHER
  - RECOMMENDATION OF CNTY ADMINISTRATOR  RECOMMENDATION OF BOARD COMMITTEE
- 

Action of Board On: **11/01/2016**  APPROVED AS RECOMMENDED  OTHER

Clerks Notes:

**VOTE OF SUPERVISORS**

- AYE: John Gioia, District I Supervisor
- Candace Andersen, District II Supervisor
- Mary N. Piepho, District III Supervisor
- Karen Mitchoff, District IV Supervisor
- Federal D. Glover, District V Supervisor

I hereby certify that this is a true and correct copy of an action taken and entered on the minutes of the Board of Supervisors on the date shown.

ATTESTED: November 1, 2016  
David J. Twa, County Administrator and Clerk of the Board of Supervisors

By: June McHuen, Deputy

Contact: CSB (925) 681-6338

BACKGROUND: (CONT'D)

enrolled in CSB childcare programs. Bureau staff will provide oversight, monitoring, instruction to the program participants. CFR will provide the monetary incentives such as matching funds for savings accounts. The goal of the program is to strengthen the financial knowledge and capabilities of participants; connect participants with appropriate entry-level financial products and services including bank accounts; help develop more effective money management techniques and credit building habits for participants.

CONSEQUENCE OF NEGATIVE ACTION:

Community Services Bureau participants could not use the financial literacy and financial products to be provided through this agreement.

CHILDREN'S IMPACT STATEMENT:

None

ATTACHMENTS

CFR MOU

## Memorandum of Understanding

---

**Parties:** Contra Costa County (County) and Community Financial Resources (Agency)

**Background:** Community Financial Resources (CFR), a non-profit agency, and Contra Costa County, by and through its Employment and Human Services Department (EHSD), Community Services Bureau (CSB), wish to implement the Family Financial Fitness Program (Program) for parents receiving services from CSB. The Program is designed to incent beneficial money management behaviors, including appropriate financial product usage, and will be delivered by CSB, after training from CFR, to CSB parents through group workshops, events, 1-to-1 coaching, or a combination of all.

**Funding Source:** Annie E. Casey Foundation's Economic Security program grant. CFR is a grant recipient.

CFR and CSB will work jointly to implement the Program to:

1. Strengthen the financial knowledge and capabilities of CSB parents through behavior based incentives.
2. Help CSB parents develop money management techniques, savings habits, establish or improve credit scores/histories, and recognize credit as an asset.
3. Connect CSB parents with appropriate entry-level financial products and services, including accounts at banks, credit unions, and other CFR-sponsored/vetted products.
4. Build the capacity of CSB staff to deliver task-based financial education that promotes beneficial financial behaviors among participants.
5. Evaluate the impact of the consumer education and financial product usage on the households participating in the program.

**Term of Agreement:** September 1, 2016 – February 15, 2017. The incentive awards outlined in this MOU expires January 31, 2017 (unless extended or renewed). Reporting data for the Pilot must be submitted to the respective parties by February 15, 2017.

**Agency's Obligations** – CFR shall:

1. Provide a budget up to \$2,860.00 for client incentives over the full term of this MOU. Cash awards will be deposited onto CFR prepaid debit card accounts established by the parent (alternatives to be provided for parents without social security numbers). The following incentives will be offered:
  - a. Up to \$500 for workshop attendance incentives which can be food, amenities, or gift cards.
  - b. Up to \$750 for a total of six (6) \$125 cash prize drawings to award financial management behaviors documented on the Ticket Tracking Spreadsheet (Attachment A).



- i. Beneficial money management behaviors to be awarded must be approved by CFR.
    - ii. Ticket award weights to emphasize the more impactful behaviors, e.g. 1 ticket for X vs 2 tickets for Y vs 3 tickets for Z, must be approved by CFR.
  - c. One \$125 prize drawing for parents submitting post-program financial practices surveys by January 31, 2017. A minimum of thirty (30) post-program financial practices surveys must be returned for the drawing to take place.
  - d. Up to \$735 to fund the first seven (7) parents with \$105 Mini-Matches to open up a Cooperative Center Federal Credit Union (CCFCU) secured credit-builder card.
  - e. Up to \$750 to fund the first fifteen (15) parents with \$50 bonuses to open and fund CFR Focus Card Savings Account, establish a savings goal, and use an automatic savings trigger for at least three (3) months.
2. Assign a CFR manager to assist CSB in the implementation and support of the Program.
3. Work with CSB to shape the Program for their target audience.
4. Train CSB staff on the Program curriculum, concepts and approach including client activities that reinforce beneficial money management behaviors.
5. Work with CSB to develop appropriate Program marketing and outreach materials.
6. Provide information on CFR sponsored/vetted consumer friendly products, e.g. prepaid debit and secured credit cards, local credit union or community bank accounts, and train CSB staff on effectively integrating these products into the Program to reinforce money management concepts and beneficial behaviors.
7. Meet periodically with CSB to review project implementation and strategize improving program participation and effectiveness.
8. Coordinate the provision of attendance incentives.
9. Provide CSB any utilization data that may be available on CFR-sponsored products.
10. Share evaluation data with CSB to support the documentation of outcomes.
11. Comply with confidentiality requirements as specified in Head Start Performance Standards regulation 45 CFR 1304.41(a)(1).

## 12. Mutual Indemnification

- A. CFR shall defend, indemnify and hold harmless County, its officers, employees and agents, from and against any and all liability, loss, expense, or claims for injury or damages arising out of the performance of this Agreement but only in proportion to and to the extent such liability, loss, expense, or claims for injury or damages are caused by or result from the negligent or intentional acts or omissions of CFR, its officers, agents, or employees.

- B. County shall defend, indemnify and hold harmless CFR, its officers, employees and agents, from and against any and all liability, loss, expense, or claims for injury or damages arising out of the performance of this Agreement but only in proportion to and to the extent such liability, loss, expense, or claims for injury or damages are caused by or result from the negligent or intentional acts or omissions of County, its officers, agents, or employees.

13. All information collected from participants in the Program will be provided anonymously. CFR agrees that it will not disclose the identities of Program participants to third parties.

**County's Obligations** – CSB shall:

1. Assign one staff person to coordinate the Program and act as primary point of contact for CFR, who will meet monthly with CFR liaison to review program status.
2. Enroll parents in the Program by having them sign-in and complete an enrollment form at the workshops (Attachment B).
3. Document a Program delivery schedule for financial capability coursework, workshops or coaching sessions that will include a goal of working with at least seventy-five (75) unique parents as active participants.
4. Identify and train up to thirty-five (35) CSB staff members to deliver Program components for up to 75 parents enrolled in CSB programs. Publicize the availability of the Program to CSB parents.
5. Engage at least fifty (50) unique parents in beneficial money management behavior tracking system.
6. Help at least forty (40) parents open, fund, and use a bank or credit union account, CFR sponsored prepaid credit card, or secured credit card account through the use of CFR provided consumer education materials.
7. Assess thirty (30) parents' financial service needs through a baseline financial practices survey provided by CFR.
8. Conduct prize drawings. In order for a prize drawing to take place, at least thirty (30) tickets must be in the pool.
  - a. A ticket can be in one (1) pool only.
  - b. After the prize drawing takes place, all tickets making up that pool must be discarded.
9. Document beneficial behaviors and ticket awards for at least fifty (50) parents participating in the prize drawing and submit electronic versions of CFR's Ticket Tracker spreadsheet to indicate the number of tickets given.
  - a. Include comments, as appropriate, e.g. set-up and usage of bank or credit union accounts.

10. Compare credit scores for all parents who voluntarily get and qualify for the CCFCU secured credit-builder card. The credit score will be tracked at time of credit application and credit score at the end of the program (can be Credit Karma Vintage Score). The parent's credit score will go on the Savings Match Agreement authorizing CFR to monitor the change in credit score over time. That form is scanned and emailed to CFR to be stored on a secure server.
11. Collect post-program financial practices surveys from a goal of at least thirty (30) parents.
12. Follow the CFR's procedures outlined in Part I.1(d) to claim the product incentive award.
13. Retain the records identified in items nine (9) through eleven (11) for three (3) years from the expiration of the terms of agreement.
14. Destroy documents identified in items nine (9) through eleven (11) when its retention period has expired.
15. Cite CFR's authorship of Program materials appropriately and only use CFR provided materials with CFR's prior permission.
16. Provide feedback to CFR on its performance.

The signatures below have the authority to commit their respective organizations to the terms and conditions of this Memorandum of Understanding.

For Community Financial Resources:

---

Lauren Leimbach, Executive Director  
Lauren@communityfinancialresources.net

---

Date

For Contra Costa County Employment & Human Services Department

---

Kathy Gallagher, Executive Director  
KGallagher@ehsd.cccounty.us

---

Date



Contra  
Costa  
County

To: Board of Supervisors  
From: David Twa, County Administrator  
Date: November 1, 2016

Subject: 2017 MEETING SCHEDULE FOR THE CONTRA COSTA COUNTY BOARD OF SUPERVISORS

---

**RECOMMENDATION(S):**

ADOPT the attached 2017 meeting schedule for the Contra Costa County Board of Supervisors, including the cancelation of those meetings at which it is anticipated there will not be a quorum of Board members present, as well as noting the following scheduled special events: a special meeting to receive a presentation on the County's economic forecast, on on January 9; the Board's Annual Reorganization on January 10; the Dr. Martin Luther King, Jr. Celebration on January 17; the annual Board retreat on January 31; the Cesar Chavez Commemorative Celebration on March 28; Annual Budget Hearings and Adoption on April 18 and May 9, respectively; and the Veterans Day Recognition on November 7.

**FISCAL IMPACT:**

None.

**BACKGROUND:**

Each year, the Board of Supervisors adopts a meeting schedule that designates regular meeting dates and any dates on which meetings must be canceled in anticipation that a quorum of the Board will not be present. The 2017 meeting schedule, as modified by the Board of Supervisors on October 25, 2016, was prepared in consultation with the incoming Board Chair, Fire Chief and the Housing Authority Executive Director. The schedule provides 34 meetings for the Contra Costa County Board of Supervisors and 12 meetings for each the Contra Costa County Fire Protection District Board of Directors and the Housing Authority of Contra Costa Board of Commissioners. The Fire District and Housing Authority will take independent action on December 6 to adopt their meeting schedules.

APPROVE

OTHER

RECOMMENDATION OF CNTY  
ADMINISTRATOR

RECOMMENDATION OF BOARD  
COMMITTEE

Action of Board On: **11/01/2016**  APPROVED AS  
RECOMMENDED

OTHER

Clerks Notes:

**VOTE OF SUPERVISORS**

AYE: John Gioia, District I Supervisor  
Candace Andersen, District II  
Supervisor  
Mary N. Piepho, District III Supervisor  
Karen Mitchoff, District IV Supervisor  
Federal D. Glover, District V Supervisor

I hereby certify that this is a true and correct copy of an action taken and entered on the minutes of the Board of Supervisors on the date shown.

ATTESTED: November 1, 2016

David J. Twa, County Administrator and Clerk of the Board of Supervisors

Contact: Julie DiMaggio Enea  
925.335.1077

By: June McHuen, Deputy

cc:

**BACKGROUND: (CONT'D)**

>

As in past years, we are recommending that the Board cancel those meetings that fall during a week with a County holiday, the fifth Tuesday of a month, and Tuesdays that fall during those weeks in which the annual policy and legislative meetings of the National Association of Counties (NACo) and the California State of Counties (CSAC) are held:

<b><u>Conference</u></b>	<b><u>Dates</u></b>	<b><u>Location</u></b>
NACo Legislative Conference	February 25-March 1, 2017	Washington, D.C.
CSAC Legislative Conference	May 17-18, 2017	Sacramento, CA
NACo Annual Conference & Exposition	July 21-24, 2017	Columbus, OH
CSAC Annual Meeting	November 27-December 1, 2017	Sacramento, CA

In the past 10 years, several seasonal breaks have also been designated in the Board's meeting schedule, in recognition of both time away needed for vacations and of the time demands on the Board members due to their participation on Board standing committees, and numerous regional and local legislative bodies and task forces, which require preparation, attendance, and involve travel. We are recommending eight seasonal breaks to accommodate these needs. Experience has shown that 32 meetings per year has generally been sufficient to effectively conduct the County's business. However, should it be necessary, there are legal provisions to schedule a special meeting to address any urgent need that cannot be accommodated in the standing meeting schedule.

**CONSEQUENCE OF NEGATIVE ACTION:**

Early adoption of a meeting schedule enables staff to effectively plan and manage the Board's calendar and obtain the necessary authority to conduct the County's daily business. To the extent that the Board does not adopt a new year meeting schedule, staff will be hindered in these efforts.

**ATTACHMENTS**

2017 Board of Supervisors Meeting Schedule

**CONTRA COSTA COUNTY BOARD OF SUPERVISORS  
2017 MEETING SCHEDULE**

MEETING DATES (Tuesdays)	MEET OR CANCEL	HOUSING AUTHORITY/ CCCFPD	SPECIAL EVENT/COMMENT
Jan 03	Cancel		New Year's Day Holiday
<b>** Jan 09</b>	Meet		Special Meeting: Economic Forecast
<b>** Jan 10</b>	Meet		Reorganization Meeting
<b>** Jan 17</b>	Meet	HA/FIRE	Dr. Martin Luther King, Jr. Celebration
Jan 24	Cancel		
<b>** Jan 31</b>	Meet		Board Retreat
Feb 07	Meet		
Feb 14	Meet	HA/FIRE	
Feb 21	Cancel		President's Day
Feb 28	Cancel		NACo Leg Conference, Feb 25 - Mar 1, Washington, D.C.
Mar 07	Meet		Service Awards
Mar 14	Meet	HA/FIRE	
Mar 21	Meet		
<b>** Mar 28</b>	Meet		Cesar Chavez Celebration
Apr 04	Cancel		SPRING BREAK
Apr 11	Cancel		SPRING BREAK
<b>** Apr 18</b>	Meet	HA/FIRE	Budget Hearings
Apr 25	Meet		
May 02	Meet		
<b>** May 09</b>	Meet	HA/FIRE	Budget Adoption
May 16	Cancel		CSAC Leg Conf, May 17-18, 2017, Sacramento
May 23	Meet		
May 30	Cancel		Memorial Day/Fifth Tuesday
* Jun 06	Meet		
Jun 13	Meet	HA/FIRE	
Jun 20	Meet		Service Awards
Jun 27	Cancel		SUMMER BREAK
Jul 04	Cancel		Independence Day Holiday
* Jul 11	Meet	HA/FIRE	
Jul 18	Meet		
Jul 25	Cancel		NACo Annual Conf, July 21-24, Columbus, OH
Aug 01	Meet		
Aug 08	Meet	HA/FIRE	
Aug 15	Meet		
Aug 22	Cancel		SUMMER BREAK
Aug 29	Cancel		Fifth Tuesday
Sep 05	Cancel		Labor Day Holiday
* Sep 12	Meet	HA/FIRE	
Sep 19	Meet		
Sep 26	Meet		Service Awards
Oct 03	Cancel		FALL BREAK
Oct 10	Meet		
Oct 17	Meet	HA/FIRE	
Oct 24	Meet		
Oct 31	Cancel		Fifth Tuesday
<b>** Nov 07</b>	Meet		Veterans Day Recognition
Nov 14	Meet	HA/FIRE	
Nov 21	Cancel		Thanksgiving Holiday
Nov 28	Cancel		CSAC Annual Meeting, Nov 27-Dec 1, Sacramento County
* Dec 05	Meet		
Dec 12	Meet	HA/FIRE	
Dec 19	Meet		
Dec 26	Cancel		Christmas

\* Note: Emboldened dates vary from the normal 12-day schedule.

**\*\*Special BOS Celebration or Hearing**



Contra  
Costa  
County

To: Board of Supervisors  
From: David Twa, County Administrator  
Date: November 1, 2016

Subject: Brentwood Union School District General Obligation Bonds, Election of 2016, Series 2016

---

**RECOMMENDATION(S):**

ADOPT Resolution No. 2016/630 authorizing the issuance and sale of "Brentwood Union School District General Obligation Bonds, Election of 2016, Series 2016" in an amount not to exceed \$25,000,000 by the Brentwood Union School District on its own behalf pursuant to Section 15140(b) of the Education Code.

**FISCAL IMPACT:**

There is no fiscal impact to the County.

**BACKGROUND:**

The Brentwood Union School District intends to issue General Obligation bonds to fund capital improvements throughout the District. The District has requested that the Board of Supervisors adopt a resolution authorizing the direct issuance and sale of bonds by the District on its own behalf as authorized by Section 15140(b) of the Education Code.

The District adopted a resolution on October 26, 2016 authorizing the sale and issuance of the bonds (copy attached). This issuance was approved by the voters as part of a \$158,000,000 bond measure listed on the June 7, 2016 ballot.

**CONSEQUENCE OF NEGATIVE ACTION:**

Without the Contra Costa County Board of Supervisors authorization, the School District would not be able to issue the bonds as proposed.

APPROVE

OTHER

RECOMMENDATION OF CNTY  
ADMINISTRATOR

RECOMMENDATION OF BOARD  
COMMITTEE

---

Action of Board On: **11/01/2016**

APPROVED AS  
RECOMMENDED

OTHER

Clerks Notes:

**VOTE OF SUPERVISORS**

AYE: John Gioia, District I Supervisor  
Candace Andersen, District II Supervisor  
Mary N. Piepho, District III Supervisor  
Karen Mitchoff, District IV Supervisor  
Federal D. Glover, District V Supervisor

I hereby certify that this is a true and correct copy of an action taken and entered on the minutes of the Board of Supervisors on the date shown.

ATTESTED: November 1, 2016

David J. Twa, County Administrator and Clerk of the Board of Supervisors

By: Stephanie Mello, Deputy

Contact: Timothy Ewell,  
925-335-1036

cc:

CHILDREN'S IMPACT STATEMENT:

The recommendation supports the following Children's Report Card outcome: Communities that are Safe and Provide a High Quality of Life for Children and Families.

ATTACHMENTS

Resolution No. 2016/630

District Resolution



**THE BOARD OF SUPERVISORS OF CONTRA COSTA COUNTY, CALIFORNIA**  
**and for Special Districts, Agencies and Authorities Governed by the Board**

Adopted this Resolution on 11/01/2016 by the following vote:

		<b>John Gioia</b>
		<b>Candace Andersen</b>
<b>AYE:</b>	<input checked="" type="checkbox"/>	<b>Mary N. Piepho</b>
		<b>Karen Mitchoff</b>
		<b>Federal D. Glover</b>
<b>NO:</b>	<input type="checkbox"/>	
<b>ABSENT:</b>	<input type="checkbox"/>	
<b>ABSTAIN:</b>	<input type="checkbox"/>	
<b>RECUSE:</b>	<input type="checkbox"/>	



**Resolution No. 2016/630**

**RESOLUTION AUTHORIZING THE BRENTWOOD UNION SCHOOL DISTRICT TO ISSUE ITS BRENTWOOD UNION SCHOOL DISTRICT (CONTRA COSTA COUNTY, CALIFORNIA), GENERAL OBLIGATION BONDS, ELECTION OF 2016, SERIES 2016 IN AN AGGREGATE PRINCIPAL AMOUNT NOT TO EXCEED \$25,000,000 WITHOUT FURTHER ACTION OF THE BOARD OF SUPERVISORS OR OFFICERS OF THE COUNTY**

**RESOLVED**, by the Board of Supervisors of the County of Contra Costa, State of California, that:

**WHEREAS**, an election was duly and regularly held in the Brentwood Union School District (the "District") on June 7, 2016, in accordance with Section 1(b)(3) of Article XIII A of the California Constitution, for the purpose of submitting a bond measure to the qualified electors of the District, authorizing the issuance of general obligation bonds in the aggregate principal amount of \$158,000,000 (the "Bonds"), and more than 55% of the votes cast were in favor of the issuance of the Bonds; and

**WHEREAS**, Sections 53506 and following of the California Government Code (the "Government Code"), including Section 53508.7 thereof, provide that a school district may issue and sell bonds on its own behalf at a private sale pursuant to Section 15140 and 15146 of the California Education Code (the "Education Code"); and

**WHEREAS**, Section 15140(b) of the Education Code provides that the board of supervisors of a county may authorize a school district over which the county superintendent of schools has jurisdiction, and which has not received a qualified or negative certification in its most recent interim report, to issue and sell bonds on its own behalf without further action of the board of supervisors or officers of the county; and

**WHEREAS**, the Board of Education of the District, a school district under the jurisdiction of the Superintendent of Schools of the County of Contra Costa, adopted on October 26, 2016, a resolution (the "District Resolution") providing for the issuance of its "Brentwood Union School District (Contra Costa County, California), General Obligation Bonds, Election of 2016, Series 2016," in an aggregate initial principal amount not to exceed \$25,000,000, in one or more series to be designated by the District (the "Series 2016 Bonds") pursuant to Section 53506 and following of the Government Code and additionally providing for the negotiated sale thereof pursuant to Sections 15140 and 15146 of the Education Code; and

**WHEREAS**, by said District Resolution, the District has requested that this Board of Supervisors (the "Board") of the County of Contra Costa (the "County") authorize the District on its own behalf to issue and sell the Series 2016 Bonds at a negotiated sale, all pursuant to Sections 53506 and following of the Government Code and Section 15140(b) of the Education Code and subject to the terms set forth in the District Resolution, and has represented and warranted to the Board that it has not received a qualified or negative certification in its most recent interim report;

**NOW THEREFORE, IT IS HEREBY DETERMINED AND ORDERED** as follows:

**Section 1. Recitals.** All of the above recitals are true and correct.

**Section 2. Authorization of District Issuance and Sale.** The Board hereby authorizes the issuance and private negotiated sale of the Series 2016 Bonds by the District on its own behalf, pursuant to the terms set forth in the District Resolution and as

authorized by and in full compliance with all applicable laws, including but not limited to Sections 15140 and 15146 of the Education Code, as permitted by Section 53508.7 of the Government Code, as determined by the District's bond counsel. This authorization shall only apply to the Series 2016 Bonds authorized to be issued by said District Resolution.

**Section 3. Purpose.** The purpose of this action is to permit the District to sell its Series 2016 Bonds in the manner that the District determines is in its best interests and the best interests of its taxpayers, as provided in the District Resolution.

**Section 4. District Responsibilities.** Pursuant to Section 15140(c) of the Education Code, the Board of Education of the District shall transmit the District Resolution and a copy of the final debt service schedule for the Series 2016 Bonds, reflecting the principal amounts and interest rates of such Series 2016 Bonds as determined in the sale thereof, to the Treasurer-Tax Collector of the County (the "County Treasurer") and to the County Controller (the "County Controller"), forthwith after the sale of the Series 2016 Bonds, and in any event no later than the date reasonably requested by such officers, in order to permit the County to establish tax rates and necessary funds or accounts for the Series 2016 Bonds.

**Section 5. County Responsibilities.** (a) The County, including the officers thereof and this Board of Supervisors, assumes no responsibility for any of the proceedings following the adoption of this Resolution which involve or result in the sale and issuance of the Series 2016 Bonds, including but not limited to, any proceedings for the sale and issuance of the Series 2016 Bonds or the validity of the Series 2016 Bonds. (b) The County shall levy and collect taxes, pay principal and interest on the Series 2016 Bonds when due, and hold the bond proceeds and tax funds for the Series 2016 Bonds that have been duly issued and sold by the District as otherwise required by law. (c) The County, including the officers and employees thereof and this Board of Supervisors, assumes no responsibility for establishing a tax rate for any new issue of bonds in any year in which the information required by Section 4 hereof to be delivered to the County officers is delivered later than the deadline established by such officers in order to permit compliance with Government Code Section 29100 and following. (d) Except as otherwise provided by this Resolution and by law, neither the County, this Board or any officers, officials or employees of the County shall have any liability hereunder or by reason hereof or in connection with the transactions contemplated hereby and the Series 2016 Bonds shall be payable solely from tax proceeds available therefor as set forth in this Section 5.

**Section 6. Delegation to County Treasurer.** The County Treasurer, or his/her designee, is hereby authorized and directed to act on behalf of and with the authority of the County to take any official action and to execute and deliver any certificates, receipts, orders, or other documents required or intended to be signed and delivered by the County, which the County Treasurer deems necessary or advisable, in connection with the issuance and delivery of the Series 2016 Bonds.

**Section 7. Indemnification of County.** The County acknowledges and relies upon the fact that the District has represented that it shall indemnify and hold harmless, to the extent permitted by law, the County and its officers and employees ("Indemnified Parties"), against any and all losses, claims, damages or liabilities, joint or several, to which such Indemnified Parties may become subject because of action or inaction related to the adoption of this Resolution, or related to the proceedings for sale, award, issuance and delivery of the Series 2016 Bonds in accordance herewith and with the District Resolution and that the District shall also reimburse any such Indemnified Parties for any legal or other expenses incurred in connection with investigating or defending any such claims or actions.

**Section 8. Limited Responsibility for Official Statement.** Neither this Board of Supervisors nor any officer of the County has prepared or reviewed the official statement of the District describing the Series 2016 Bonds (the "Official Statement"), and this Board of Supervisors and the various officers of the County take no responsibility for the contents or distribution thereof; provided, however, that solely with respect to a section contained or to be contained therein describing the County's investment policy, current portfolio holdings and valuation procedures, as they may relate to funds of the District held by the County Treasurer, the County Treasurer is hereby authorized and directed to prepare and review such information for inclusion in the District's Official Statement and in a preliminary Official Statement, and to certify in writing prior to or upon the issuance of the Series 2016 Bonds that the information contained in such section does not contain any untrue statement of a material fact or omit to state any material fact necessary in order to make the statements made therein, in the light of the circumstances under which they are made, not misleading.

**Section 9. Delivery of Resolution.** The Clerk of the Board of Supervisors is hereby directed to deliver a copy of this Resolution to the Superintendent of the District.

**Section 10. Effective Date:** This Resolution shall take effect from and after its adoption.

I hereby certify that this is a true and correct copy of an action taken and entered on the minutes of the Board of Supervisors on the date shown.

**ATTESTED: November 1, 2016**

David J. Twa, County Administrator and Clerk of the Board of Supervisors

Contact: Timothy Ewell, 925-335-1036

By: Stephanie Mello, Deputy

**cc:**

**RESOLUTION NO. 2016-21**

**RESOLUTION OF THE BOARD OF EDUCATION OF THE BRENTWOOD UNION SCHOOL DISTRICT AUTHORIZING THE ISSUANCE AND SALE OF NOT TO EXCEED \$25,000,000 AGGREGATE PRINCIPAL AMOUNT OF BONDS OF BRENTWOOD UNION SCHOOL DISTRICT, BY A NEGOTIATED SALE PURSUANT TO A BOND PURCHASE AGREEMENT, PRESCRIBING THE TERMS OF SALE, APPROVING THE FORM OF AND AUTHORIZING THE EXECUTION AND DELIVERY OF A BOND PURCHASE AGREEMENT AND A CONTINUING DISCLOSURE CERTIFICATE, APPROVING THE FORM OF AND AUTHORIZING THE DISTRIBUTION OF AN OFFICIAL STATEMENT FOR THE BONDS, AND AUTHORIZING THE EXECUTION OF NECESSARY DOCUMENTS AND CERTIFICATES AND RELATED ACTIONS**

**WHEREAS**, an election was duly called and regularly held in the Brentwood Union School District, County of Contra Costa, California (the "District"), on June 7, 2016, at which the following proposition (as abbreviated pursuant to Section 13247 of the California Elections Code) was submitted to the electors of the District (the "Bond Measure"):

*"To provide Brentwood students with 21st century classrooms, upgrade libraries and science labs, improve school safety and security, expand access to classroom technology for students and teachers, renovate and modernize older schools in the District, build a new elementary school, and replace, acquire, construct and renovate school facilities, shall the Brentwood Union School District issue \$158,000,000 in bonds, at legal interest rates, with an independent citizens' oversight committee and no funds spent on administrators salaries?"*

**WHEREAS**, at least 55% of the votes cast on the proposition were in favor of issuing the bonds; and

**WHEREAS**, at this time, the Board of Education (the "Board of Education") of the District deems it necessary and desirable to authorize and consummate the sale of a portion of the bonds, designated the "Brentwood School District (Contra Costa County, California) General Obligation Bonds, Election of 2016, Series 2016" (the "Series 2016 Bonds"), with such additional or other series or subseries designations as may be approved as herein provided, in an aggregate principal amount not exceeding \$25,000,000, for purposes of financing projects authorized to be financed under the Bond Measure, according to the terms and in the manner hereinafter set forth; and

**WHEREAS**, Sections 53506 and following of the California Government Code (the "Government Code"), including Section 53508.7 thereof, provide that a school district may issue and sell bonds on its own behalf at a private or negotiated sale pursuant to Sections 15140 and 15146 of the California Education Code (the "Education Code"); and

**WHEREAS**, Section 15140(b) of the Education Code provides that the board of supervisors of a county may authorize a school district in the county to issue and sell its own bonds without the further action of the board of supervisors or officers of the county if said school district has not received a qualified or negative certification in its most recent interim report; and

**WHEREAS**, the District has not received a qualified or negative certification in its most recent interim report; and

**WHEREAS**, the Series 2016 Bonds shall be issued and sold by the District on its own behalf at a negotiated sale pursuant to authorization to be obtained from the Board of Supervisors (the "Board of Supervisors") of the County of Contra Costa (the "County"); and

**WHEREAS**, the Board of Education has determined that securing the timely payment of the principal of and interest on the Series 2016 Bonds by obtaining a municipal bond insurance policy with respect thereto could be economically advantageous to the District; and

**WHEREAS**, a form of Bond Purchase Agreement (such Bond Purchase Agreement, in the form presented to this meeting, with such changes, insertions and omissions as are made pursuant to this Resolution, being referred to herein as the "Bond Purchase Agreement") to purchase the Series 2016 Bonds proposed to be entered into with one or more underwriters selected by the District as herein provided pursuant a proposal process (collectively, the "Underwriter") has been prepared; and

**WHEREAS**, Rule 15c2-12 promulgated under the Securities Exchange Act of 1934 ("Rule 15c2-12") requires that, in order to be able to purchase or sell the Series 2016 Bonds, the Underwriter must have reasonably determined that the issuer or other obligated person has undertaken in a written agreement or contract for the benefit of the holders of the Series 2016 Bonds to provide disclosure of certain financial and operating information and certain enumerated events on an ongoing basis; and

**WHEREAS**, in order to cause such requirement to be satisfied, the District desires to execute and deliver a Continuing Disclosure Certificate (such Continuing Disclosure Certificate, in the form presented to this meeting, with such changes, insertions and omissions as are made pursuant to this Resolution, being referred to herein as the "Continuing Disclosure Certificate"), a form of which has been prepared; and

**WHEREAS**, the Preliminary Official Statement to be distributed in connection with the public offering of the Series 2016 Bonds has been prepared (such Preliminary Official Statement, in the form presented to this meeting, with such changes, insertions and omissions as are made pursuant to this Resolution, being referred to herein as the "Preliminary Official Statement"); and

**WHEREAS**, the Board of Education has been presented with the form of each document referred to herein relating to the financing contemplated hereby, and the Board of Education has examined each document and desires to approve, authorize and direct the execution of such documents and the consummation of such financing; and

**WHEREAS**, the District desires that the Auditor-Controller of the County annually establish tax rates on taxable property within the District for repayment of said bonds, pursuant to Sections 29100-29103 of the Government Code, that the Board of Supervisors of the County annually approve the levy of such tax, and that the Treasurer-Tax Collector of the County annually collect such tax and apply the proceeds thereof to the payment of principal of and interest on the Series 2016 Bonds when due, all pursuant to Sections 15250 and 15251 of the Education Code; and

**WHEREAS**, all acts, conditions and things required by the Constitution and laws of the State of California to exist, to have happened and to have been performed precedent to and in connection with the consummation of the actions authorized hereby do exist, have happened and have been performed in regular and due time, form and manner as required by law, and the District is now duly authorized and empowered, pursuant to each and every requirement of law, to consummate such actions for the purpose, in the manner and upon the terms herein provided;

**NOW, THEREFORE, BE IT RESOLVED** by the Board of Education of the Brentwood Union School District, as follows:

**Section 1. Recitals.** All of the above recitals are true and correct and the Board of Education so finds.

**Section 2. Definitions.** Unless the context clearly otherwise requires, the terms defined in this Section shall, for all purposes of this Resolution, have the meanings specified herein, to be equally applicable to both the singular and plural forms of any of the terms herein defined.

**“Auditor-Controller”** means the Auditor-Controller of the County or any authorized deputy thereof.

**“Authorized Officers”** means the President of the Board of Education, or such other member of the Board of Education as the President may designate, the Superintendent of the District, the Chief Business Official of the District, or such other officer or employee of the District as the Superintendent may designate.

**“Board of Education”** means the Board of Education of the District.

**“Board of Supervisors”** means the Board of Supervisors of the County.

**“Bond Purchase Agreement”** means the Bond Purchase Agreement relating to the sale of the Series 2016 Bonds by and between the District and the Underwriter in accordance with the provisions hereof.

**“Bonds”** means all bonds, including refunding bonds, of the District heretofore or hereafter issued pursuant to voter approved measures of the District, including bonds approved by the voters pursuant to the Bond Measure and Measure B (approved by the voters on March 4, 2003).

**“Cede & Co.”** means Cede & Co., the nominee of DTC, and any successor nominee of DTC with respect to the Series 2016 Bonds.

**“Code”** means the Internal Revenue Code of 1986.

**“Continuing Disclosure Certificate”** means the Continuing Disclosure Certificate executed and delivered by the District relating to the Series 2016 Bonds.

**“County”** means the County of Contra Costa.

**“District”** means the Brentwood Union School District.

**“DTC”** means The Depository Trust Company, a limited-purpose trust company organized under the laws of the State of New York, and its successors as securities depository for the Series 2016 Bonds, including any such successor thereto appointed pursuant to Section 9 hereof.

**“Interest Payment Date”** means February 1 and August 1 of each year, commencing on February 1, 2017, or such other dates as may be set forth in the Bond Purchase Agreement.

**“Official Statement”** means the Official Statement of the District relating to the Series 2016 Bonds.

**“Opinion of Bond Counsel”** means an opinion of counsel of nationally recognized standing in the field of law relating to municipal bonds.

**“Owner”** means, with respect to any Series 2016 Bond, the person whose name appears on the Registration Books as the registered Owner thereof.

**“Paying Agent”** means The Bank of New York Mellon Trust Company, N.A., or any bank, trust company, national banking association or other financial institution appointed as Paying Agent to act as authenticating agent, bond registrar, transfer agent and paying agent for the Series 2016 Bonds in accordance with Section 8 hereof.

**“Preliminary Official Statement”** means the Preliminary Official Statement of the District relating to the Series 2016 Bonds.

**“Record Date”** means, with respect to any Interest Payment Date for the Series 2016 Bonds, the 15th day of the calendar month immediately preceding such Interest Payment Date, whether or not such day is a business day, or such other date or dates as may be set forth in the Bond Purchase Agreement.

**“Registration Books”** means the books for the registration and transfer of the Series 2016 Bonds maintained by the Paying Agent in accordance with Section 8(d) hereof.

**“Series 2016 Bonds”** means the bonds authorized and issued pursuant to this Resolution, in one or more series or subseries, designated the “Brentwood Union School District (Contra Costa County, California) General Obligation Bonds, Election of 2016, Series 2016,” with such additional or other series or subseries designations as may be approved as herein provided.

**“State”** means the State of California.

**“Tax Certificate”** means the Tax Certificate with respect to the Series 2016 Bonds not issued as Taxable Bonds, executed by the District, dated the date of issuance of the Series 2016 Bonds.

**“Tax-Exempt”** means, with respect to interest on any obligations of a state or local government, that such interest is excluded from the gross income of the holders thereof for federal income tax purposes, whether or not such interest is includable as an item of tax preference or otherwise includable directly or indirectly for purposes of calculating other tax liabilities, including any alternative minimum tax or environmental tax under the Code.

**“Taxable Bonds”** means those Series 2016 Bonds the interest on which is not Tax-Exempt.

**“Treasurer”** means Treasurer-Tax Collector of the County or any authorized deputy thereof.

**“Underwriter”** has the meaning set forth in the recitals hereto.

**Section 3. Authorization and Designation of Bonds.** Subject to the authorization of the District by the Board of Supervisors of the County to issue and sell the Series 2016 Bonds without the further action of the Board of Supervisors pursuant to Sections 15140 and 15146 of the Education Code, as permitted by Section 53508.7 of the Government Code, which authorization is hereby respectfully requested, the Series 2016 Bonds described herein are being issued pursuant to the authority of Article 4.5 of Chapter 3, of Part 1 of Division 2 of Title 5 of the Government Code, and other applicable provisions of law, including applicable provisions of the Education Code. The Board of Education hereby authorizes the issuance and sale, by a negotiated sale, of not to exceed \$25,000,000 aggregate principal amount of Series 2016 Bonds. The Series 2016 Bonds may be issued in one or more series or subseries and shall be designated “Brentwood Union School District (Contra Costa County, California) General Obligation Bonds, Election of 2016, Series 2016,” with appropriate additional or other series or subseries designations as approved by an Authorized Officer. The proceeds of the Series 2016 Bonds, exclusive of any premium and accrued interest received, shall be applied to finance projects authorized to be financed under the Bond Measure.

**Section 4. Form of Bonds; Execution.** (a) *Form of Series 2016 Bonds.* The Series 2016 Bonds shall be issued in fully registered form without coupons. The Series 2016 Bonds and the certificate of authentication and registration and the form of assignment to appear on each of them, shall be in substantially the form attached hereto as Exhibit A, with necessary or appropriate variations, omissions and insertions as permitted or required by this Resolution.

(b) *Execution of Bonds.* The Series 2016 Bonds shall be signed by the manual or facsimile signatures of the President of the Board of Education, and countersigned by the manual or facsimile signature of the Clerk of the Board of Education. The Series 2016 Bonds shall be authenticated by a manual signature of a duly authorized signatory of the Paying Agent.

(c) *Valid Authentication.* Only such of the Series 2016 Bonds as shall bear thereon a certificate of authentication and registration as described in subsection (a) of this Section, executed by the Paying Agent, shall be valid or obligatory for any purpose or entitled to the



benefits of this Resolution, and such certificate of authentication and registration shall be conclusive evidence that the Series 2016 Bonds so authenticated have been duly authenticated and delivered hereunder and are entitled to the benefits of this Resolution.

(d) *Identifying Number.* The Paying Agent shall assign each Series 2016 Bond authenticated and registered by it a distinctive letter, or number, or letter and number, and shall maintain a record thereof at its principal office, which record shall be available to the District and the County for inspection.

**Section 5. Terms of Bonds.** (a) *Date of Series 2016 Bonds.* The Series 2016 Bonds shall be dated the date of their delivery, or such other date as shall be set forth in the Bond Purchase Agreement.

(b) *Denominations.* The Series 2016 Bonds shall be issued in denominations of \$5,000 principal amount or any integral multiple thereof.

(c) *Maturity.* The Series 2016 Bonds shall mature on the date or dates, in each of the years, in the principal amounts and in the aggregate principal amount as shall be set forth in the Bond Purchase Agreement. No Series 2016 Bond shall mature later than the date which is 30 years from the date of the Series 2016 Bonds, to be determined as provided in subsection (a) of this Section; provided, however, that Series 2016 Bonds may have a maturity greater than 30 years, but not greater than 40 years, if an Authorized Officer, for and on behalf of the District, makes a finding in writing that the useful life of the facility financed with such Series 2016 Bonds equals or exceeds the maturity date of such Series 2016 Bonds. No Series 2016 Bond shall have principal maturing on more than one principal maturity date.

(d) *Interest.* The Series 2016 Bonds shall bear interest at an interest rate or rates not to exceed 8.00% per annum, payable on the Interest Payment Dates in each year computed on the basis of a 360-day year of twelve 30-day months. Each Series 2016 Bond shall bear interest from the Interest Payment Date next preceding the date of authentication thereof, unless it is authenticated after the close of business on a Record Date and on or prior to the succeeding Interest Payment Date, in which event it shall bear interest from such Interest Payment Date, or unless it is authenticated on or before the Record Date preceding the first Interest Payment Date, in which event it shall bear interest from its dated date; provided, however, that if, at the time of authentication of any Series 2016 Bond, interest is in default on any outstanding Series 2016 Bonds, such Series 2016 Bond shall bear interest from the Interest Payment Date to which interest has previously been paid or made available for payment on the outstanding Series 2016 Bonds.

(e) *Interest; Tax-Exempt or Taxable.* Each series of Series 2016 Bonds may be issued such that the interest on such series of Series 2016 Bonds is Tax-Exempt or such that the interest on such series of Series 2016 Bonds is not Tax-Exempt. The Board of Education hereby finds and determines that, pursuant to Section 5903 of the California Government Code, the interest payable on each series of Series 2016 Bonds issued as Taxable Bonds will be subject to federal income taxation under the Code in existence on the date of issuance of such series of Series 2016 Bonds.

**Section 6. Payment of Bonds.** (a) *Request for Tax Levy.* The money for the payment of principal, redemption premium, if any, and interest on the Series 2016 Bonds shall be raised by taxation upon all taxable property in the District and provision shall be made for the levy and collection of such taxes in the manner provided by law and for such payment out of the interest and sinking fund of the District. The Board of Supervisors and officers of the County are obligated by statute to provide for the levy and collection of property taxes in each year sufficient to pay all principal and interest coming due on the Series 2016 Bonds in such year, and to pay from such taxes all amounts due on the Series 2016 Bonds. The District hereby requests the Board of Supervisors to annually levy a tax upon all taxable property in the District sufficient to redeem the Series 2016 Bonds, and to pay the principal, redemption premium, if any, and interest thereon as and when the same become due.

(b) *Principal.* The principal of the Series 2016 Bonds shall be payable in lawful money of the United States of America to the Owner thereof, upon the surrender thereof at the principal corporate trust office of the Paying Agent.

(c) *Interest; Record Date.* The interest on the Series 2016 Bonds shall be payable on each Interest Payment Date in lawful money of the United States of America to the Owner thereof as of the Record Date preceding such Interest Payment Date, such interest to be paid by check or draft mailed on such Interest Payment Date (if a business day, or on the next business day if the Interest Payment Date does not fall on a business day) to such Owner at such Owner's address as it appears on the Registration Books or at such address as the Owner may have filed with the Paying Agent for that purpose except that the payment shall be made by wire transfer of immediately available funds to any Owner of at least \$1,000,000 of outstanding Series 2016 Bonds who shall have requested in writing such method of payment of interest prior to the close of business on the Record Date immediately preceding any Interest Payment Date.

(d) *Interest and Sinking Fund.* Principal and interest due on the Series 2016 Bonds shall be paid from the interest and sinking fund of the District as provided in Section 15146 of the Education Code.

(e) *Obligation of the District.* No part of any fund or account of the County is pledged or obligated to the payment of the Series 2016 Bonds. The obligation for repayment of the Series 2016 Bonds is the sole obligation of the District.

(f) *Pledge of Taxes.* The District hereby pledges all revenues from the property taxes collected from the levy by the Board of Supervisors of the County for the payment of Bonds of the District and amounts on deposit in the interest and sinking fund of the District to the payment of the principal or redemption price of and interest on the Bonds. This pledge shall be valid and binding from the date hereof for the benefit of the owners of the Bonds and successors thereto. The property taxes and amounts held in the interest and sinking fund of the District shall be immediately subject to this pledge, and the pledge shall constitute a lien and security interest which shall immediately attach to the property taxes and amounts held in the interest and sinking fund of the District to secure the payment of the Bonds and shall be effective, binding, and enforceable against the District, its successors, creditors and all others irrespective of whether those parties have notice of the pledge and without the need of any physical delivery, recordation, filing, or further act. The pledge is an agreement between the District and the

owners of Bonds to provide security for the Bonds in addition to any statutory lien that may exist, and the Bonds secured by the pledge are or were issued to finance one or more of the projects specified in the applicable voter-approved measure.

(g) *Insurance.* The payment of principal of and interest on all or a portion of the Series 2016 Bonds may be secured by a municipal bond insurance policy as shall be described in the Bond Purchase Agreement. The Bond Purchase Agreement may provide that no municipal bond insurance policy shall be obtained. The Authorized Officers are each hereby authorized and directed to apply for municipal bond insurance for the Series 2016 Bonds and to obtain such insurance if the present value cost of such insurance is less than the present value of the estimated interest savings with respect to the Series 2016 Bonds. The Authorized Officers are each hereby authorized and directed, for and in the name and on behalf of the District, to execute and deliver a contract or contracts for such insurance if such contract is deemed by the Authorized Officer executing the same to be in the best interests of the District, such determination to be conclusively evidenced by such Authorized Officer's execution and delivery of such contract. If the Authorized Officers so deem and obtain municipal bond insurance, and such insurance is issued by a mutual insurance company, the Authorized Officers are each hereby authorized and directed to enter into any required mutual insurance agreement substantially in such insurer's standard form with such changes, insertions and omissions therein as the Authorized Officer executing the same may require or approve, such requirement or approval to be conclusively evidenced by the execution of such agreement by such Authorized Officer.

**Section 7. Redemption Provisions.** (a) *Optional Redemption.* The Series 2016 Bonds may be subject to redemption, at the option of the District, on the dates and terms as shall be designated in the Bond Purchase Agreement. The Bond Purchase Agreement may provide that the Series 2016 Bonds shall not be subject to optional redemption.

(b) *Selection.* If less than all of the Series 2016 Bonds, if any, are subject to such redemption and are called for redemption, such Series 2016 Bonds shall be redeemed in inverse order of maturities or as otherwise directed by the District (or as otherwise set forth in the Bond Purchase Agreement), and if less than all of the Series 2016 Bonds of any given maturity are called for redemption, the portions of such bonds of a given maturity to be redeemed shall be determined by lot (or as otherwise set forth in the Bond Purchase Agreement).

(c) *Mandatory Sinking Fund Redemption.* The Series 2016 Bonds, if any, which are designated in the Bond Purchase Agreement as term bonds shall also be subject to redemption prior to their stated maturity dates, without a redemption premium, in part by lot (or as otherwise set forth in the Bond Purchase Agreement), from mandatory sinking fund payments in the amounts and in accordance with the terms to be specified in the Bond Purchase Agreement. Unless otherwise provided in the Bond Purchase Agreement, the principal amount of each mandatory sinking fund payment of any maturity shall be reduced proportionately or as otherwise directed by the District by the amount of any Series 2016 Bonds of that maturity redeemed in accordance with subsection (a) of this Section prior to the mandatory sinking fund payment date. The Bond Purchase Agreement may provide that the Series 2016 Bonds shall not be subject to mandatory sinking fund redemption. The Auditor-Controller is hereby authorized

to create such sinking funds or accounts for the term Series 2016 Bonds as shall be necessary to accomplish the purposes of this Section.

(d) *Notice of Redemption.* Notice of any redemption of the Series 2016 Bonds shall be mailed by the Paying Agent, postage prepaid, not less than 30 nor more than 60 days prior to the redemption date (i) by first class mail to the County and the respective Owners thereof at the addresses appearing on the Registration Books, and (ii) as may be further required in accordance with the Continuing Disclosure Certificate.

Each notice of redemption shall state (i) the date of such notice; (ii) the name of the Series 2016 Bonds and the date of issue of the Series 2016 Bonds; (iii) the redemption date; (iv) the redemption price; (v) the series of Series 2016 Bonds and the dates of maturity or maturities of Series 2016 Bonds to be redeemed; (vi) if less than all of the Series 2016 Bonds of a series of any maturity are to be redeemed, the distinctive numbers of the Series 2016 Bonds of each maturity of such series to be redeemed; (vii) in the case of Series 2016 Bonds of a series redeemed in part only, the respective portions of the principal amount of the Series 2016 Bonds of each maturity of such series to be redeemed; (viii) the CUSIP number, if any, of each maturity of Series 2016 Bonds of a series to be redeemed; (ix) a statement that such Series 2016 Bonds must be surrendered by the Owners at the principal corporate trust office of the Paying Agent, or at such other place or places designated by the Paying Agent; (x) notice that further interest on such Series 2016 Bonds will not accrue after the designated redemption date; and (xi) in the case of a conditional notice, that such notice is conditioned upon certain circumstances and the manner of rescinding such conditional notice.

(e) *Effect of Notice.* A certificate of the Paying Agent that notice of redemption has been given to Owners as herein provided shall be conclusive as against all parties. Neither the failure to receive the notice of redemption as provided in this Section, nor any defect in such notice shall affect the sufficiency of the proceedings for the redemption of the Series 2016 Bonds or the cessation of interest on the date fixed for redemption.

When notice of redemption has been given substantially as provided for herein, and when the redemption price of the Series 2016 Bonds called for redemption is set aside for the purpose as described in subsection (g) of this Section, the Series 2016 Bonds designated for redemption shall become due and payable on the specified redemption date and interest shall cease to accrue thereon as of the redemption date, and upon presentation and surrender of such Series 2016 Bonds at the place specified in the notice of redemption, such Series 2016 Bonds shall be redeemed and paid at the redemption price thereof out of the money provided therefor. The Owners of such Series 2016 Bonds so called for redemption after such redemption date shall be entitled to payment thereof only from the interest and sinking fund or the trust fund established for such purpose. All Series 2016 Bonds redeemed shall be cancelled forthwith by the Paying Agent and shall not be reissued.

(f) *Right to Rescind Notice.* The District may rescind any optional redemption and notice thereof for any reason on any date prior to the date fixed for redemption by causing written notice of the rescission to be given to the owners of the Series 2016 Bonds so called for redemption. Any optional redemption and notice thereof shall be rescinded if for any reason on the date fixed for redemption moneys are not available in the interest and sinking fund or

otherwise held in trust for such purpose in an amount sufficient to pay in full on said date the principal of, interest, and any premium due on the Series 2016 Bonds called for redemption. Notice of rescission of redemption shall be given in the same manner in which notice of redemption was originally given. The actual receipt by the owner of any Series 2016 Bond of notice of such rescission shall not be a condition precedent to rescission, and failure to receive such notice or any defect in such notice shall not affect the validity of the rescission.

(g) *Funds for Redemption.* Prior to or on the redemption date of any Series 2016 Bonds there shall be available in the interest and sinking fund of the District, or held in trust for such purpose as provided by law, monies for the purpose and sufficient to redeem, at the redemption prices as in this Resolution provided, the Series 2016 Bonds designated in the notice of redemption. Such monies shall be applied on or after the redemption date solely for payment of principal of, interest and premium, if any, on the Series 2016 Bonds to be redeemed upon presentation and surrender of such Series 2016 Bonds, provided that all monies in the interest and sinking fund of the District shall be used for the purposes established and permitted by law. Any interest due on or prior to the redemption date shall be paid from the interest and sinking fund of the District, unless otherwise provided to be paid from such monies held in trust. If, after all of the Series 2016 Bonds have been redeemed and cancelled or paid and cancelled, there are monies remaining in the interest and sinking fund of the District or otherwise held in trust for the payment of redemption price of the Series 2016 Bonds, the monies shall be held in or returned or transferred to the interest and sinking fund of the District for payment of any outstanding bonds of the District payable from such fund; provided, however, that if the monies are part of the proceeds of bonds of the District, the monies shall be transferred to the fund created for the payment of principal of and interest on such bonds. If no such bonds of the District are at such time outstanding, the monies shall be transferred to the general fund of the District as provided and permitted by law.

(h) *Defeasance of Bonds.* If at any time the District shall pay or cause to be paid or there shall otherwise be paid to the Owners of any or all of the outstanding Series 2016 Bonds all or any part of the principal, interest and premium, if any, on the Series 2016 Bonds at the times and in the manner provided herein and in the Series 2016 Bonds, or as provided in the following paragraph, or as otherwise provided by law consistent herewith, then such Owners shall cease to be entitled to the obligation of the District as provided in Section 6 hereof, and such obligation and all agreements and covenants of the District and of the County to such Owners hereunder and under the Series 2016 Bonds shall thereupon be satisfied and discharged and shall terminate, except only that the District shall remain liable for payment of all principal, interest and premium, if any, represented by the Series 2016 Bonds, but only out of monies on deposit in the interest and sinking fund or otherwise held in trust for such payment; and provided further, however, that the provisions of subsection (i) of this Section shall apply in all events.

For purposes of this Section, the District may pay and discharge any or all of the Series 2016 Bonds by depositing in trust with the Paying Agent or an escrow agent, selected by the District, at or before maturity, money or non-callable direct obligations of the United States of America (including zero interest bearing State and Local Government Series) or other non-callable obligations the payment of the principal of and interest on which is guaranteed by a pledge of the full faith and credit of the United States of America, in an amount which will, together with the interest to accrue thereon and available monies then on deposit in the interest

and sinking fund of the District, be fully sufficient to pay and discharge the indebtedness on such Series 2016 Bonds (including all principal, interest and redemption premiums) at or before their respective maturity dates.

(i) *Unclaimed Monies.* Any money held in any fund created pursuant to this Resolution, or by the Paying Agent or an escrow agent in trust, for the payment of the principal or accreted value of, redemption premium, if any, or interest on the Series 2016 Bonds and remaining unclaimed for two years after the principal or accreted value of all of the Series 2016 Bonds has become due and payable (whether by maturity or upon prior redemption) shall be transferred to the interest and sinking fund of the District for payment of any outstanding bonds of the District payable from the fund; or, if no such bonds of the District are at such time outstanding, the monies shall be transferred to the general fund of the District as provided and permitted by law.

**Section 8. Paying Agent.** (a) *Appointment; Payment of Fees and Expenses.* This Board of Education does hereby consent to and confirm the appointment of The Bank of New York Mellon Trust Company, N.A., to act as the initial paying agent for the Series 2016 Bonds. All fees and expenses of the paying agent shall be the sole responsibility of the District, and to the extent not paid from the proceeds of sale of the Series 2016 Bonds, or from the interest and sinking fund of the District, insofar as permitted by law, including specifically by Section 15232 of the Education Code, such fees and expenses shall be paid by the District.

(b) *Resignation, Removal and Replacement of Paying Agent.* The Paying Agent initially appointed or any successor Paying Agent may resign from service as Paying Agent and may be removed at any time by the District as provided in the Paying Agent's service agreement. If at any time the Paying Agent shall resign or be removed, the District shall appoint a successor Paying Agent, which shall be any bank, trust company, national banking association or other financial institution doing business in and having a corporate trust office in California, with at least \$100,000,000 in net assets.

(c) *Principal Corporate Trust Office.* The initial Paying Agent, and any successor Paying Agent, shall designate each place or places where it will conduct the functions of transfer, registration, exchange, payment, and surrender of the Bonds, and any reference herein to the "principal corporate trust office" of the Paying Agent shall mean the office so designated for a particular purpose. If no office is so designated for a particular purpose, such functions shall be conducted at the office of The Bank of New York Mellon Trust Company, N.A. in Dallas, Texas, or the principal corporate trust office of any successor Paying Agent

(d) *Registration Books.* The Paying Agent shall keep or cause to be kept at its principal corporate trust office sufficient books for the registration and transfer of the Series 2016 Bonds, which shall at all times be open to inspection by the District and the County, and, upon presentation for such purpose, the Paying Agent shall, under such reasonable regulations as it may prescribe, register or transfer or cause to be registered or transferred on the Registration Books, Series 2016 Bonds as provided in Sections 9 and 10 hereof. The Paying Agent shall keep accurate records of all funds administered by it and of all Series 2016 Bonds paid and discharged by it. Such records shall be provided, upon reasonable request, to the District in a format mutually agreeable to the Paying Agent and the District.

**Section 9. Transfer Under Book-Entry System; Discontinuation of Book-Entry System.** (a) Unless otherwise specified in the Bond Purchase Agreement, DTC is hereby appointed depository for each series of the Series 2016 Bonds and the Series 2016 Bonds shall be issued in book-entry form only, and shall be initially registered in the name of "Cede & Co.," as nominee of DTC. One bond certificate shall be issued for each maturity of each series or subseries of the Series 2016 Bonds; provided, however, that if different CUSIP numbers are assigned to Series 2016 Bonds of a series or subseries maturing in a single year or, if Series 2016 Bonds of the same series or subseries maturing in a single year are issued with different interest rates, additional bond certificates shall be prepared for each such maturity. Registered ownership of such Series 2016 Bonds of each such maturity, or any portion thereof, may not thereafter be transferred except as provided in this Section or Section 10 hereof:

(i) To any successor of DTC, or its nominee, or to any substitute depository designated pursuant to clause (ii) of this Section (a "substitute depository"); provided, however that any successor of DTC, as nominee of DTC or substitute depository, shall be qualified under any applicable laws to provide the services proposed to be provided by it;

(ii) To any substitute depository not objected to by the District, upon (1) the resignation of DTC or its successor (or any substitute depository or its successor) from its functions as depository, or (2) a determination by the District to substitute another depository for DTC (or its successor) because DTC or its successor (or any substitute depository or its successor) is no longer able to carry out its functions as depository; provided, that any such substitute depository shall be qualified under any applicable laws to provide the services proposed to be provided by it; or

(iii) To any person as provided below, upon (1) the resignation of DTC or its successor (or substitute depository or its successor) from its functions as depository; provided that no substitute depository which is not objected to by the District can be obtained, or (2) a determination by the District that it is in the best interests of the District to remove DTC or its successor (or any substitute depository or its successor) from its functions as depository.

(b) In the case of any transfer pursuant to clause (i) or clause (ii) of subsection (a) of this Section, upon receipt of the outstanding Series 2016 Bonds by the Paying Agent, together with a written request of the District to the Paying Agent, a new Series 2016 Bond for each maturity shall be executed and delivered (in the aggregate principal amount of such Series 2016 Bonds then outstanding), registered in the name of such successor or such substitute depository, or their nominees, as the case may be, all as specified in such written request of the District. In the case of any transfer pursuant to clause (iii) of subsection (a) of this Section, upon receipt of the outstanding Series 2016 Bonds by the Paying Agent together with a written request of the District to the Paying Agent, new Series 2016 Bonds shall be executed and delivered in such denominations, numbered in the manner determined by the Paying Agent, and registered in the names of such persons, as are requested in such written request of the District, subject to the limitations of Section 5 hereof and the receipt of such a written request of the District, and thereafter, the Series 2016 Bonds shall be transferred pursuant to the provisions set forth in Section 10 hereof; provided, however, that the Paying Agent shall not be required to deliver such

new Series 2016 Bonds within a period of less than 60 days after the receipt of any such written request of the District.

(c) In the case of partial redemption or an advance refunding of the Series 2016 Bonds evidencing all or a portion of the principal amount then outstanding, DTC shall make an appropriate notation on the Series 2016 Bonds indicating the date and amounts of such reduction in principal.

(d) The District and the Paying Agent shall be entitled to treat the person in whose name any Series 2016 Bond is registered as the owner thereof, notwithstanding any notice to the contrary received by the District or the Paying Agent; and the District and the Paying Agent shall have no responsibility for transmitting payments to, communicating with, notifying, or otherwise dealing with any beneficial owners of the Series 2016 Bonds, and neither the District nor the Paying Agent shall have any responsibility or obligation, legal or otherwise, to the beneficial owners or to any other party, including DTC or its successor (or substitute depository or its successor), except for the Owner of any Series 2016 Bonds.

(e) So long as the outstanding Series 2016 Bonds are registered in the name of Cede & Co. or its registered assigns, the District and the Paying Agent shall cooperate with Cede & Co., as sole registered Owner, or its registered assigns in effecting payment of the principal of and interest on the Series 2016 Bonds by arranging for payment in such manner that funds for such payments are properly identified and are made immediately available on the date they are due.

**Section 10. Transfer and Exchange.** (a) *Transfer.* Following the termination or removal of DTC or successor depository pursuant to Section 9 hereof, any Series 2016 Bond may, in accordance with its terms, be transferred, upon the Registration Books, by the Owner thereof, in person or by the duly authorized attorney of such Owner, upon surrender of such Series 2016 Bond to the Paying Agent for cancellation, accompanied by delivery of a duly executed written instrument of transfer in a form approved by the Paying Agent.

Whenever any Series 2016 Bond or Series 2016 Bonds shall be surrendered for transfer, the designated District officials shall execute and the Paying Agent shall authenticate and deliver, as provided in Section 4 hereof, a new Series 2016 Bond or Series 2016 Bonds, of the same maturity, Interest Payment Date and interest rate or rates (for a like aggregate principal amount). The Paying Agent may require the payment by any Owner of Series 2016 Bonds requesting any such transfer of any tax or other governmental charge required to be paid with respect to such transfer.

No transfer of any Series 2016 Bond shall be required to be made by the Paying Agent (i) during the period established by the Paying Agent for selection of the Series 2016 Bonds for redemption, and (ii) after any Series 2016 Bond has been selected for redemption.

(b) *Exchange.* The Series 2016 Bonds may be exchanged for Series 2016 Bonds of other authorized denominations of the same maturity, Interest Payment Date and interest rate or rates, by the Owner thereof, in person or by the duly authorized attorney of such Owner, upon



surrender of such Series 2016 Bond to the Paying Agent for cancellation, accompanied by delivery of a duly executed request for exchange in a form approved by the Paying Agent.

Whenever any Series 2016 Bond or Series 2016 Bonds shall be surrendered for exchange, the designated District officials shall execute and the Paying Agent shall authenticate and deliver, as provided in Section 4 hereof, a new Series 2016 Bond or Series 2016 Bonds of the same maturity and interest payment mode and interest rate (for a like aggregate principal amount). The Paying Agent may require the payment by the Owner requesting such exchange of any tax or other governmental charge required to be paid with respect to such exchange.

No exchange of any Series 2016 Bonds shall be required to be made by the Paying Agent (i) during the period established by the Paying Agent for selection of the Series 2016 Bonds for redemption, and (ii) after any Series 2016 Bond has been selected for redemption.

**Section 11. Bond Purchase Agreement; Sale of Bonds.** The form of Bond Purchase Agreement, in substantially the form submitted to this meeting and made a part hereof as though set forth herein, is hereby approved, and the Authorized Officers are each hereby authorized and directed, for and in the name and on behalf of the District, to execute and deliver the Bond Purchase Agreement in substantially said form, with such changes, insertions and omissions therein as the Authorized Officer executing the same may require or approve, such approval to be conclusively evidenced by the execution and delivery thereof; provided, however, that (a) the true interest cost for Series 2016 Bonds shall not be in excess of 6.00%, (b) the interest rates on the Series 2016 Bonds shall not exceed 8.00% per annum, (c) the ratio of total debt service to principal of the Series 2016 Bonds shall not exceed four to one, (d) the Underwriter's discount for the sale of Series 2016 Bonds shall not exceed 1.00% of the principal amount of such Series 2016 Bonds (exclusive of any costs of issuance the Underwriter contracts to pay), and (e) the Series 2016 Bonds shall otherwise conform to the limitations specified herein. In connection with the negotiated sale of the Series 2016 Bonds, the Authorized Officers are, and each of them is, hereby authorized, and any one of the Authorized Officers is hereby directed, for and in the name of the District, to select one or more firms to serve as the Underwriter for the Series 2016 Bonds pursuant a proposal process, such selection to be conclusively evidenced by the execution of the Bond Purchase Agreement by an Authorized Officer.

The Bond Purchase Agreement shall recite the aggregate principal amount of the Series 2016 Bonds, and the date thereof, the maturity dates, principal amounts and annual rates of interest of each maturity thereof, the initial and semiannual Interest Payment Dates thereof, and the terms of optional, extraordinary and mandatory sinking fund redemption thereof, if any.

The Board of Education hereby finds and determines that the sale of the Series 2016 Bonds at negotiated sale as contemplated herein and by the Bond Purchase Agreement will provide more flexibility in the timing of the sale, and ability to implement the sale in a shorter time period, an increased ability to structure the Series 2016 Bonds to fit the needs of particular purchasers, and greater opportunity for the Underwriter to pre-market the Series 2016 Bonds to potential purchasers prior to the sale, all of which will contribute to the District's goal of achieving the lowest overall cost of funds. Estimates of the costs associated with the issuance of the Series 2016 Bonds, including any such costs which the Underwriter may agree to pay

pursuant to the Bond Purchase Agreement, are set forth on Exhibit B attached hereto and incorporated herein.

In accordance with subsection (h) of Section 15146 of the Education Code, to the extent not contracted to be paid by the Underwriter, the Authorized Officers are each hereby authorized to cause to be deposited in a costs of issuance account, which may be held by a bank, national banking association or trust company meeting the qualifications necessary to be a paying agent set forth in Section 8, as cost of issuance administrator, proceeds of sale of the Series 2016 Bonds (exclusive of any premium or accrued interest received) in an amount not exceeding 2.00% of the principal amount of the Series 2016 Bonds sold, as shall be set forth in the Bond Purchase Agreement, for the purposes of paying the costs associated with the issuance of the Series 2016 Bonds.

In accordance with subsections (i) and (j) of Section 15146 of the Education Code, the Authorized Officers are each hereby authorized to cause to be deposited in the interest and sinking fund of the District proceeds of sale of the Series 2016 Bonds (in addition to any premium or accrued interest received) to fund (i) an annual reserve permitted by Section 15250 of the Education Code, and/or (ii) capitalized interest in an amount not exceeding the interest scheduled to become due on the Series 2016 Bonds for a period of two years from the date of issuance of the Series 2016 Bonds, as shall be set forth in the Bond Purchase Agreement, if any such a deposit is deemed by the Authorized Officer executing the same to be in the best interests of the District.

**Section 12. Continuing Disclosure Certificate.** The Continuing Disclosure Certificate, in substantially the form submitted to this meeting and made a part hereof as though set forth herein, is hereby approved, and the Authorized Officers are each hereby authorized and directed, for and in the name and on behalf of the District, to execute and deliver the Continuing Disclosure Certificate in substantially said form, as is necessary to cause the requirements of Rule 15c2-12 to be satisfied, with such changes, insertions and omissions as the Authorized Officer executing the same may require or approve, such determination, requirement or approval to be conclusively evidenced by the execution of the Continuing Disclosure Certificate by such Authorized Officer.

**Section 13. Preliminary Official Statement.** The Preliminary Official Statement to be distributed in connection with the public offering of the Series 2016 Bonds, in substantially the form submitted to this meeting and made a part hereof as though set forth herein, with such changes, insertions and omissions as may be approved by an Authorized Officer, is hereby approved, and the use of such Preliminary Official Statement in connection with the offering and sale of the Series 2016 Bonds is hereby authorized and approved. The Authorized Officers are each hereby authorized to certify on behalf of the District that such Preliminary Official Statement is deemed final as of its date, within the meaning of Rule 15c2-12 (except for the omission of certain final pricing, rating and related information as permitted by Rule 15c2-12).

**Section 14. Official Statement.** The preparation and delivery of an Official Statement with respect to the Series 2016 Bonds, and its use by the Underwriter in connection with the offering and sale of the Series 2016 Bonds, is hereby authorized and approved. Such Official Statement shall be in substantially the form of the Preliminary Official Statement distributed in

connection with the public offering of the Series 2016 Bonds with such changes, insertions and omissions as may be approved by an Authorized Officer, such approval to be conclusively evidenced by the execution and delivery thereof. The Authorized Officers are each hereby authorized and directed, for and in the name of and on behalf of the District, to execute the final Official Statement with respect to the Series 2016 Bonds and any amendment or supplement thereto and thereupon to cause such final Official Statement and any such amendment or supplement to be delivered to the Underwriter.

**Section 15. Investment of Proceeds.** (a) All funds held in the interest and sinking fund of the District shall be invested at the discretion of the Treasurer of the County. In the absence of written request from the District, proceeds of the Series 2016 Bonds held in the building fund of the District shall be invested at the sole discretion of the Treasurer of the County pursuant to State law, including Government Code Section 53601 *et. seq.*, as the same may be amended or supplemented from time to time, and the investment policy of the County.

(b) To the extent permitted by law, at the written request of an Authorized Officer, each of whom is hereby expressly authorized to make such request, all or any portion of the building fund of the District may be invested on behalf of the District, in investment agreements, including guaranteed investment contracts, float contracts or other investment products (collectively, "Investment Agreements"), which comply with the requirements of each rating agency then rating the Series 2016 Bonds necessary in order to maintain the then-current rating on the Series 2016 Bonds. Pursuant to Section 5922 of the Government Code, the Board of Education hereby finds and determines that the Investment Agreements will reduce the amount and duration of interest rate risk with respect to amounts invested pursuant to the Investment Agreements and are designed to reduce the amount or duration of payment, rate, spread or similar risk or result in a lower cost of borrowing when used in combination with the Series 2016 Bonds or enhance the relationship between risk and return with respect to investments of proceeds of the Series 2016 Bonds and funds held to pay the Series 2016 Bonds.

**Section 16. Tax Covenants.** (a) The District shall not take any action, or fail to take any action, if such action or failure to take such action would adversely affect the exclusion from gross income of the interest payable on a Tax-Exempt series of Series 2016 Bonds under Section 103 of the Code. Without limiting the generality of the foregoing, the District hereby covenants that it will comply with the requirements of the Tax Certificate to be executed by the District on the date of issuance of each Tax-Exempt series of Series 2016 Bonds. The provisions of this subsection (a) shall survive payment in full or defeasance of the Series 2016 Bonds.

(b) In the event that at any time the District is of the opinion that for purposes of this Section it is necessary or helpful to restrict or limit the yield on the investment of any monies held by the Treasurer of the County on behalf of the District, in accordance with this Resolution or pursuant to law, the District shall so request of the Treasurer in writing, and the District shall make its best efforts to ensure that the Treasurer shall take such action as may be necessary in accordance with such instructions.

(c) Notwithstanding any provision of this Section, if the District shall provide to the Treasurer of the County an Opinion of Bond Counsel that any specified action required under this Section is no longer required or that some further or different action is required to maintain

the exclusion from federal income tax of interest on Series 2016 Bonds not issued as Taxable Bonds under Section 103 of the Code, the Treasurer may conclusively rely on such Opinion of Bond Counsel in complying with the requirements of this Section and of each Tax Certificate with respect to the Series 2016 Bonds not issued as Taxable Bonds, and the covenants hereunder shall be deemed to be modified to that extent.

**Section 17. Professional Services.** KNN Public Finance, LLC shall serve as financial advisor to the District for the Series 2016 Bonds. Orrick, Herrington & Sutcliffe LLP shall serve as bond counsel and disclosure counsel to the District for the Series 2016 Bonds.

**Section 18. Delegation of Authority.** The Authorized Officers are hereby authorized and directed, jointly and severally, to do any and all things which they may deem necessary or advisable in order to consummate the transactions herein authorized and otherwise to carry out, give effect to and comply with the terms and intent of this Resolution, including, without limitation negotiating the terms of the insurance policy, if any, referred to herein.

**Section 19. Approval of Actions.** All actions heretofore taken by the officers, employees and agents of the District with respect to the transactions set forth above are hereby approved, confirmed and ratified.

**Section 20. Filing with County.** The Superintendent, or such other officer or employee of the District as the Superintendent may designate, is hereby authorized and directed to report to the Auditor-Controller of the County the final terms of sale of the Series 2016 Bonds, and to file with the Auditor-Controller and with the Treasurer of the County a copy of each executed the Bond Purchase Agreement and this Resolution, and the schedule of amortization of the principal of and payment of interest on the Series 2016 Bonds, and to file with the Treasurer of the County a proposed schedule of draws on the building fund of the District, and this Resolution shall serve as the notice required to be given by Section 15140(c) of the Education Code and as the District's request to the Auditor-Controller of the County and the Board of Supervisors of the County to propose and adopt in each year a tax rate applicable to all taxable property of the District for payment of the Series 2016 Bonds, pursuant to law; and to the other officers of the County to levy and collect said taxes for the payment of the Series 2016 Bonds, to pay in a timely manner to the Paying Agent on behalf of the Owners of the Series 2016 Bonds the principal, interest, and premium, if any, due on the Series 2016 Bonds in each year, and to create in the County treasury to the credit of the District a building fund and an interest and sinking fund pursuant to Section 15146 of the Education Code.

**Section 21. Contract with Bondholders.** The provisions of this Resolution shall be a contract with each and every owner of Bonds and the duties of the District and of the Board of Education and the officers of the District shall be enforceable by any owner of Bonds by mandamus or other appropriate suit, action or proceeding in any court of competent jurisdiction.

**Section 22. Amendments.** This Resolution may be modified or amended without the consent of the Owners in order to cure ambiguities or provide clarification, provided that such modification or amendment does not materially adversely affect the rights of owners of Bonds. For any other purpose, this Resolution may be modified or amended only with the consent of the Owners of a majority of the aggregate principal amount of all Series 2016 Bonds then

outstanding; provided that any such modification or amendment to Section 6(f) or Section 21 shall require the consent of the owners of a majority of the aggregate principal amount of all Bonds then outstanding. No such modification or amendment shall extend the maturity of, reduce the interest rate or redemption premium on or principal amount of any Series 2016 Bond or reduce the percentage of consent required for amendment hereof without the express consent of all the owners so affected.

**Section 23. Indemnification of County.** The District shall indemnify and hold harmless, to the extent permitted by law, the County and its officers and employees (“Indemnified Parties”), against any and all losses, claims, damages or liabilities, joint or several, to which such Indemnified Parties may become subject because of action or inaction related to the adoption of any resolution by the Board of Supervisors of the County authorizing the District to issue and sell the Series 2016 Bonds without the further action of the Board of Supervisors pursuant to Sections 15140 and 15146 of the Education Code, as permitted by Section 53508.7 of the Government Code. The District shall also reimburse any such Indemnified Parties for any legal or other expenses incurred in connection with investigating or defending any such claims or actions.

**Section 24. Effective Date.** This Resolution shall take effect from and after its date of adoption.

**PASSED AND ADOPTED** this day, October 26, 2016.

  
\_\_\_\_\_  
President of the Board of Education of the  
Brentwood Union School District

ATTEST:  
  
\_\_\_\_\_  
Clerk of the Board of Education of the  
Brentwood Union School District

EXHIBIT A

FORM OF SERIES 2016 BOND

Number R-__	UNITED STATES OF AMERICA STATE OF CALIFORNIA COUNTY OF CONTRA COSTA	Amount \$ _____
----------------	---	--------------------

**BRENTWOOD UNION SCHOOL DISTRICT  
(CONTRA COSTA COUNTY, CALIFORNIA)  
GENERAL OBLIGATION BONDS, ELECTION OF 2016, SERIES 2016**

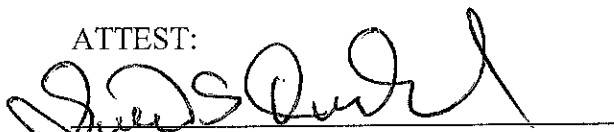
Maturity Date August 1, 20__	Interest Rate _____%	Dated as of _____, 20__	CUSIP No. _____
---------------------------------	-------------------------	----------------------------	--------------------

Registered Owner: CEDE & CO.

Principal Amount: \_\_\_\_\_ DOLLARS

Brentwood Union School District, Contra Costa County, State of California (the "District"), acknowledges itself obligated to and promises to pay to the Registered Owner identified above or registered assigns, on the Maturity Date set forth above or upon prior redemption hereof, the Principal Amount specified above in lawful money of the United States of America, and to pay interest thereon in like lawful money from the interest payment date next preceding the date of authentication of this Bond (unless this bond is authenticated after the close of business on a Record Date (as defined herein) and on or prior to the succeeding interest payment date, in which event it shall bear interest from such interest payment date, or unless this Bond is authenticated on or before \_\_\_\_\_ 15, 20\_\_, in which event it shall bear interest from the date hereof) at the Interest Rate per annum stated above, payable commencing on \_\_\_\_\_ 1, 20\_\_, and thereafter on February 1 and August 1 in each year, until payment of the Principal Amount. This Bond is issued pursuant to a Resolution adopted by the Board of Education of the District on October 26, 2016 (the "Resolution"). Capitalized undefined terms used herein have the meanings ascribed thereto in the Resolution.

The principal hereof is payable to the Registered Owner hereof upon the surrender hereof at the principal corporate trust office of The Bank of New York Mellon Trust Company, N.A., the paying agent/registrant and transfer agent of the District (the "Paying Agent"). The interest hereon is payable to the person whose name appears on the bond registration books of the Paying Agent as the Registered Owner hereof as of the close of business on the 15<sup>th</sup> day of the month preceding an interest payment date (the "Record Date"), whether or not such day is a business day, such interest to be paid by check or draft mailed to such Registered Owner at the owner's address as it appears on such registration books, or at such other address filed with the Paying Agent for that purpose. Upon written request, given no later than the Record Date immediately preceding an interest payment date, of the owner of bonds aggregating at least \$1,000,000 in principal amount, interest will be paid by wire transfer in immediately available funds to an account maintained in the United States as specified by the Registered Owner in such request. So

long as Cede & Co. or its registered assigns shall be the Registered Owner of this Bond, payment shall be made in immediately available funds as provided in the Resolution hereinafter described.

This Bond is one of a duly authorized issue of bonds of like tenor (except for such variations, if any, as may be required to designate varying series, numbers, denominations, interest rates, interest payment modes, maturities and redemption provisions), in the aggregate principal amount of \$ \_\_\_\_\_, and designated as "Brentwood Union School District (Contra Costa County, California) General Obligation Bonds, Election of 2016, Series 2016" (the "Bonds"). The Bonds were authorized by a vote of at least 55% percent of the voters voting at an election duly and legally called, held and conducted in the District on June 7, 2016. The Bonds are issued and sold by the Board of Education of the District pursuant to and in strict conformity with the provisions of the Constitution and laws of the State, and of the Resolution, and subject to the more particular terms specified in the Bond Purchase Agreement, dated \_\_\_\_\_, 2016 (the "Bond Purchase Agreement"), by and between the District and \_\_\_\_\_, as underwriter.

The Bonds are issuable as fully registered bonds without coupons in the denomination of \$5,000 principal amount or any integral multiple thereof, provided that no Bond shall have principal maturing on more than one principal maturity date. Subject to the limitations and conditions and upon payment of the charges, if any, as provided in the Resolution, Bonds may be exchanged for a like aggregate principal amount of Bonds of the same tenor, interest payment mode, and maturity of other authorized denominations.

This Bond is transferable by the Registered Owner hereof, in person or by attorney duly authorized in writing, at the principal corporate trust office of the Paying Agent, but only in the manner, subject to the limitations and upon payment of the charges provided in the Resolution, and upon surrender and cancellation of this Bond. Upon such transfer, a new Bond or Bonds of authorized denomination or denominations of the same tenor, interest payment mode, and same aggregate principal amount will be issued to the transferee in exchange herefor.

The District and the Paying Agent may treat the registered owner hereof as the absolute owner hereof for all purposes, and the District and the Paying Agent shall not be affected by any notice to the contrary.

[The Bonds are subject to optional and mandatory sinking fund redemption on the terms and subject to the conditions specified in the Resolution and the Bond Purchase Agreement. If this Bond is called for redemption and payment is duly provided therefor, interest shall cease to accrue hereon from and after the date fixed for redemption.]

The Board of Education of the District hereby certifies and declares that the total amount of indebtedness of the District, including the amount of this Bond, is within the limit provided by law; that all acts, conditions and things required by law to be done or performed precedent to and in the issuance of this Bond have been done and performed in strict conformity with the laws authorizing the issuance of this Bond; and that this Bond is in substantially the form prescribed by order of the Board of Education duly made and entered on its minutes. The Bonds represent an obligation payable out of the interest and sinking fund of the District, and the money for the

payment of principal of, premium, if any, and interest hereon, shall be raised by taxation upon the taxable property of the District.

Unless this Bond is presented by an authorized representative of The Depository Trust Company, a New York corporation ("DTC"), to the Paying Agent for registration of transfer, exchange, or payment, and any Bond issued is registered in the name of Cede & Co. or in such other name as is requested by an authorized representative of DTC (and any payment is made to Cede & Co. or to such other entity as is requested by an authorized representative of DTC), ANY TRANSFER, PLEDGE, OR OTHER USE HEREOF FOR VALUE OR OTHERWISE BY OR TO ANY PERSON IS WRONGFUL inasmuch as the Registered Owner hereof, Cede & Co., has an interest herein.

This Bond shall not be entitled to any benefit under the Resolution, or become valid or obligatory for any purpose, until the certificate of authentication and registration hereon endorsed shall have been signed by the Paying Agent.

**IN WITNESS WHEREOF**, the Board of Education of the Brentwood Union School District, County of Contra Costa, State of California, has caused this bond to be signed by its President and countersigned by the Clerk of said Board, as of the date set forth above.

---

President of the Board of Education of the  
Brentwood Union School District

Countersigned:

---

Clerk of the Board of Education of the  
Brentwood Union School District



**CERTIFICATE OF AUTHENTICATION AND REGISTRATION**

This is one of the Bonds described in the within-mentioned Resolution and authenticated and registered on \_\_\_\_\_.

**THE BANK OF NEW YORK MELLON  
TRUST COMPANY, N.A., AS PAYING  
AGENT**

By: \_\_\_\_\_  
Authorized Officer

## ASSIGNMENT

For value received the undersigned do(es) hereby sell, assign and transfer unto \_\_\_\_\_ the within-mentioned Bond and hereby irrevocably constitute(s) and appoint(s) \_\_\_\_\_ attorney, to transfer the same on the books of the Paying Agent with full power of substitution in the premises.

\_\_\_\_\_  
I.D. Number

\_\_\_\_\_  
Note: The signature(s) on this Assignment must correspond with the name(s) as written on the face of the within Bond in every particular, without alteration or enlargement or any change whatsoever.

Dated: \_\_\_\_\_

Signature Guarantee: \_\_\_\_\_  
Note: Signature must be guaranteed by an eligible guarantor institution.

## EXHIBIT B

### ESTIMATES OF COSTS OF ISSUANCE\*

A)	Underwriter's Discount	\$150,000.00
B)	Credit Enhancement	125,000.00
C)	Financial Advisor	61,000.00
D)	Bond Counsel	55,000.00
E)	Disclosure Counsel	27,500.00
F)	Special Counsel Opinion	30,000.00
G)	Other Expenses	70,000.00

\* A municipal bond insurance policy with respect to the Series 2016 Bonds will be obtained only if economically advantageous to the District as determined by an Authorized Officer of the District.

## CLERK'S CERTIFICATE

I, Scott Dudek, Clerk of the Board of Education of the Brentwood Union School District, County of Contra Costa, California, hereby certify that the foregoing is a full, true and correct copy of a resolution duly adopted at a regular meeting of the Board of Education of said District duly and regularly held at the regular meeting place thereof on October 26, 2016, and entered in the minutes thereof, of which meeting all of the members of the Board of Education had due notice and at which a quorum thereof was present, and that at said meeting the resolution was adopted by the following vote:

AYES: 5

NOES: 0

ABSTAIN: 0

ABSENT: 0

An agenda of the meeting was posted at least 72 hours before the meeting at 255 Guthrie Lane, Brentwood, California, a location freely accessible to members of the public, and a brief description of the resolution appeared on the agenda.

I further certify that I have carefully compared the same with the original minutes of said meeting on file and of record in my office; the foregoing resolution is a full, true and correct copy of the original resolution adopted at said meeting and entered in said minutes; and that said resolution has not been amended, modified or rescinded since the date of its adoption, and the same is now in full force and effect.

Dated: 10-26 2016

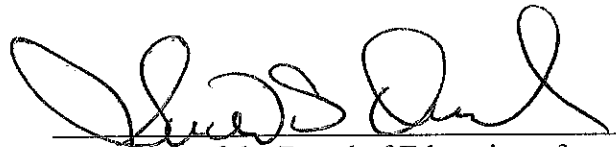
  
\_\_\_\_\_  
Clerk of the Board of Education of  
Brentwood Union School District