



RODEO-HERCULES FIRE PROTECTION DISTRICT
1680 REFUGIO VALLEY ROAD, HERCULES, CALIFORNIA 94547
(510) 799-4561 FAX: (510) 799-0395

ORDINANCE # 2019-01

FIRE CODE

ORDINANCE OF THE RODEO-HERCULES FIRE PROTECTION DISTRICT ADOPTING THE 2019 CALIFORNIA FIRE CODE WITH AMENDMENTS.

The Board of Directors of the Rodeo-Hercules Fire Protection District, ordains as follows:

SECTION 1. ADOPTION OF THE CALIFORNIA FIRE CODE.

The Rodeo-Hercules Fire Protection District hereby adopts the 2019 California Fire Code based on the 2018 International Fire Code published by the International Code Council, including Appendix Chapter 4, Section 435, Appendix A, Appendix B, Appendix C, Appendix D, Appendix E, Appendix F, Appendix G, Appendix H, Appendix I, Appendix J, Appendix L shall be applicable to any building exceeding 5 occupied stories in height or two stories below grade, Appendix N, and Appendix O as amended by the changes, additions and deletions set forth in this ordinance. The California Fire Code, with the changes, additions, and deletions set forth in this ordinance, is adopted by this reference as though fully set forth in this ordinance. As of the effective date of this ordinance, the provisions of the fire code are controlling and enforceable within the limits of each jurisdiction.

SECTION 2. AMENDMENTS TO THE CALIFORNIA FIRE CODE.

The 2019 California Fire Code is amended by the changes, additions and deletions set forth in this Section 2. Chapter and Section numbers used below are those of the 2019 California Fire Code.

Chapter 1. Administration.

Chapter 1 is adopted in its entirety except as amended below.

Section 101.1 is amended as follows:

101.1 Title. These regulations shall be known as the Fire Code of the Rodeo-Hercules Fire Protection District, hereinafter referred to as "*the code*"

Section 102.1 is amended to add item 5 to read:

102.1 Construction and design provisions. The construction and design provisions of this code shall apply to:

Where not otherwise limited by law, the provisions of this Code shall apply to vehicles, ships, boats, and mobile vehicles when fixed in a specific location within the boundaries of this

Section 103 is amended to add:

Section 103.5.1 Fire Suppression and Emergency Mitigation Fees. The Rodeo – Hercules Fire Protection District may charge fees that reasonably constitute the cost of suppression of any fire or emergency mitigation against a property owner or other responsible party when the fire or emergency is a result of that party's violation of any federal, state statute or local ordinance.

ORDINANCE NO. 2019-01

Pursuant to California Health and Safety Code sections 13910 through 13919, the District is permitted to charge fees to cover the costs of any service which the District provides. No fee can exceed the costs reasonably borne by the District in providing the service for which the fee is charged. In order to establish such a fee, the Board must adopt an ordinance establishing a schedule of fees. (RHFPD Ordinance 2017-2 Cost Recovery)

Section 103.5.1 Fire Prevention Personnel as Peace Officers. The Fire Chief and said Fire Chief designees shall have the powers of peace officers while engaging in the performance of their duties with respect to the prevention investigation and suppression of fires and the protection and prevention of life and property against the hazards of fire conflagration. In accordance with California Penal Code Chapter 4.5 (830.37(b))

The Fire Chief and duly authorized agents, may issue citations for violations of this ordinance in the same manner as a county or city is authorized to do so by Chapter 5C (commencing with Section 835.5) Title 3, Part 2, of the California Penal Code.

Section 105.6 is amended to read:

105.6 Required operational permits. The fire code official is authorized to issue operational permits for the operations set forth in Chapter 1, Sections 105.6.1 through 105.6.51.

Section 105.6 is amended by adding subsections 105.6.52 through 105.6.55, to read:

105.6.52 Christmas tree sales. A permit is required to use a property for the purpose of selling cut Christmas trees.

105.6.53 Firework aerial display. A permit is required to conduct a firework display regulated by California Code of Regulations, Title 19 and Chapter 33 of this code.

105.6.54 Model rockets. A permit is required to sell or launch model rockets pursuant to California Code of Regulations, Title 19, Division 1, Article 17.

105.6.55 Temporary water supply. A permit is required to use a temporary water supply for construction of residential projects or subdivisions pursuant to Sections 1412.2 and 1412.3.

Section 105.7 is amended to read:

105.7 Required construction permits. The fire code official is authorized to issue construction permits for the operations set forth in Chapter 1, Sections 105.7.1 through 105.7.25.

Section 105.7 is amended by adding sections 105.7.2a and 105.7.26 through 105.7.31 as follows:

105.7.2.a Battery system. A construction permit is required to operate stationary lead-acid battery systems having a liquid capacity of more than 50 gallons (189 L) pursuant to Section 608.

105.7.26 Access for fire apparatus. Plans shall be submitted and a permit is required to install, improve, modify, or remove public or private roadways, driveways, and bridges for which Fire District access is required by CFC. A permit is required to install a gate across a fire apparatus access road pursuant to Section 503.

ORDINANCE NO. 2019-01

105.7.27 Construction, alteration, or renovation of a building for which a building permit is required. Plans shall be submitted to the fire code official for all land developments or for the construction, alteration, or renovation of a building within the jurisdiction where a building permit is required.

105.7.28 Medical gas systems. A construction permit is required for the installation of or modification to a medical gas system pursuant to Section 3006.

105.7.29 Refrigeration equipment. A permit is required to install a mechanical refrigeration unit or system regulated by Chapter 6.

105.7.30 Land Development, Subdivisions. Plans shall be submitted to the fire code official for all land developments or improvements proposed within the jurisdiction that involve the subdivision of land.

105.7.31 Water supply for fire protection. Plans shall be submitted to the fire code official for the purpose of determining whether adequate water supplies, fire hydrants, and associated systems are provided for all facilities, buildings or portions of buildings either constructed or moved into the District pursuant to Section 507.

Section 109 is amended to read:

109 Board of Appeals established. In order to hear and decide appeals of orders, decisions or determinations made by the fire code official relative to the application and interpretation of this code, there is hereby created a board of appeals. The board of appeals is comprised of the Board of Directors. The fire code official shall be an ex officio member of said board but shall have no vote on any matter before the board. The board shall adopt rules of procedure for conducting its business, and shall render all decisions and findings in writing to the appellant with a duplicate copy to the fire code official.

Section 109.4 is amended in its entirety to read:

109.4 Violation penalties. Every person who violates any provision of this fire code is guilty of a misdemeanor. The imposition of one penalty for any violation shall not excuse the violation or permit it to continue; and all such persons shall be required to correct or remedy such violations or defects within a reasonable time; and when not otherwise specified, each ten (10) days that prohibited conditions are maintained shall constitute a separate offense. The application of the aforesaid penalty shall not be held to prevent the enforced removal of prohibited conditions. This section is a declaration of Health and Safety Code section 13871 and is not intended to create a different or separate penalty.

Section 111.5 is amended to read:

111.5 Failure to comply. Any person who continues any work after having been served with a stop work order is subject to citation, except any work that a person is directed by the fire code official to perform to remove a violation or unsafe condition.

Chapter 2. Definitions

Chapter 2 is adopted in its entirety except as amended below.

Section 202 is amended by adding the following definitions to read:

Administrator. Fire Chief.

ORDINANCE NO. 2019-01

All-weather driving surface. A roadway with a minimum surface finish of one layer of asphalt or concrete that is designed to carry the imposed weight loads of fire apparatus.

Board of Directors. The Rodeo-Hercules Fire Protection District Board of Directors.

Driveway. A private roadway that provides access to no more than two (2) single-family dwellings.

Fire Code Official. The Fire Code Official is the Fire Chief or his/her designee.

Firebreak. A continuous strip of land upon and from which all rubbish, weeds, grass or other growth that could be expected to burn has been abated or otherwise removed in order to prevent extension of fire from one area to another.

Fire trail. A graded firebreak of sufficient width, surface, and design to provide access for personnel and equipment to suppress and to assist in preventing a surface extension of fires.

Nuisance Fire Alarm. The activation of any fire protection or alarm system which results in the response of the Fire District and is caused by malfunction, improper maintenance, negligence, or misuse, of the system by an owner, occupant, employee, or agent, or any other activation not caused by excessive heat, smoke, fire, or similar activating event.

Response time. The elapsed time from receipt of call to the arrival of the first unit on scene.

Rural area. An area generally designated for agricultural or open space uses with parcels more than 10 acres (4.046873ha) in size.

Rural residential area. An area generally designated for single-family residential use with parcels between three (1.2140619ha) and 10 (4.046873ha) acres in size.

Running time. The calculated time difference between leaving the first-due station and arriving on the emergency scene.

Sprinkler Alarm & Supervisory System (SASS): A Dedicated Function Fire Alarm System located at the protected premise installed specifically to monitor sprinkler water-flow alarm, valve supervisory, and general trouble conditions where a Building Fire Alarm is not required.

Temporary fire department access road for construction. An approved temporary roadway for emergency vehicle use during construction of residential subdivision projects.

Temporary fire department access road for construction of one (1) residential (R3) unit. A temporary roadway for emergency vehicle use during construction of an individual residential (R3) structure where a fire department access road is required as part of the project.

Temporary water supply. Water stored for firefighting purposes in an approved aboveground tank during combustible construction.

Tree litter. Any limbs, bark, branches and/or leaves in contact with other vegetation or left to gather on the ground.

Weeds. All weeds growing upon streets or private property in the jurisdiction, including any of the following:

ORDINANCE NO. 2019-01

1. Weeds that bear seeds of a fluffy nature or are subject to flight.
2. Sagebrush, chaparral (including Chemise, Coyote Brush/Greasewood, Brooms, and Buckwheat), and any other brush or weeds that attain such large growth as to become, when dry, a fire menace to adjacent improved property.
3. Weeds that are otherwise noxious or dangerous.
4. Poison oak and poison sumac when the conditions of growth constitute a menace to public health.
5. Dry grass, brush, tree litter, litter, or other flammable materials that endanger the public safety by creating a fire hazard.

Rubbish. Waste matter, litter, trash, refuse, debris and dirt on streets, or private property within the jurisdiction, which may become, a fire hazard.

Streets. Includes alleys, parkways, driveways, sidewalks, and areas between sidewalks and curbs, highways, public right of ways, private road, trails, easements, and fire trails.

Person. Includes individuals, firms, partnerships, and corporations.

Defensible Space. The area within the perimeter of a parcel providing the key point of defense from an approaching wildland or escaping structure fire.

Priority Hazard Zone. An area where the threat from wildfire is severe due to proximity to open space, topography, degree of space, density of homes amount of vegetation (native and ornamental) and other conditions favorable to fast moving fires.

Reduced Fuel Zone. The area that extends from thirty feet (30') to one hundred feet (100') or more away from the structure or to the property line, whichever is closer to the structure.

Cost of Abatement. Includes all expenses incurred by the jurisdiction in its work of abatement undertaken and administrative costs pursuant to Section 319.5 of this Ordinance.

Chapter 3. General Safety Provisions.

Chapter 3 is adopted in its entirety except as amended below.

Section 304.1.2 is added to read:

304.1.2. Vegetation. (E) California Code of Regulations Title 19, Division 1, 3.07(b) Clearances.

Section 304.1.4 is added to read:

304.1.4 Clothes Dryers. Clothes dryers shall be frequently cleaned to maintain the lint trap, mechanical and heating components, vent duct and associated equipment free from accumulations of lint and combustible materials.

Section 308.1.4 Exception 1 is amended to read:

Exception 1. Residential Occupancies.

ORDINANCE NO. 2019-01

Section 321 is added to read:

321 Exterior Fire Hazard Control.

321.1.1 Jurisdictional Authority. The Board of Directors, as the supervising, legislative and executive authority of the jurisdiction, hereby delegates to the Board of Fire Commissioners of the jurisdiction all its powers, duties and rights to act pursuant to Part 5 (commencing with Section 14875), Division 12, of the Health and Safety Code, to clear or order the clearing of rubbish, litter or other flammable material where such flammable material endangers the public the safety by creating a fire hazard. Fire hazard abatement will be conducted in accordance with the provisions of said Part 5 and this ordinance. In the application of the provisions of said Part 5 to fire hazard abatement proceedings under this ordinance and the Fire Protection District Law of 1987, the terms "Board of Directors" or "Board," when used in Part 5, means the Board of Fire Commissioners of this jurisdiction under this section; and the officers designated in Health and Safety Code Section 14890 are the employees of the jurisdiction.

321.1.2 Contract for Services. The Board of Directors reserves and retains the power to award a contract for fire hazard abatement work when the employees of the jurisdiction are not used to perform the abatement work.

321.3 Weeds and Rubbish a Public Nuisance. The Board hereby declares that all weeds growing upon private property or streets in this jurisdiction and all rubbish on private property or streets in this jurisdiction are public nuisances. Such weed nuisance is seasonal and recurrent.

321.4 Abatement of Hazard.

321.4.1 Prohibition. No person who has any ownership or possessory interest in or control of parcel of land shall allow to exist thereon any hazardous rubbish, weeds, trees, or other vegetation that constitutes a fire hazard. Destruction by burning within this jurisdiction is unlawful unless the written permission of the fire chief is first obtained, and all other applicable permits are obtained from appropriate governing agencies or jurisdictions.

321.4.2 Specific Requirements. The District shall develop minimum abatement standards for land in residential, rural and/or rural residential, business, industrial areas, or land which is unused or vacant. Such standards may be modified periodically as circumstances dictate.

321.4.2.1 Clearance of Weeds from Streets. The Fire Code Official is authorized to cause areas within 10 feet (3048 mm) on each side of portions of streets that are improved, designed or ordinarily used for vehicular traffic to be cleared of flammable vegetation and other combustible growth. The Fire Code Official is authorized to enter upon private property to do so.

321.5 Abatement Procedures.

321.5.1 Abatement Order. The fire code official may order the abatement of the weeds and rubbish described in Sections 304.1.2 and 319.2. On making the order, the fire code official will mail a copy of a notice to the owners of the affected property as their names and addresses appear upon the last county equalized assessment roll, or as their names and addresses are known to the fire code official. As an alternative to mailing, the notice may be posted upon the affected property and published in the jurisdiction, not less than 15 days prior to the date of the abatement hearing. Copies of the notice will be headed with the words "Notice to Abate Weeds and Rubbish" in letters at least one inch high. The notice will be in substantially the following form:

ORDINANCE NO. 2019-01

NOTICE TO ABATE WEEDS AND RUBBISH

You are hereby notified that weeds and rubbish constitute a fire hazard on the following described property owned by you:

(Describe property by common street designation, by metes and bounds, Assessor's code area and parcel number, or by reference to attached map).

You must remove the weeds and rubbish within fifteen (15) days from the date of this notice. If you fail to do so, the (jurisdiction) Fire Protection District will remove it, and the cost of the abatement, including administrative costs, will be collected as property taxes and will be a lien on your property until paid.

You are further notified that the Board of Directors has declared that such weeds and rubbish constitute a public nuisance and that such weeds also constitute a seasonal and recurring nuisance.

You may appear before the Board of Directors of this jurisdiction on (time and date) at (place-room, street, address, and city) to show cause why this order should not be enforced.

(Signed): (Name of fire code official of name of jurisdiction)

321.5.2 Hearing Date. A date for hearing on the notice will be sent at least 15 days after the date of the notice. The date of the notice is the date on which the notice is placed in the United States mail or the date on which it is posted on the property. At the hearing, the property owner or his agent may appear to show cause why the order should not be enforced. For good cause shown, the Board of Directors may extend the time for compliance with the order or may rescind the order.

321.5.3 Contract Award. If the owner fails to comply with the order, the fire code official may have the weeds and rubbish abated either by employees of this jurisdiction or by contract. If a contract is awarded, it will be by public bid, awarded to the lowest responsible bidder. A contract may include work on more than one parcel. Concerning any contract previously awarded as provided in this subsection and that has been fully extended as provided in that contract, it may thereafter be extended on its same terms and conditions for a further period (not to exceed one year) by agreement of the Board of Directors and the involved contractor.

321.5.4 Abatement Report of Costs. The fire code official or his or her designee abating the nuisance will keep an account of the cost of abatement in front of or on each separate parcel of land and will render an itemized report in writing to the Board of Directors showing the cost of removing the weeds and rubbish on or in front of each separate lot or parcel of land, or both. Before the report is submitted to the Board of Directors, a copy of it will be posted for at least three days on or near the chamber door of the Board with a notice of the time and when the report will be submitted to the Board for confirmation. At the time fixed for receiving and considering the report, the Board of Directors will hear it and any objections of any of the property owners liable to be assessed for the work of abatement. Thereupon, the Board of Directors may make such modifications in the report as it deems necessary, after which the report will be confirmed. The amount of the cost, including administrative costs, of abating the nuisance in front of or upon the various parcels of the land mentioned in the report as confirmed will constitute special assessment against the respective parcels of land, and are a lien on the property for the amount of the respective assessments. Such lien attaches upon recordation, in the office of the County Recorder, of a certified copy of the Resolution of Confirmation.

ORDINANCE NO. 2019-01

321.5.5 Cost Assessments. Upon confirmation of the report of cost by the Board of Directors and the recordation of the Resolution of Confirmation, a copy of the report of cost will be sent to the County Auditor, who will enter the amount of the assessments against the parcels. Thereafter the amount of the assessments will be collected at the same time and in the same way as County taxes are collected. The owners are subject to the same penalties and the same procedure and sale in case of delinquency as provided for ordinary county taxes. All laws applicable to the levy, collection, and enforcement of county taxes are applicable to these assessment taxes.

321.6 Alternate Mitigation. In lieu of ordering abatement as provided in Section 319.5.1, the fire code official of this jurisdiction may order the preparation of firebreaks/fuelbreaks around parcels of property where combustible weeds, crops, or brush are present. In determining the proper width for firebreaks/fuelbreaks, the fire code official will consider the height of the growth, weather condition, topography, and the accessibility to the property for fire protection equipment. The procedure set forth in Section 319.5.1 for the abatement of weeds and rubbish shall apply to the preparation of firebreaks/fuelbreaks.

321.7 Subsurface Fires.

321.7.1 Peat Fire. It is the duty of each person, firm, corporation, or association not to permit a peat fire in or a fire involving combustible vegetable matters under the surface of the natural ground to remain upon the property. It is hereby declared that it is the duty of any person as herein defined to take all necessary precautions to extinguish any subsurface fire involving peat or vegetable material at the owner's own cost and expense.

321.7.2 Fire Suppression Costs. If there exists upon the lands or property of any person as herein defined a subsurface fire involving the burning or combustion of peat, vegetable matter or vegetation, and the owner or occupant thereof has not taken reasonable precautions within a reasonable time to extinguish or minimize such fire or combustion, this jurisdiction may, in addition to its regular duties to extinguish or minimize such fire or combustion, go upon the lands of any person as herein defined and extinguish such fire or combustion. Any costs incurred by the Fire District in fighting the fire and for the cost of proving rescue or emergency medical services shall be a charge against the property owner. The charge shall constitute a debt of the property owner and is collectable by the jurisdiction incurring those costs in the same manner as in the case of an obligation under a contract, express or implied. (See Health and Safety Code, §13009.)

Section 322 is added to Chapter 3 to read:

322 Automobile Wrecking Yards.

322.1 General. The operation of automobile wrecking yards shall be in accordance with this section.

322.2 Definitions.

Automobile Wrecking Yard. An area that stores or dismantles salvaged vehicles.

Automobile Dismantling. The operation of dismantling or removing parts from salvaged vehicles including engines or engine parts.

322.3 Requirements.

ORDINANCE NO. 2019-01

322.3.1 Permits. An operation permit is required for all automobile wrecking yards, automobile dismantling operations, and similar operations.

322.3.2 Fire Apparatus Access Roads. Fire apparatus access roads shall be constructed throughout the site in accordance with this code and shall be maintained clear of all vehicles and stored items.

322.3.3 Welding and cutting. Welding and cutting operations shall be conducted in an approved location, clear of all flammable liquids and combustible materials, including weeds, tires and all other debris.

322.3.4 Housekeeping. Combustible rubbish accumulated on site shall be collected and stored in approved containers, rooms or vaults of noncombustible materials. Combustible vegetation, cut or uncut, shall be removed when determined by the fire code official to be a fire hazard.

322.3.5 Fire Protection. Offices, storage buildings and vehicles used for site operations shall each be provided with at least one portable fire extinguisher with not less than a 4-A: 40-B-C rating. When required by the fire code official, additional fire extinguishers shall be provided.

322.3.6 Tire storage. Tires shall be stored in racks or in a manner as approved by the fire code official.

322.3.6.1 Distance from Water Supply. Tire storage shall be located on-site and no further than 500 feet from a fire hydrant or an approved water supply as determined by the fire code official.

322.3.7 Storage Piles. Storage piles shall be located a minimum of 20 feet from property lines and shall have an unobstructed access road on all sides of not less than 20 feet.

322.3.8 Burning operations. The burning of salvaged vehicles and salvaged or waste materials is prohibited.

322.3.9 Motor vehicle fluids. Motor vehicle fluid shall be drained from salvaged vehicles when such liquids are leaking onto the ground and prior to dismantling or removing engine/motor parts.

322.3.9.1 Mitigation of leaking fluids. Precautions shall be taken to prevent fluids from salvaged vehicles from leaking onto the ground. Supplies or equipment capable of mitigating leaks from fuel tanks, crankcases, brake systems and transmissions shall be kept available on site. Single-use plugs, diking and absorbent materials shall be disposed of as hazardous waste and removed from the site in a manner in accordance with federal, state and local requirements.

322.3.10 Fuel tanks. Fuel tanks of salvaged vehicles shall be emptied of all flammable (gasoline, diesel) fuels in an approved manner and stored in approved tanks.

322.3.10.1 Repair of vehicle fuel tanks. The repair of fuel tanks, including cutting, welding or drilling of any kind, is prohibited.

322.3.11 Lead acid batteries. Lead acid batteries shall be removed from all salvaged vehicles and stored in an approved manner in a location approved by the fire code official.

Chapter 4. Emergency Planning and Preparedness.

Chapter 4 is adopted in its entirety except as amended below.

Section 401.3.1 is amended by adding a new subsection 401.3.1.1 to read:

ORDINANCE NO. 2019-01

401.3.1.5 Nuisance Fire Alarm fee. A fee may be charged for false and/or nuisance fire alarms in accordance with a fee schedule adopted by the Board of Directors.

Chapter 5. Fire Service Features.

Chapter 5 is adopted in its entirety, except as amended below:

Section 503.1 is amended to add subsection 503.1.4 to read:

503.1.4 Access to Open Spaces. When existing access to open land or space, or to fire trail systems maintained for public or private use, is obstructed by new development of any kind, the developer shall provide an alternate means of access into the area that is sufficient to allow access for fire personnel and apparatus. The alternate means of access must be approved by the fire code official.

Section 503.2.1 is amended by adding the following exception:

Exception: A minimum sixteen-foot (16") wide driveway is acceptable for access to one or two single family dwellings.

Section 505 Premises Identification

Section 505.1 is amended and 505.3 is added to read

505.1 Illuminated address identification. Address numbers shall meet the specifications within 505.1 and be back lit to allow the addressing to be visible during low and no light conditions. Address sign shall be fitted to illuminate automatically during low to no light conditions.

505.3 Street names and addressing. Street names and addressing shall be submitted for review and approval to the fire code official, whose approval will not be unreasonably withheld. The purpose of the review is to verify that new street names and addressing will not duplicate existing street names and addressing.

Section 507.2 is amended by adding subsection 507.2.3, to read:

507.2.3 Suburban and rural water supply storage. Swimming pools and ponds shall not be considered water storage for the purposes of Section 507.1.

Chapter 6. Building Services and Systems.

Chapter 6 is adopted in its entirety, except as amended below.

Section 603.6 is amended by adding subsection 603.6.6, to read:

603.6.6 Sparks from chimneys. A chimney that is used with either a fireplace or heating appliances in which solid or liquid fuel is used shall be maintained with spark arresters that are required for incinerators pursuant to the California Mechanical Code.

Chapter 8. Interior Finish, Decorative Materials and Furnishings.

Chapter 8 is adopted in its entirety, except as amended below:

Section 806 is amended by adding subsections 806.1.4, 806.1.5 and 806.1.6, to read:

ORDINANCE NO. 2019-01

806.1.4 Flame retardant. Cut trees shall be treated by a California State Fire Marshal licensed fire retardant applicator. Trees shall be properly treated with an approved flame retardant.

806.1.5 Tags. Trees shall bear a tag stating date of placement in the public building, type of flame-retardant treatment used, name of the person who applied the flame retardant, the name of the person affixing the tag, a permit expiration date and the name of the designated individual making daily tests.

806.1.6 Daily tests. A designated individual shall test trees daily. The test shall include a check for dryness and adequate watering.

Chapter 9. Fire Protection Systems.

Chapter 9 is adopted in its entirety, except as amended below:

Section 901.6.2.2 is added to read:

901.6.2.2 Inspection Records. Records of all Inspections, testing and maintenance for all water based fire suppression systems shall be completed on the forms found in annex B of NFPA 25, California Edition.

Section 902 is amended to add:

SUBSTANTIAL REMODEL Remodel or renovation of any structure where the addition of new fire area to the structure exceeds fifty percent of the existing fire area shall be deemed a “substantial remodel.”

Section 903.2 is adopted in its entirety except as amended below:

903.2.1.1 Group A-1. An automatic sprinkler system shall be provided for Group A-1 occupancies where one of the following conditions exists:

1. The fire area exceeds 5000 square feet.
2. The fire area has an occupant load of 300 or more.
3. The fire area is located on a floor other than a level of exit discharge serving such occupancies.
4. The fire area contains a multi-theater complex.

903.2.1.3 Group A-3. An automatic sprinkler system shall be provided for Group A-3 occupancies where one of the following conditions exists:

1. The fire area exceeds 5,000 square feet.
2. The fire area has an occupant load of 300 or more.
3. The fire area is located on a floor other than a level of exit discharge serving such occupancies.
4. The structure exceeds 10,000 square feet, contains more than one fire area containing exhibition and display rooms, and is separated into two or more buildings by firewalls of less than four hour fire resistance rating without openings.

903.2.1.4 Group A-4. An automatic sprinkler system shall be provided for Group A-4 occupancies where one of the following conditions exists:

1. The fire area exceeds 5000 square feet
2. The fire area has an occupant load of 300 or more.
3. The fire area is located on a floor other than a level of exit discharge serving such occupancies.

903.2.2.1 Group B. An automatic sprinkler system shall be provided for Group B occupancies where the fire area exceeds 5,000 square feet.

ORDINANCE NO. 2019-01

903.2.3 Group E. Except as provided for in Section 903.2.3.1 for a new public school campus an automatic sprinkler system shall be provided for Group E occupancies as follows:

1. Throughout all Group E fire areas greater than 5000 square feet in area.
2. Throughout every portion of educational buildings below the lowest level of exit discharge serving that portion of the building.

Exception: An automatic sprinkler system is not required in any area below the lowest level of exit discharge serving that area where every classroom throughout the building has at least one exterior exit door at ground level.

3. In rooms or areas with special hazards such as laboratories, vocational shops and other such areas where hazardous materials in quantities not exceeding the maximum allowable quantity are used or stored.
4. Throughout any Group E structure greater than 10,000 square feet in area, which contains more than one fire area, and which is separated into two or more buildings by firewalls of less than four hour fire resistance rating without openings.

903.2.4 Group F-1. An automatic sprinkler system shall be provided throughout all buildings containing Group F-1 occupancy where one of the following conditions exists:

1. A Group F-1 fire area exceeds 5000 square feet.
2. A Group F-1 fire area is located more than three stories above grade plane.
3. The combined area of all Group F-1 fire areas on all floors, including any mezzanines, exceeds 10,000 square feet.

903.2.7 Group M. An automatic sprinkler system shall be provided throughout buildings containing Group M occupancy where one of the following conditions exists:

1. A Group M fire area exceeds 5000 square feet.
2. A Group M fire area is located more than three stories above grade plane.
3. The combined area of all Group M fire areas on all floors, including any mezzanines, exceeds 10000 square feet
4. A Group M occupancy is used for the display and sale of upholstered furniture.
5. The structure exceeds 10,000 square feet, contains more than one fire area containing Group M occupancy, and is separated into two or more buildings by firewalls of less than 4-hour fire-resistance rating.

903.2.8.2 Group R-3 Substantial Remodel. An automatic sprinkler system shall be provided throughout all existing Group R-3 dwellings where a substantial remodel occurs and the total fire area of the structure exceeds 3,600 square feet.

903.2.9 Group S-1. An automatic sprinkler system shall be provided throughout all buildings containing Group S-1 occupancy where one of the following conditions exists:

1. A Group S-1 fire area exceeds 5000 square feet
2. A Group S-1 fire area is located more than three stories above grade plane.
3. The combined area of all Group S-1 fire areas on all floors, including any mezzanines, exceeds 10000 square feet.

903.2.9.1 Repair garages. An automatic sprinkler system shall be provided throughout all buildings used as repair garages in accordance with Section 406 of the California Building Code, as shown:

1. Buildings having two or more stories above grade plane, including basements, with a fire area containing a repair garage exceeding 5000 square feet.

2. Buildings no more than one story above grade plane, with a fire area containing a repair garage exceeding 5000 square feet
3. Buildings with repair garages servicing vehicles parked in basements.

903.2.10 Group S-2 enclosed parking garages. An automatic sprinkler system shall be provided throughout buildings classified as enclosed parking garages in accordance with Section 406.4 of the California Building Code as follows:

1. Where the fire area of the enclosed parking garage exceeds 5000 square feet; or
2. Where the enclosed parking garage is located beneath other occupancy groups.

Section 903.3.5 is amended to add subsection 903.3.5.3 to read:

903.3.5.3 Non-permissible water supply storage. Swimming pools and ponds shall not be considered water storage for the purposes of Section 903.3.5.

Section 903.3.1.1.2 is added to read:

903.3.1.1.2 Undeclared Use. In buildings of undeclared use with floor to structure height greater than 14 feet (356 mm), the fire sprinkler system shall be designed to conform to Extra Hazard Group I design density. In buildings of undeclared use with floor to structure height less than 14 feet (356 mm), the fire sprinkler system shall be designed to conform to Ordinary Group II design density. Where a subsequent occupancy requires a system with greater capability, it shall be the responsibility of the owner and/or the occupant to upgrade the system.

Section 903.3.8 is amended to read:

903.3.8. Floor control valves. Individual floor control valves and water flow detection assemblies shall be provided for each floor in multi-floor buildings at an approved location.

Exception: Group R-3 and R-3.1 Occupancies

Section 903.4.2 is amended to read:

903.4.2 Alarms. One approved audible device shall be connected to every automatic sprinkler system at an approved location. Such sprinkler water-flow alarm devices shall be activated by water flow equivalent to the flow of a single sprinkler of the smallest orifice size installed in the system. Audible alarm devices shall be provided on the exterior of the building in an approved location. Where a fire alarm system is installed, actuation of the automatic sprinkler system shall actuate the building fire alarm system.

Section 903.6 is amended by adding subsections 903.6.1 and 903.6.2 to read:

903.6.1 Substantial Remodels. In an existing building, if any substantial remodel occurs where the total fire area of the building exceeds 5000 square feet, the entire building shall be protected by an automatic sprinkler system.

903.6.2 Change of occupancy classification. Any existing building that undergoes a change of occupancy classification into a higher hazard category shall comply with the requirements of Section 903.2 and Table 903.2. Relative hazard categories of occupancy groups shall be established based upon the Heights and Areas Hazard Categories of Table 912.5 of the current edition of the International Existing Building Code, as published by the International Code Council. The requirements of Section 903.2 and Table 903.2 shall not be required when a change of occupancy classification is made to an equal or lesser hazard category.

ORDINANCE NO. 2019-01

Group L occupancies shall be considered a relative hazard of 1 (highest hazard). R-3.x occupancies shall be considered a relative hazard of 4 (lowest hazard).

Section 907.5.4 is added to read:

907.5.4 Monitoring of other fire systems. In buildings equipped with a fire alarm system or sprinkler alarm and supervisory service (SASS) system, where other fire suppression or extinguishing systems are installed in the building (including but not limited to commercial kitchen suppression systems, pre-action fire suppression systems, dry chemical systems, and clean agent systems), these other suppression systems shall be monitored by the SASS dedicated function fire alarm system and transmitted as a specific signal to the Central Station.

Section 907.5.2.3.1 is amended to read:

907.5.2.3.1 Public and common areas. Visible alarm notification appliances shall be provided in public use areas and common use areas, including but not limited to:

1. Sanitary facilities including restrooms, bathrooms, shower rooms and locker rooms.
2. Corridors, hallways, aisles with shelving and/or fixtures obstructing the required light intensity for that area.
3. Music practice rooms.
4. Band rooms.
5. Gymnasiums.
6. Multipurpose rooms.
7. Occupational shops.
8. Occupied rooms where ambient noise impairs hearing of the fire alarm.
9. Lobbies
10. Meeting/Conference rooms.
11. Classrooms.
12. Medical exam rooms.
13. Open office areas.
14. Sales floor areas.
15. Break or lunch rooms
16. Copy or workrooms.
17. Computer server rooms exceeding 200 sq. ft.
18. File or Storage rooms exceeding 200 sq. ft.

Chapter 10. Means of Egress.

Chapter 10 is adopted in its entirety except as amended below.

Section 1027.6 is amended by adding a new subsection 1027.6.1 to read:

1027.6.1 Exit discharge surface. Exterior exit pathway surfaces shall be suitable for pedestrian use in inclement weather, and shall terminate at a public way as defined in the California Building Code.

Chapter 25. Fruit and Crop Ripening.

Chapter 25 is adopted in its entirety.

Chapter 26. Fumigation and Thermal Insecticidal Fogging.

Chapter 26 is adopted in its entirety.

Chapter 33. Fire Safety During Construction and Demolition.

ORDINANCE NO. 2019-01

Chapter 33 is adopted in its entirety.

Chapter 50. Hazardous Materials – General Provisions.

Chapter 50 is adopted in its entirety except as amended below:

Section 5001.5 is amended by adding subsection 5001.5.3 to read:

5001.5.3 Emergency response support information. Floor plans, material safety data sheets, Hazardous Materials Management Plans (HMMP), Hazardous Material Inventory Statements (HMIS), and other information may be required to be stored in cabinets located outside of facilities or buildings. Information may be required to be maintained in a specific electronic media format to facilitate computer aided dispatching.

Section 5003.9.1 is amended by adding subsection 5003.9.1.2 to read:

5003.9.1.2 Documentation. Evidence of compliance with provisions of this chapter as well as with state and federal hazardous material regulations shall be maintained on site and available for inspection by fire department personnel.

Chapter 56 Explosives and Fireworks.

Chapter 56 is adopted in its entirety except as amended below:

Section 5601 is amended to add Sections 5601.2, 5601.3, 5601.4 and 5601.5, to read:

5601.2 Fireworks. The possession, manufacture, storage, sale, handling and use of fireworks are prohibited. The possession, manufacture, storage, sale, handling and use of fireworks or pyrotechnic materials within the jurisdiction of the District are prohibited.

Exceptions:

1. Fireworks may be temporarily stored only if they are aerial or theatrical piece fireworks stored in conjunction with an approved and permitted aerial or set display.
2. Snap Caps and Party Poppers classified by the State Fire Marshal as pyrotechnic devices.

5601.2.1 Prohibited and Limited Acts. The storage of explosive materials is prohibited in any central business district and in all zoning districts except districts zoned for industrial or agricultural uses. In districts where the storage of explosive materials is permitted, the quantities of explosives and distances shall be in accordance with International Fire Code Sections 5601.8.1 and 5601.8.1.1.

5601.3 Rocketry. The storage, handling and use of model and high-power rockets shall comply with the requirements of the California Code of Regulations, Title 19, Chapter 6, Article 17 and, when applicable, NFPA 1122, NFPA 1125, and NFPA 1127.

5601.3.1 Ammonium nitrate. The storage and handling of ammonium nitrate shall comply with the requirements of NFPA 490.

Exception: The storage of ammonium nitrate in magazines with blasting agents shall comply with the requirements of NFPA 495.

5601.4 Residential uses. No person shall keep or store, nor shall any permit be issued to keep or store, any explosives, fireworks or pyrotechnic material at any place of habitation, or within 100 feet (30 480mm) thereof.

ORDINANCE NO. 2019-01

Exception: Storage of smokeless propellant, black powder, and small arms primers for personal use and not for resale.

5601.5 Sale and retail display. The possession, manufacture, storage, sale, handling and use of fireworks or pyrotechnic materials are prohibited.

Exception: Snap Caps and Party Poppers classified by the State Fire Marshal as pyrotechnic devices.

Section 5608 is amended by adding Sections 5608.2 and 5608.3 to read:

5608.2 Permit required. A permit is required to conduct an aerial display in accordance with California Code of Regulations, Title 19, Chapter 6. (See Chapter 1, Section 105.6.52.)

Exception: Snap Caps and Party Poppers classified by the State Fire Marshal as pyrotechnic devices.

5608.3 Financial responsibility. Before a permit is issued pursuant to Section 5608.2, the applicant shall file with the jurisdiction a corporate surety bond in the principal sum of \$1,000,000 or a public liability insurance policy for the same amount, for the purpose of the payment of all damages to persons or property which arise from, or are caused by, the conduct of any act authorized by the permit upon which any judicial judgment results. The fire code official is authorized to specify a greater or lesser amount when, in his or her opinion, conditions at the location of use indicate a greater or lesser amount is required. Government entities shall be exempt from this bond requirement.

Chapter 57.

Chapter 57 is adopted in its entirety except as amended below:

Section 5704.2.9.6.1 is amended to read:

5704.2.9.6.1 Locations where aboveground tanks are prohibited. The storage of Class I and II liquids in aboveground tanks outside of buildings is prohibited in all zoning districts except districts zoned for commercial, industrial, or agricultural uses.

Exception: Protected above-ground tanks for the purpose of emergency power generator installations in areas zoned commercial, industrial, agricultural, central business district, rural or rural residential, and for facilities on an individual basis consistent with the intent of this provision. Tank size shall not exceed 500 gallons (1892.706L) for Class I or II liquids, or 1,000 gallons (3785.412L) for Class III liquids.

Section 5706.2.4.4 is amended to read:

5706.2.4.4 Locations where aboveground tanks are prohibited. Storage of Class I and II liquids in aboveground tanks is prohibited in all zoning districts except district zoned for commercial, industrial, or agricultural use.

Chapter 55.

Chapter 55 is adopted in its entirety except as amended below:

Section 5501.3 is added to read:

5501.3 Limitation. The storage of flammable cryogenic fluids in stationary containers outside of buildings is prohibited in any area that is zoned for other than industrial use.

Exception: Liquid hydrogen fuel systems in compliance with section 5806.3 or 5806.4.

ORDINANCE NO. 2019-01

Chapter 61. Liquefied Petroleum Gases.

Chapter 61 is adopted in its entirety except as amended below:

Section 6103.2.1.7 is amended in its entirety to read:

6103.2.1.7 Use for food preparation. Individual portable L-P containers used, stored, or handled inside a building classified as a Group A or Group B occupancy for the purposes of cooking, food display, or a similar use, shall be limited in size to one-quart capacity and shall be of an approved type. The number of portable containers permitted will be at the discretion of the fire code official. LP-gas appliances used for food preparation shall be listed for such use in accordance with the International Fuel Gas Code, the International Mechanical Code, and NFPA 58.

Section 6104.2 is amended to read:

6104.2 Maximum capacity within established limits. The storage of liquefied petroleum gas is prohibited in any central business district and in all zoning districts except districts zoned for commercial, industrial, rural, or agricultural uses. The aggregate capacity of any one installation used for the storage of liquefied petroleum gas shall not exceed a water capacity of 2,000 gallons (7570 L).

Appendix B. Fire-Flow Requirements for Buildings.

Appendix B is adopted in its entirety except as amended below

Section B105.2 Exception 1 is amended to read:

Exception 1: A reduction in required fire-flow of 50 percent, as approved by the fire code official, when the building is provided with an approved automatic sprinkler system and installed in accordance with Section 903.3.1.1. The resulting fire-flow shall be not less than 1,500 gallons per minute (5678L/min) for the prescribed duration as specified in Table B105.1.

Appendix C. Fire Hydrant Locations and Distribution.

Appendix C is adopted in its entirety except as amended below

Table C105.1 footnote f and g are added to read:

- f. A fire hydrant shall be provided within 250 feet of a fire trail access point off a public or private street.
- g. For infill projects within existing single-family residential developments refer to Sec. 507.5.1

Appendix D. Fire Apparatus Access Roads

Appendix D is adopted in its entirety except as amended below

Section D102.1 is amended to read:

D102.1 Access and loading. Facilities, buildings or portions of buildings hereafter constructed shall be accessible to fire department apparatus by way of an *approved* fire apparatus access road with an asphalt, concrete or other approved *all-weather driving surface* capable of supporting the imposed load of fire apparatus weighing at least 74,000 pounds (33 566 kg) in accordance with Cal Trans Design Standard HS-20-44.

ORDINANCE NO. 2019-01

Exception: *Driveways* serving one or two single-family *dwelling*s may be constructed of an alternate surface material, providing the imposed weight load design minimums are met and the grade does not exceed 10 percent.

Section D103.1 is deleted in its entirety.

Section D103.2 is deleted in its entirety and replaced by the following, to read:

D103.2 Grade. Fire department access roadways having a grade of between 16 percent and 20 percent shall be designed to have a finished surface of grooved concrete sufficient to hold a 44,000-pound (19 958 kg) traction load. The grooves in the concrete surface shall be ½ inch (13 mm) wide by ½ inch (13 mm) deep and 1 ½ inch (38 mm) on center and set at a 30 to 45-degree angle across the width of the roadway surface. No grade shall exceed 20 percent, nor shall the cross slope exceed 8%, unless authorized in writing by the fire code official.

Section D103.2.1 is added to read:

D103.2.1 Angles of approach and departure. The angles of approach and departure for any means of access shall not exceed 10 percent at 10 feet of the grade break.

Section D103.3 is deleted in its entirety and replaced by the following, to read:

D103.3 Turning radius. Based on a minimum unobstructed width of 20 feet, a fire apparatus access roadway shall be capable of providing a minimum standard turning radius of 25 feet (7620 mm) inside and 45 feet (13 716 mm) outside.

Table D103.4 is amended to read:

Table D103.4
REQUIREMENTS FOR DEAD-END FIRE
APPARATUS ACCESS ROADS

LENGTH (feet)	MINIMUM WIDTH (feet)	TURNAROUNDS REQUIRED
0 – 150	20 ^a	None required
151 – 750	20 ^a	100-foot Hammerhead, 50-foot “Y”, 75-foot Shunt or 90-foot-diameter cul-de-sac in accordance with figure D103.1
Over 750		Special approval required

- a. A *driveway* with a minimum width of 16 feet is acceptable for access to no more than two single-family *dwelling*s.
- b. Any fire apparatus access roadway or *driveway* that is approved to be less than 20 feet wide and to exceed 750 feet in length shall have outsets or turnouts every 300 feet along the length of the road or driveway, or at locations approved by the fire code official. Each outset or turnout shall be of the following dimensions: an 8-foot wide turnout that extends at least 40 feet in length.

Figure D 103.1 is amended to read:

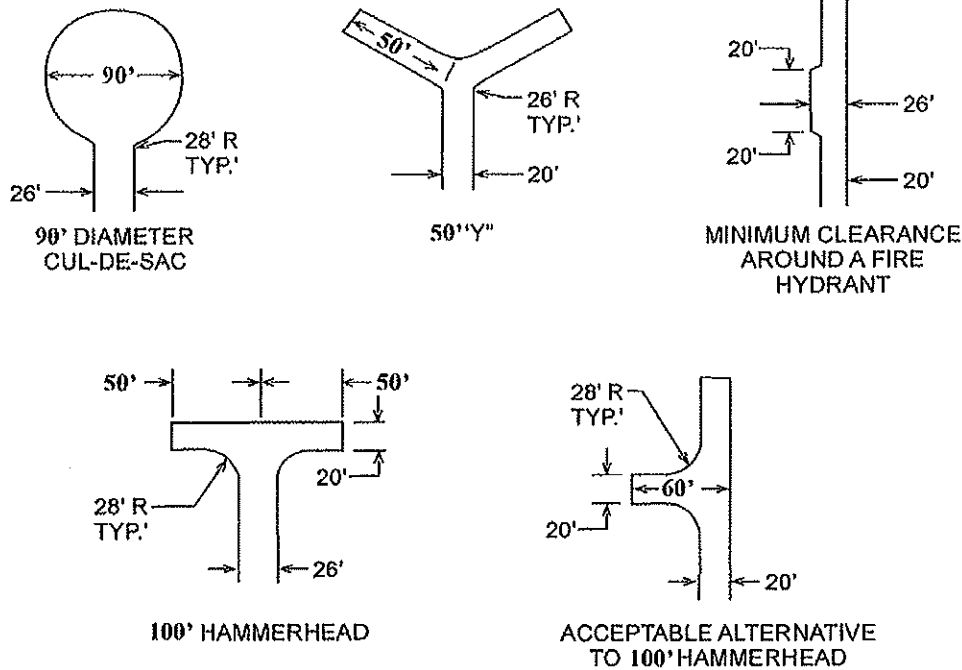

Figure D103.1
Dead-end Fire Apparatus Access Road Turnaround

Section D103.5 is amended by amending criteria 1 and adding criteria 8, to read:

1. The minimum clear width shall be 20 feet (6096mm.)
 Exception: For access to one or two single-family *dwelling*s, 16 feet clear width is acceptable.
8. All gates shall be installed and located a minimum of 30 feet off the street.

Section D105.3 is amended to read:

D105.3 Proximity to Building. At least one of the required access routes meeting this condition shall be located within a minimum of 15 feet (45772mm) and a maximum of 30 feet (9144mm) from the building, and shall be positioned parallel to one entire side of the building with the largest vertical dimension while allowing access to each floor of the building.

Section D106.1 is amended to read:

D106.1 Projects having more than 100 dwelling units. Multiple-family residential projects having more than 100 *dwelling units* shall be provided with two separate and *approved* fire apparatus access roads and shall meet the requirements of Section D104.3.

Exception: Deleted

SECTION 3. REPEAL OF FIRE CODE.

Ordinance No. 2013-1, adopting the 2013 California Fire Code with amendments, is hereby repealed.

SECTION 4. VALIDITY.

ORDINANCE NO. 2019-01

The Rodeo-Hercules Fire Protection District Board of Directors declares that if any section, paragraph, sentence or word of this ordinance or of the 2019 California Fire Code as adopted and amended herein is declared for any reason to be invalid, it is the intent of the Rodeo-Hercules Fire Protection District Board of Directors that it would have passed all other portions or provisions of this ordinance independent of the elimination here from any portion or provision as may be declared invalid.

SECTION 5. MORE RESTRICTIVE REQUIREMENTS.

If the city of Hercules or the County of Contra Costa adopts requirements more restrictive than those in this fire code, those requirements will apply only within the jurisdiction adopting those requirements.

SECTION 6. EFFECTIVE DATE.

This ordinance becomes effective 30 days after passage, and within 15 days of passage shall be published once with the names of directors voting for and against it in the Contra Costa Times, a newspaper published in this County.

Passed on October 23, 2019, by the following vote:

AYES: FRATHER, COVINGTON, GABRIEL, HILL, THORPE

NOES: 0

ABSENT: 0

ABSTAIN: 0

ATTEST:

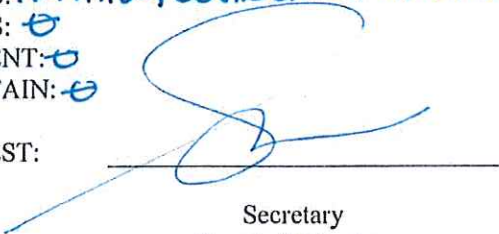

Secretary
Board of Directors



Chairman
Board of Directors